

# CLARKE®

## CWB1700P

Part Number: 4501510

### Assembly Instructions

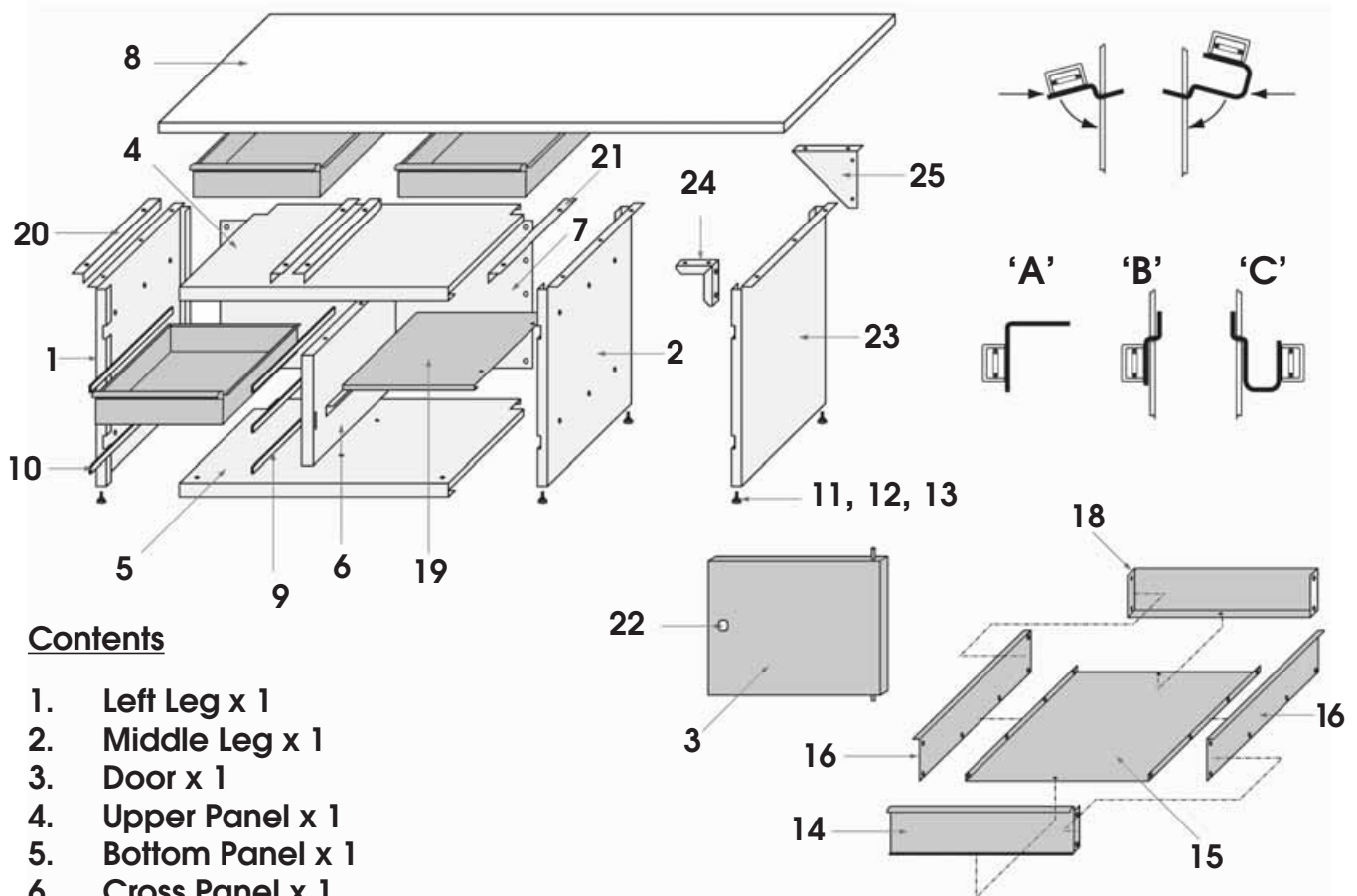

#### Contents

1. Left Leg x 1
2. Middle Leg x 1
3. Door x 1
4. Upper Panel x 1
5. Bottom Panel x 1
6. Cross Panel x 1
7. Back Panel x 1
8. Bench Top x 1
9. Drawer Runner (Type 'B') x 3
10. Drawer Runner (Type 'C') x 3
11. Foot x 6
12. Screw M8x40 x 6
13. Nut M8 x 6
14. Drawer Front x 5
15. Drawer Bottom x 5
16. Drawer Side x 10

18. Drawer Back x 5
19. Shelf x 1
20. Drawer Runner (Type 'A') L/H x 2
21. Drawer Runner (Type 'A') R/H x 2
22. Door Lock x 1
23. Right Leg x 1
24. Front Angle Bracket x 1
25. Rear Bracket x 1

Polythene bag containing nuts, screws and washers etc.

Please note that the details and specifications contained herein are correct at the time of going to print. However CLARKE International reserve the right to change specifications at any time without prior notice.

## SAFETY PRECAUTIONS

**ALWAYS** seek assistance when lifting heavy items.

**ALWAYS** keep children and animals away from tools and work area.

**ALWAYS** keep work area clean and free from oil spills etc.

## ASSEMBLY

Before attempting to assemble the work bench, carefully unpack/unwrap and lay out all components, check off against the list of contents on front page, notify your Clarke dealer ASAP of any shortages and/or damage.

### Tools required:

Cordless drill and drill bits (4mm and 5mm). Due to manufacturing tolerances, some holes may not line up accurately and may require opening up in order to fit securing screws.

1 x 12mm open ended spanner.

1 x Medium flat bladed screwdriver.

1 x 8mm ring or combination spanner.

1 x 7mm ring or combination spanner.

1 x Spirit Level.

### Optional:

Cordless screwdriver + screwdriver bits, 7mm and 8mm sockets, flexi drive and or nut spinners.

### Base Unit Assembly

*Hint - It may help with assembly to lay the legs and panels on their back edge until the bench is at a stage where it can be stood on its feet. Ensure some form of protection is laid down to prevent damage to the painted surfaces.*

**NOTE : Figures in brackets refer to item numbers in contents list on front page.**

1. Assemble feet (11, 12 & 13) and attach two to each leg. Screw in as far as possible. **DO NOT** tighten.
2. Attach the top panel (4) to the left leg (1) using M5x8 cheese head screws , nuts and lockwashers, **DO NOT** tighten at this stage.

**NOTE: Top panel has cut out in the front lip for the cross panel to fit into.**

3. Attach the bottom panel (5) with the left leg (1) and loosely secure with screws nuts and lockwashers.
4. Attach the middle leg (2) to the upper and lower panels and loosely secure with screws etc.
5. Attach the cross panel (6) between the upper and lower panels, before loosely securing with screws, ensure the cross panel is fitted with the shelf bracket facing the middle leg corresponding bracket and the cut out for the lock to the front of the unit.
6. Carefully turn the assembly onto its front, attach the back panel and loosely secure with screws etc.
7. Carefully stand the assembly on its feet.

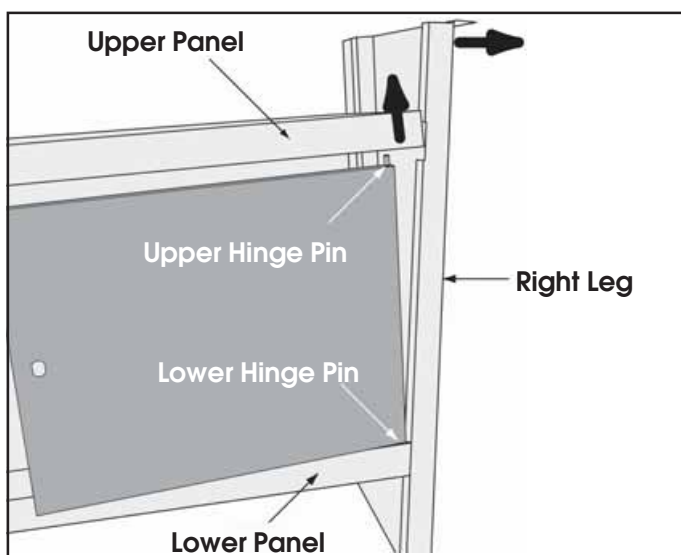

8. Remove the three screws etc securing the top panel (4) to the right leg (2), this is necessary to fit the door (3).
9. Fit the door (3) between the upper and lower panels as follows:  
Place flat washer (spacer) A6 on the bottom hinge pin, gently pull out the top of the right leg sufficiently to release the upper panel (see diag on left), insert the bottom hinge pin into the hole in the lower panel, raise the upper panel enough to allow the top hinge pin to pass under and locate into the corresponding hole. Lower the upper panel and reattach to the right leg and tighten screws etc.

10. To ensure the assembly is as square as possible before continuing, position the bench where it is to be sited. Place spirit level on the upper panel and adjust the feet until the unit is level in both directions, i.e. front to back and side to side, secure with locking nuts. Once satisfied the unit is as square as possible, proceed to tighten all screws and nuts, starting in the centre and working outwards until all are tight, DO NOT overtighten. Check the door is square and doesn't bind on the upper and/or lower panel.

11. Carefully lay the bench top upside down on the assembled bench, the arrow denotes the front of bench top, also the direction the drawers pull out.

*Hint - Using if available, a cordless screwdriver/drill, drive woodscrews L5 x 20 fully into all the pre-drilled holes, DO NOT overtighten. Remove afterwards.*

12. Loosely fit drawer runners (20 & 21 type 'A') with L shaped brackets to bench top.

**NOTE: Drawer runners are left and right handed and must be fitted in pairs so that the longest part of rail protrudes the bracket at the front of bench top.**

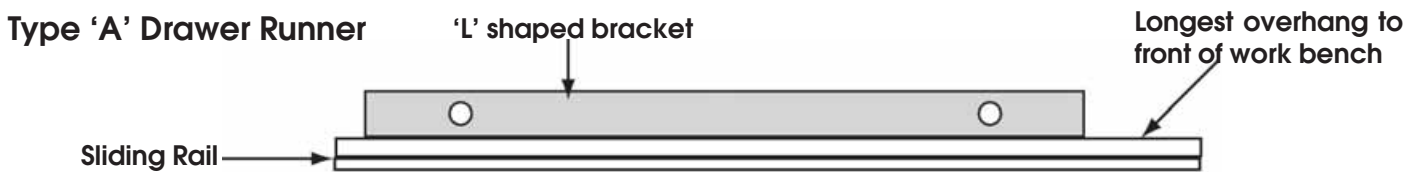

13. Loosely fit the angle brackets (24 & 25) at the points shown below. When fitting brackets, ensure the front 24 is fitted with the flush side facing outwards.

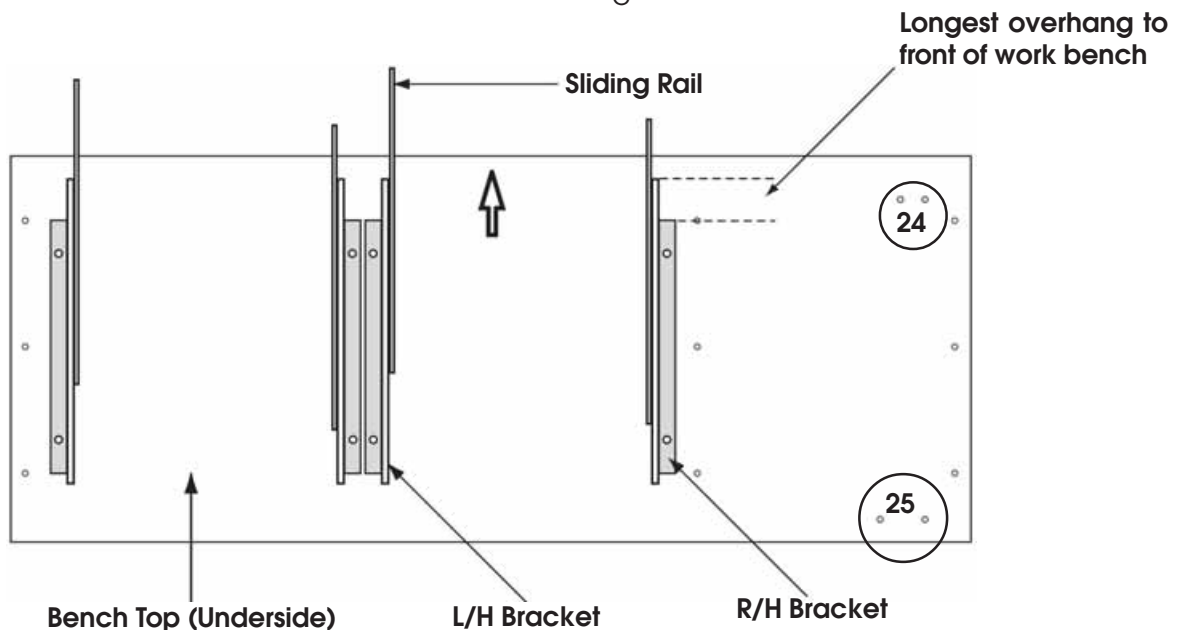

### Drawer Assembly

All drawers can be assembled at this stage and placed to one side for later.

**NOTE: Drawers are held together using M4x8 cheese head screws, nuts and lockwashers, all screwheads should be inside of assembled drawer.**

Refer to diagram on the front page when assembling.

1. Attach the front (14) and back (18) to the bottom (15) first, DO NOT tighten screws at this stage.
2. Attach the sides (16).
3. Once the drawer is fully assembled, proceed to tighten all screws and nuts, starting in the centre and working outwards, keeping the drawer as square as possible.

### Fitting Drawers

Fit two drawers to the prepared bench top as follows:

1. Pull the sliding rails out to the front of bench top as far as possible.
2. Fit drawer between rails.

3. Line up the hole in the rail with the hole at the front of the drawer and secure with countersunk screw, nut and lockwasher.

**NOTE: countersunk screw must be fitted from inside the rail with the nut and lockwasher inside the drawer.**

Once both drawers are fitted and secured, tighten all woodscrews securing drawer runners to the bench top.

### **Fitting Assembled Top to Base**

Carefully with assistance, turn the bench top assembly over, ensuring the drawers are between both legs, line up the securing holes in the tops of legs with the pre-drilled holes in the bench top and secure with woodscrews, DO NOT fully tighten until all six screws are fitted.

### **Fitting Right Hand Leg**

Fit the leg (**23**) in position under the R/H side of the bench top, line up the securing holes as with the other two legs and loosely secure with woodscrews.

Secure leg to angle brackets using M5x8 screws, nuts and lockwashers, DO NOT tighten until all screws are in place, tighten all screws including the woodscrews securing the brackets to the bench top. Finally wind the feet down sufficiently to support the R/H side of the work bench and secure with locking nut.

### **Fitting Drawers**

1. Fit the 3 drawer runners (**10** Type 'C') to the L/H leg. This is carried out simply by inserting the tongue's into the slots in the L/H leg as in diag, allow the runner to swing down in direction of arrow and come to rest against the leg, hence holding itself in position, (no fixings are required). Repeat for opposing runners (**9** Type 'B') to the left hand face of the cross panel.

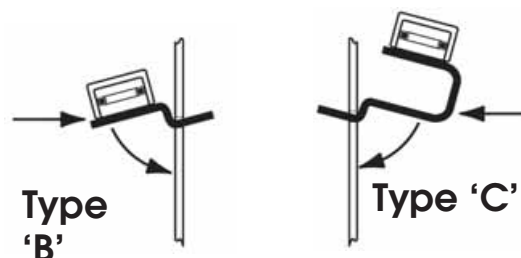

2. Attach the drawers to the runners as before (**Fitting Drawers**) starting at the bottom and working upwards.

### **Fitting Shelf**

The shelf has a right angle lip at the back with a 'U' shaped lip on the front. The shelf is fitted with the lips facing downwards with the largest cut out at the back and to the R/H side.

The shelf is simply fitted by inserting into cupboard at an angle, then just resting on the shelf brackets either side.

### **Fitting Door Lock**

**IMPORTANT Ensure the key remains in the lock until lock is fully fitted.**

Remove the locking lever securing screw and lock washer from the lock assembly, remove the lever and wavy washer noting which way round they are fitted for reassembly. Take care not to ensure the barrel does not fall out of the lock body.

Unscrew and remove the large securing nut and washer, insert the lock into the hole in the door, refit the washer and securing nut and tighten with spanner, DO NOT overtighten.

To determine the position of the locking lever, turn the key fully clockwise (locked position), fit the lever and wavy washer ensuring the lever is in the locked position, secure with screw and lock washer. Turn the key anticlockwise to determine the correct rotation for locking and unlocking i.e. anticlockwise = unlocked and clockwise = locked.

Before using the bench for the first time, we recommend the application of a propriety waterproof wood preservative to the bench top to prevent staining from oil spills etc.

**Your workbench is now ready for use.**

**PARTS & SERVICE TEL: 020 8988 7400**

**or e-mail as follows:**

**PARTS: [Parts@clarkeinternational.com](mailto:Parts@clarkeinternational.com)**

**SERVICE: [Service@clarkeinternational.com](mailto:Service@clarkeinternational.com)**