

Clarke[®] WOODWORKER

13" SCROLL SAW

Model No. CSS 300

Part No. 6470063

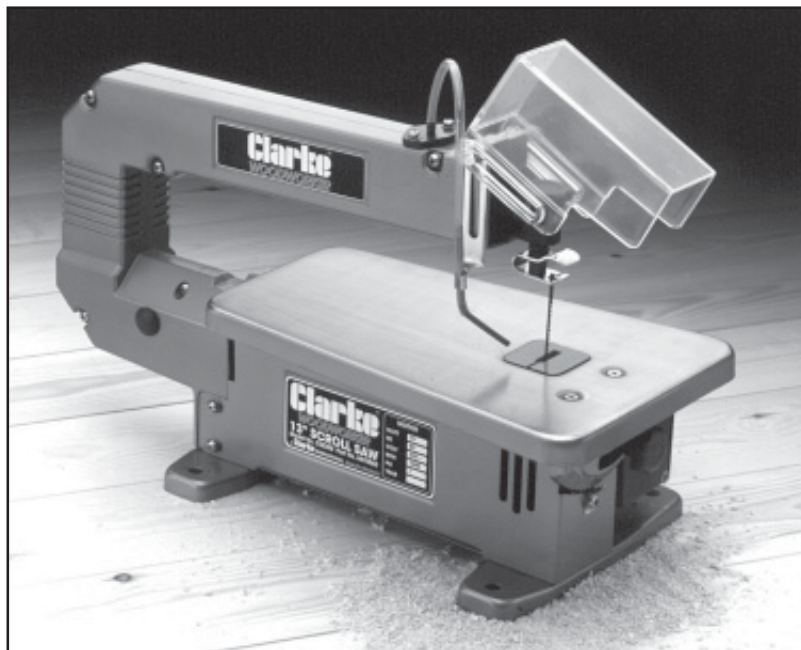

Operating and Maintenance Instructions

Thank you for purchasing this CLARKE 13" (330mm) Scroll Saw, designed for use by both professional and DIY enthusiast.

Before operating this machine, please read this leaflet thoroughly and follow the instructions carefully. In doing so you will ensure the safety of yourself and that of others around you, and you can look forward to the Scroll Saw giving you long and satisfactory service.

GUARANTEE

This CLARKE product is guaranteed against faulty manufacture for a period of 12 months from the date of purchase. Please keep your receipt as proof of purchase. This guarantee is invalid if the product is found to have been abused or tampered with in any way, or not used for the purpose for which it was intended.

Faulty goods should be returned to their place of purchase, no product can be returned to us without prior permission. This guarantee does not effect your statutory rights.

CONTENTS Page

Specifications	2
Safety Precautions General	3
Additional precautions for Scroll Saws	4
Electrical Connections	5
Assembly	5
Installation	6
Bevel Alignment	6
Blade renewal.....	7
Operating Characteristics	8
Cutting Intricate patterns	8
Parts list	9
Parts Diagram	10
Maintenance	11
Trouble Shooting	11

SPECIFICATIONS

Motor	
Voltage:	230V, 50Hz, 1 phase.
Power Rating:	75 Watts
Maximum thickness of cut:	40mm (1½")
Throat:	330mm (13")
Blade length:	125mm (5")
Strokes per minute:	1400
Stroke length:	8mm (5/16")
Table size:	305 x 190mm
Machine dimensions:	470x228x278mm
Table tilt:	0° - 45° left
Blade Type:	Pin
Gross / Net weight:	16 / 15kg

SAFETY PRECAUTIONS

GENERAL SAFETY RULES FOR OPERATING MACHINERY

WARNING:

As with all machinery, there are certain hazards involved with their operation and use. Exercising respect and caution will considerably lessen the risk of personal injury. However, if normal safety precautions are overlooked or ignored, injury to the operator may result.

1. READ and BECOME FAMILIAR with the entire operating manual. Learn the machines' applications and limitations as well as the specific potential hazards peculiar to it.
2. ALWAYS ENSURE THAT ADEQUATE LIGHTING is available. A minimum intensity of 300 lux should be provided. Ensure that lighting is placed so that you will not be working in your own shadow.
3. CHECK for DAMAGE. Before using the machine, any damaged part, such as a guard etc., should be checked to ensure that it will operate properly, and perform its intended function. Check for alignment of moving parts, breakage of parts, mountings, and any other condition that may affect the machines' operation. Any damage should be properly repaired or the part replaced. If in doubt, DO NOT USE the machine. Consult your local dealer.
4. DISCONNECT the MACHINE from the power supply before servicing and when changing accessories such as blades or working on the machine.
5. KEEP GUARDS in place and in working order.
6. ALWAYS WEAR SAFETY GOGGLES, manufactured to the latest European Safety Standards. Also use face or dust mask if cutting operation is dusty. Everyday eyeglasses do not have impact resistant lenses, they are NOT safety glasses.
7. KEEP WORK AREA CLEAN. Cluttered areas and benches invite accidents.
8. ALWAYS WEAR EAR PROTECTORS/DEFENDERS.
9. DON'T FORCE the Machine. It will do a better / safer job at the rate for which it was designed.
10. REMOVE ADJUSTING KEYS AND WRENCHES. Form the habit of checking to see that keys and adjusting wrenches are removed from the machine before switching on.
11. DRUGS, ALCOHOL, MEDICATION. Do not operate machine while under the influence of drugs, alcohol or any medication.
12. USE RECOMMENDED ACCESSORIES. The use of improper accessories could be hazardous.
13. NEVER LEAVE MACHINE RUNNING UNATTENDED. Turn power OFF. Do not leave machine until it comes to a complete stop.
14. EARTH ALL MACHINES. If the machine is equipped with three-pin plug, it should be plugged into a three-pin electrical socket. Never remove the earth pin.
15. AVOID DANGEROUS ENVIRONMENT. Don't use power machines in damp or wet locations or expose them to rain. Keep your work area well illuminated. DO NOT USE in explosive atmosphere (around paint, flammable liquids etc).
16. KEEP CHILDREN AWAY. All visitors should be kept a safe distance from the work area, especially whilst operating the unit.
17. MAINTAIN MACHINE IN TOP CONDITION. Keep tools sharp and clean for the best and safest performance. Follow maintenance instructions.
18. DON'T OVERREACH. Keep your proper footing and balance at all times. For best footing, wear rubber soled footwear. Keep floor clear of oil, scrap wood, etc.
19. WEAR PROPER APPAREL. Loose clothing or jewellery may get caught in moving parts. Wear protective hair covering to contain long hair.

20. MAKE WORKSHOP CHILDPROOF. Cover the saw adequately when not in use, to prevent children from damaging themselves by tampering with it.
21. NEVER STAND ON THE MACHINE. Serious injury could occur if the machine is tipped or if a cutting tool is accidentally contacted. Do not store materials above or near a machine, such that it is necessary to stand on the machine to reach them.
22. HANDLE WITH EXTREME CARE Whenever transporting or installing machinery, and always use a lifting tool.
23. AVOID ACCIDENTAL STARTING. Ensure the switch is OFF before plugging in to mains.
24. BE AWARE that accidents are caused by carelessness due to familiarity. ALWAYS concentrate on the job in hand, no matter how trivial it may seem.

ADDITIONAL SAFETY INSTRUCTIONS FOR SCROLL SAWS

1. Wear safety goggles as protection against flying wood chips and saw dust. In many cases, a full face shield is even better protection. A dust mask is also recommended to keep saw dust out of your lungs.
2. The scroll saw must be bolted securely to a stand or workbench. If the saw has a tendency to move during certain operations, bolt the stand or workbench to the floor.
3. A solid wood workbench is stronger and more stable than a workbench with a plywood table.
4. This scroll saw is for indoor use only.
5. Do not cut pieces of material which are too small to be held by hand.
6. Clear the work table of all objects except the workpiece (tools, scraps, rulers etc.) before turning the saw on.
7. Make sure the blades' teeth are pointing down, toward the table, and that the blade tension is correct.
8. When cutting a large piece of material, support it at the height of the table.
9. Do not feed the workpiece through the blade too fast. Feed only as fast as the blade will cut.
10. Keep your fingers away from the blade. Use a push stick as you near the end of the cut.
11. Take care when cutting a workpiece which is irregular in cross section. Moulding for example must lie flat, and not 'rock' on the table as it is being cut. A suitable support must be used.
12. Take care when 'backing off' a workpiece from the blade, as the blade may bind in the 'kerf'. In this event, switch OFF the machine and disconnect from the supply. Wedge open the kerf, and withdraw the workpiece.
13. Switch off the saw, and make sure the blade has come to a complete stop before clearing sawdust or off-cuts from the table.
14. Make sure there are no nails or foreign objects in the part of the workpiece to be sawn.
15. Be extra cautious with very large or small, or irregularly shaped workpieces.
16. Set up the machine and make all adjustments with the power OFF, and disconnected from the supply.
17. **DO NOT** operate the machine with the covers off. They must all be in place and securely fastened when performing any operation
18. Be sure to use the correct blade size and type.
19. Use ONLY approved replacement saw blades. Contact your local CLARKE dealer for advice. The use of inferior blades may increase the risk of injury.

ELECTRICAL CONNECTIONS

Connect the mains lead to a standard, 230 Volt (50Hz) electrical supply through an approved 13 amp BS 1363 plug, or a suitably fused isolator switch.

WARNING! THIS APPLIANCE MUST BE EARTHED

IMPORTANT: The wires in the mains lead are coloured in accordance with the following code:

Green & Yellow	-	Earth
Blue	-	Neutral
Brown	-	Live

As the colours of the flexible lead of this appliance may not correspond with the coloured markings identifying terminals in your plug proceed as follows:

Connect GREEN & YELLOW coloured cord to plug terminal marked with a letter "E" or Earth symbol \perp or coloured GREEN or GREEN & YELLOW.

Connect BROWN coloured cord to plug terminal marked with a letter "L" or coloured RED.

Connect BLUE coloured cord to plug terminal marked with a letter "N" or coloured BLACK.

If this appliance is fitted with a plug which is moulded onto the electric cable (i.e. non-rewirable) please note:

1. The plug must be thrown away if it is cut from the electric cable. There is a danger of electric shock if it is subsequently inserted into a socket outlet.
2. Never use the plug without the fuse cover fitted.
3. Should you wish to replace a detachable fuse carrier, ensure that the correct replacement is used (as indicated by marking or colour code).
4. Replacement fuse covers can be obtained from your local dealer or most electrical stockists.
5. The fuse in the plug must be replaced with one of the same rating (**5 amps**) and this replacement must be ASTA approved to BS1362.

PRINCIPAL PARTS OF THE SCROLL SAW

Fig. 1

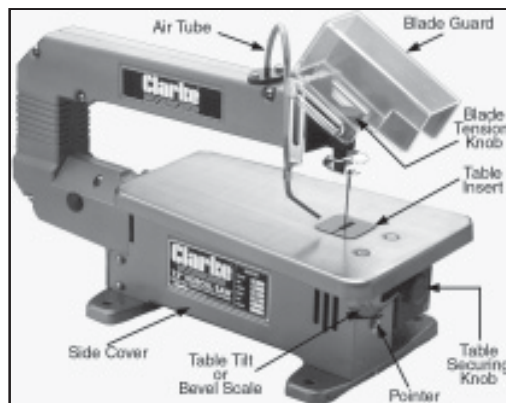

ASSEMBLY

Your Scroll Saw is fully assembled, except for the Blade Guard, and the Air tube. To attach these components, proceed as follows:

Line up the slotted hole in the blade guard and that in the air tube bracket, with the hole in the upper arm casing, and insert the bolt supplied. Note that the air tube bracket should lie between the blade guard and the upper arm, as shown in fig. 1. Thread on the washer and nut and tighten sufficiently so that the guard is firm but capable of movement. Do not over tighten.

INSTALLATION

Plan your installation. Ensure adequate space is available, with good lighting and ventilation, and an adequate electrical supply is close at hand.

1. MOUNTING YOUR SAW

Your Scroll Saw is provided with 4 mounting holes, and it is strongly recommended that you mount the machine on a solid surface. A pad between the saw and the workbench is further recommended. The best dimensions being - 24" x 12" x ½". Ensure you use flat washers between the bolt head and the mounting hole, and do not over tighten the bolts.

2. BLADE HOLDER ALIGNMENT

It is important that the blade holders are checked for alignment before use. Misaligned holders will cause the blade to wander, and reduce the blades' life expectancy.

To check the alignment,

- 2.1 Remove the side cover, by unscrewing the three retaining screws, (including the screw securing the table angle pointer), to give access to the lower holder.
- 2.2 Loosen the tension on the blade by turning the blade tension knob (see fig.1).
- 2.3 Remove the table insert, by squeezing the the two lugs, one either side of the slot, together, from beneath the table, whilst pushing upwards.
- 2.4 Disengage the blade pins from the upper blade holder, then the lower blade holder and pull the blade through the access hole in the table.
- 2.5 Slacken off the single hex. socket head screw securing lower blade holder, using the hex socket wrench supplied.
- 2.6 A metal strip is provided which should be inserted into the blade slots in both holders, thereby replacing the blade as shown in fig. 2.

With the steel strip in place and the holders therefore aligned, tighten the lower blade holder hex. socket head securing screw.

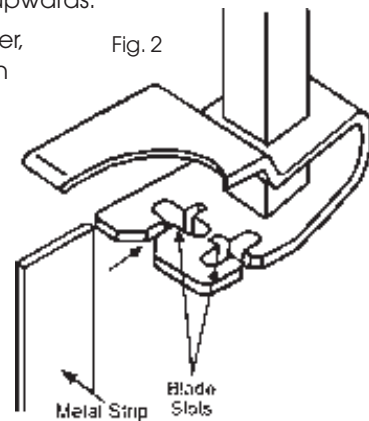

On completion, replace the side cover, table insert and blade by reversing the procedure above.

NOTE: If the blade tends to wander during use, re-check this adjustment as it may take one or two attempts to get it right. Also see page 8 - Straight Line Cutting, for other causes of blade wander.

3. TABLE ALIGNMENT (see fig. 3)

To ensure the table is correctly aligned, i.e. is at right angles to the blade, loosen the table securing knob, and level the table by bringing a small square up to the blade, as illustrated in fig.3. to ensure the table is at 90°.

When the table is perpendicular to the blade, tighten the table securing knob.

Finally, zero the pointer by loosening the securing screw, adjusting it so that it points to 0°, then retightening the securing screw.

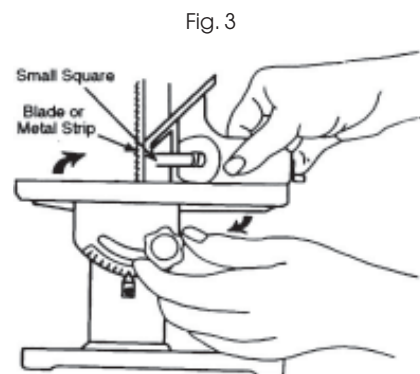

4. BLADE INSTALLATION / RENEWAL

1. Before installing or removing blades, turn OFF the saw and disconnect it from the supply. Remove the blade as described in 'Blade Holder Alignment', above.

NOTE:

Whilst the blade is out of the housings, look at the blade housings closely. You will observe that the blade slots and pin recesses are made so you can position the blade for cutting from the front, or from the side (see fig. 2). Cutting from the side is necessary when your workpiece is over 13" long.

IMPORTANT: Side cutting can only be performed when the table is set at 0°.

2. With the blade teeth pointing DOWNWARDS, slot the new blade into the lower housing so that the pins on the end of the blade, engage in the recess in the holder.
3. Hook the upper blade pins into the slots in the upper holder.
4. Apply tension the the blade by screwing the tension knob clockwise.

NOTES ON SAW BLADES **IMPORTANT: ALWAYS USE GOOD QUALITY BLADES**

BLADES BREAK FOR FIVE PRINCIPAL REASONS:

1. Too much tension or too little tension on the blade.
2. Overworking the blade by feeding the workpiece too fast.
3. Twisting or bending the blade by feeding the workpiece off-centre.
4. Over use - the blade has reached the end of its useful life.
5. Feeding too much material into the saw, - more than the maximum 40mm (1½") depth for which it was designed.

HOW TO DETERMINE THE RIGHT BLADE FOR THE JOB

This scroll saw accepts a wide variety of blade widths and thicknesses. The width of the blade, the thickness of the blade, and the number of teeth per inch (TPI) are determined by the type of material and size of the radius being cut. Here are several examples:

TPI	WIDTH	THICKNESS	MATERIAL
10	2.8mm 0.11"	0.5mm 0.020"	Medium curves on 1/4" to 1-1/2" wood, wallboard, hardboard.
15	2.8mm 0.11"	0.5mm 0.020"	Same as above, plus wood 1/8" to 1-1/4" thick
18	2.4mm 0.095"	0.25mm 0.011	Extra thin cuts on soft woods to 1/4" and parquetry

As a general rule, select the narrowest blades recommended for intricate curve cutting and widest blades for straight and large curve operations.

BEVEL CUTTING

When cutting bevels, set the table to your desired angle using the pointer as an indicator.

It should be remembered however that the bevel scale is a convenient indicator only, it is not guaranteed to be 100% accurate. Where absolute accuracy is required, always double check with a protractor before starting a cut.

SCROLL SAW OPERATING CHARACTERISTICS

The scroll saw's unique ability is cutting intricate curves which other saws cannot do. A scroll saw can also be used for straight line cutting such as cross cuts, ripping and bevels, The following is a list of points to remember when using a Scroll Saw.

1. The saw does not cut wood by itself. You feed the workpiece into the blade, letting the blade cut the wood as you move the piece ahead.
2. You must guide the wood into the blade SLOWLY, because the teeth are very small, and cut ONLY on the down stroke. If you push the wood into the blade too rapidly, you can easily break the blade.
3. Although the capacity of the saw accepts wood up to 40mm thick, better results are obtained with wood no more than 20mm thick. For wood thicker than 20mm, you must guide the wood into the blade **very slowly**, taking care not to bend or twist the blade.
4. The teeth on the blade will wear out sooner or later. The blade must therefore be replaced often to obtain the best cutting results. A blade will stay sharp for ½ hour to 2 hours of continuous running, depending on the material being cut.
5. Be aware that the blade has a tendency to follow the grain of the wood - the line of least resistance. You can compensate for this by watching the grain carefully and **guiding** the wood past the saw blade.
6. If you are not familiar with scroll saws, there will naturally be a learning period - a period to learn the saw itself, and a period to learn how the wood and saw work together. Expect some blade breakages, Scroll Saw blades are fairly fragile - not the same types of blade you find on a handsaw or circular saw.

STRAIGHT LINE CUTTING

A little practice will be necessary in order to create a straight line cut. This is due to the very design and nature of the machine itself. The saw blade is quite fragile and due to several different influences, will tend to wander off line. These influences include the following:

1. Blade tension. A slack blade will naturally wander off line.
2. Condition of the blade. A dull blade requires a greater effort to guide it through the work, thereby tending to force it off line.
3. Blade holders misaligned. The holders are secured with a single hex. socket head screw. Slacken the screw and adjust the holder so as to align correctly. The blade should be in line with the table, and not twisted.

CUTTING INTRICATE PATTERNS

One capability a scroll saw has that other saws do not, is cutting intricate patterns **inside** a workpiece. To do this, you should adopt the following procedure.

1. Drill a 1/4" hole in the middle of the workpiece, in a area which will not be a part of the finished object.
2. Switch off and unplug the machine from the supply.
3. Remove the blade from the machine.
4. Place the workpiece on the table, with the 1/4" hole over the access hole in the table.
5. Replace the blade, through the hole in the workpiece, (teeth downwards), and Re-tension the blade.
6. Plug the saw back in. Check to ensure that the workpiece is not touching the blade before switching ON.

When you are finished doing the work inside the workpiece, turn the saw off, unplug it, remove the blade, remove the workpiece, reinstall the blade, and plug the saw back in.

PARTS LIST

No.	Description	Part No.	No.	Description	Part No.
1.	Left Frame	HTSS300001	25.	Square Bolt	HTSS300025
2.	Screw	HTSS300002	26.	Spring	HTSS300026
3.	Rubber Block	HTSS300003	27.	Blade Holder Upper	HTSS300027
4.	Label	HTSS300004	28.	Screw	HTSS300028
5.	Copper Cover	HTSS300005	29.	Blade Holder Lower	HTSS300029
6.	Arm	HTSS300006	30.	Base	HTSS300030
7.	Screw	HTSS300007	32.	Bolt	HTSS300032
9.	Spring Washer	HTSS300009	33.	Bolt	HTSS300033
10.	Screw	HTSS300010	34.	Blade Guard	HTSS300034
11.	Connecting Screw	HTSS300011	35.	Washer	HTSS300035
12.	Roller	HTSS300012	36.	Nut	HTSS300036
13.	Roller Washer	HTSS300013	37.	Motor	HTSS300037
14.	Star Washer	HTSS300014	38.	Nut	HTSS300038
15.	Screw	HTSS300015	39.	Pointer	HTSS300039
16.	Protecting Plate	HTSS300016	40.	Screw	HTSS300040
17.	Warning Label	HTSS300017	41.	Hex. Screw	HTSS300041
18.	Right Frame	HTSS300018	42.	Table	HTSS300042
19.	Tension Knob	HTSS300019	43.	Screw	HTSS300043
20.	Washer	HTSS300020	44.	Bevel Scale Housing	HTSS300044
21.	Spring Washer	HTSS300021	45.	Table Securing Knob	HTSS300045
22.	Screw	HTSS300022	46.	Base Plate	HTSS300046
23.	Cam	HTSS300023	47.	Blade Insert	HTSS300047
24.	Screw	HTSS300024			

PARTS AND SERVICE



For Spare Parts and Servicing, please contact your nearest dealer, or
CLARKE International, on one of the following numbers.

PARTS - 0181 558 6696 SERVICE - 0181 556 4443

PARTS & SERVICE FAX - 0181 558 3622

Please note that the details and specifications contained herein, are correct at the time of going to print. However, CLARKE International reserve the right to change specifications at any time without prior notice.

PARTS DIAGRAM

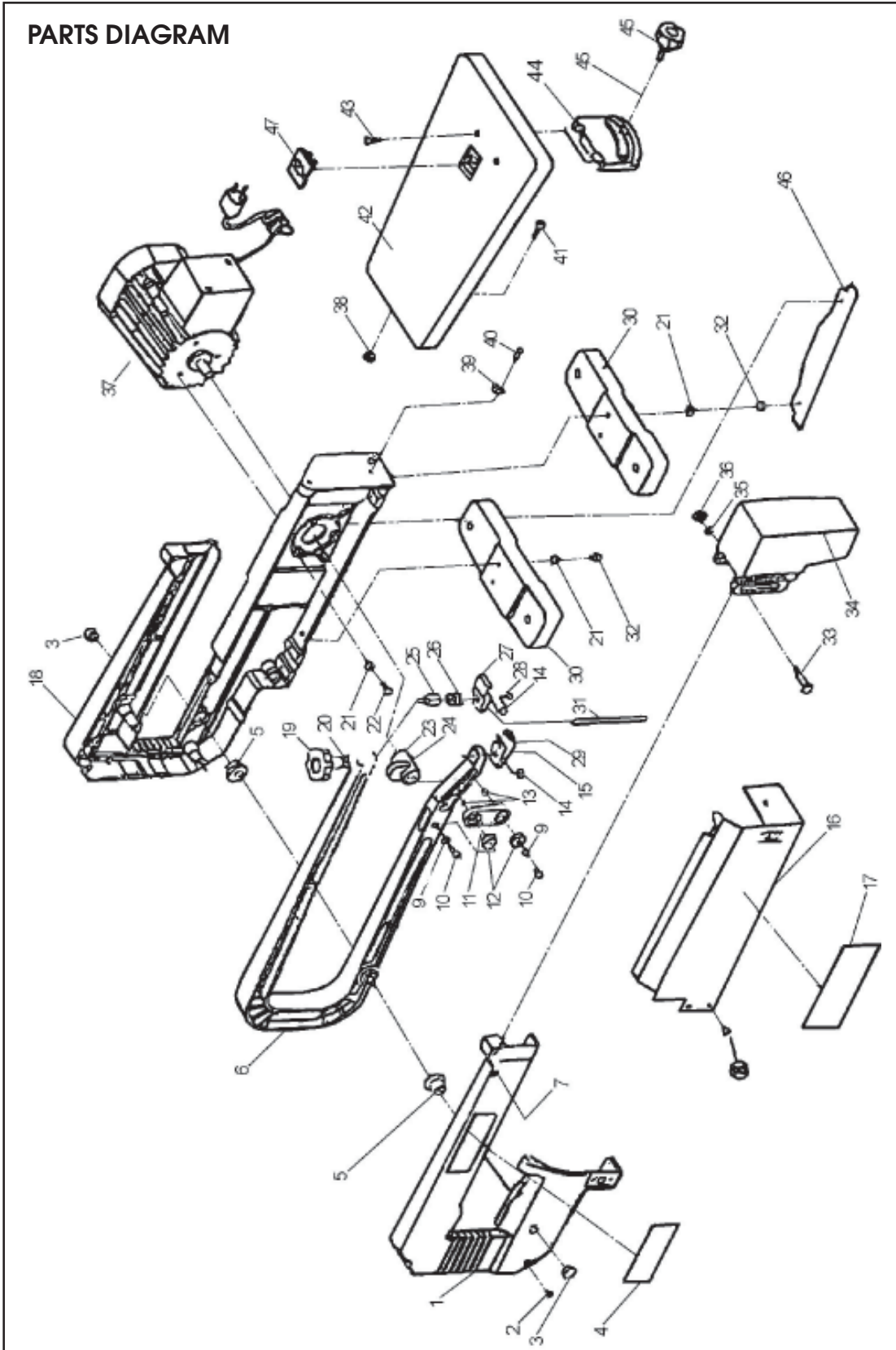

MAINTENANCE

- A. Apply a thin coat of paste wax on the work table from time to time. This will help the wood glide across the table more smoothly.
- B. The motor is permanently lubricated. Do not try to oil the motor bearings or service any internal parts of the motor. If the power cord is worn, frayed, cut or damaged, replace it. Do not try to patch it up with electrical tape this could lead to more trouble.

TROUBLESHOOTING

PROBLEM	PROBABLE CAUSES	SUGGESTED REMEDY
Breaking Blades.	<ol style="list-style-type: none"> 1. Incorrect tension. 2. Overworked (worn out) blade. 3. Wrong blade being used. 4. Twisting blade in wood. 	<ol style="list-style-type: none"> 1. Adjust blade tension. 2. Reduce feed rate or replace blade. 3. Use narrow blades for thin wood, wider blades for thicker wood. 4. Avoid side pressure on blade.
Motor Will Not Run.	<ol style="list-style-type: none"> 1. Defective cord, plug or outlet. 2. Defective motor. 	<ol style="list-style-type: none"> 1. Unplug saw, replace defective parts. 2. Repairs MUST be made by a qualified technician. Call Clarke Service dept. for advice.
Excessive Vibration (Some vibration is inevitable when the saw and motor are running)	<ol style="list-style-type: none"> 1. Improper mounting of saw. 2. Unsuitable mounting surface. 3. Loose table or table rubbing against motor. 4. Motor mount is loose. 	<ol style="list-style-type: none"> 1. See proper mounting instr (p5) 2. Replace plywood workbench surface with solid lumber surface. 3. Tighten table adjuster knob. 4. Tighten motor mount screws.
Blade Runout	<ol style="list-style-type: none"> 1. Blade holders not aligned. 2. Insufficient Blade tension 3. Dull Blade causing excessive force to be used at workpiece 	<ol style="list-style-type: none"> 1. Loosen screws holding blade holder to rocker arms. Adjust position of blade holders. Use metal strip to verify alignment. Retighten holder screws 2. Increase Blade tension 3. Renew Blade and correctly tension.