

# CLAMPKOR<sup>TM</sup>

## WOODWORKER



### 400mm (16") VARIABLE SPEED SCROLL SAW

Model No. CSS16V

Part No. 6460112



## Operating and Maintenance Instructions

# Clarke<sup>®</sup> INTERNATIONAL

This is an important document and should be retained

## DECLARATION OF CONFORMITY



We declare that this product complies with the following standards/directives:

- 98/37/EC
- 73/23/EEC

Description: **SCROLL SAW**

Model No: **CSS16V**

Serial (Batch) No: **See Product Date Plate**

Signed: 

**Clarke<sup>®</sup> INTERNATIONAL**  
Hemnal Street, Epping, Essex CM16 4LG

# Clarke<sup>™</sup>

## INTERNATIONAL

Thank you for purchasing this CLARKE 400mm (16") Scroll Saw, designed for DIY or hobby use.

Before operating this machine, please read this manual thoroughly and carefully follow the instructions given. In doing so you will ensure the safety of yourself and that of others around you, and you can look forward to the Scroll Saw giving you long and satisfactory service.

### GUARANTEE

This CLARKE product is guaranteed against faulty manufacture for a period of 12 months from the date of purchase. Please keep your receipt as proof of purchase.

This guarantee is invalid if the product is found to have been abused or tampered with in any way, or not used for the purpose for which it was intended.

Faulty goods should be returned to their place of purchase, no product can be returned to us without prior permission.

This guarantee does not effect your statutory rights.

### CONTENTS

#### Page

Safety Precautions General .....	4
Additional precautions for Scroll Saws .....	5
Electrical Connections .....	6
Principal Parts .....	7
Assembly .....	7
Installation .....	8
Blade Alignment .....	8
Bevel Alignment .....	9
Blade Renewal .....	9
Operation .....	9
Operating Characteristics .....	10
Straight Line Cutting .....	10
Cutting Intricate patterns .....	10
Saw Blade Notes .....	11
Maintenance .....	12
Trouble Shooting .....	12
Specifications .....	13
Accessories .....	13
Parts & Service Contacts .....	13
Parts list .....	14
Parts Diagram .....	15

## SAFETY PRECAUTIONS

### GENERAL SAFETY RULES FOR OPERATING MACHINERY

#### **WARNING:**

*As with all machinery, there are certain hazards involved with their operation and use. Exercising respect and caution will considerably lessen the risk of personal injury. However, if normal safety precautions are overlooked or ignored, personal injury to the operator may result.*

- ✓ **ALWAYS** read and become familiar with the entire operating manual. Learn the machines' applications and limitations as well as the specific potential hazards peculiar to it.
- ✓ **ALWAYS** ensure that adequate lighting is available. A minimum intensity of 300 lux should be provided. Ensure that lighting is placed so that you will not be working in your own shadow.
- ✓ **ALWAYS** check for damage. Before using the machine, any damaged part, such as a guard etc., should be checked to ensure that it will operate properly, and perform its intended function. Check for alignment of moving parts, breakage of parts, mountings, and any other condition that may affect the machines' operation. Any damage should be properly repaired or the part replaced. If in doubt, do not use the machine. Consult your local dealer.
- ✓ **ALWAYS** disconnect the machine from the power supply before servicing and when changing accessories such as blades, etc.
- ✓ **ALWAYS** keep guards in place and in working order.
- ✓ **ALWAYS** wear safety goggles, manufactured to the latest European safety standards and also use face or dust mask if cutting operation is dusty. Everyday eyeglasses do not have impact resistant lenses, they are not safety glasses.
- ✓ **ALWAYS** keep work area clean. Cluttered areas and benches invite accidents.
- ✓ **ALWAYS** remove adjusting keys and wrenches. Form the habit of checking to see that keys and adjusting wrenches are removed from the machine before switching on.
- ✓ **ALWAYS** use recommended accessories. The use of improper accessories could be hazardous.
- ✓ **ALWAYS** remove plug from the electrical outlet when adjusting, changing parts, or working on machine.
- ✓ **ALWAYS** earth all machines. If the machine is equipped with three-pin plug, it should be plugged into a three-pin electrical socket. **NEVER** remove the earth pin.
- ✓ **ALWAYS** avoid dangerous environment. Don't use power machines in damp or wet locations or expose them to rain. Keep your work area well illuminated. Do not use in explosive atmosphere (around paint, flammable liquids etc.).
- ✓ **ALWAYS** keep children away. All visitors should be kept a safe distance from the work area, especially whilst operating the unit.
- ✓ **ALWAYS** maintain machine in top condition. Keep tools sharp and clean for the best and safest performance. Follow maintenance instructions.
- ✓ **ALWAYS** wear proper apparel. Loose clothing or jewellery may get caught in moving parts. Wear protective hair covering to contain long hair.
- ✓ **ALWAYS** make workshop childproof. Cover the saw adequately when not in use, to prevent children from damaging themselves by tampering with it.
- ✓ **ALWAYS** handle with extreme care whenever transporting or installing machinery, and always use a lifting tool.
- ✓ **ALWAYS** avoid accidental starting. Ensure the switch is off before plugging in to mains.
- ✓ **ALWAYS** be aware that accidents are caused by carelessness due to familiarity. Always concentrate on the job in hand, no matter how trivial it may seem.

- ✗ NEVER force the machine. It will do a better and safer job at the rate for which it was designed.
- ✗ NEVER operate machine while under the influence of drugs, alcohol or any medication.
- ✗ NEVER leave machine running unattended. Turn power off. Do not leave machine until it comes to a complete stop.
- ✗ NEVER overreach. Keep your proper footing and balance at all times. For best footing, wear rubber soled footwear. Keep floor clear of oil, scrap wood, etc.
- ✗ NEVER stand on the machine. Serious injury could occur if the machine is tipped or if a cutting tool is accidentally contacted. Do not store materials above or near a machine, such that it is necessary to stand on the machine to reach them.

## ADDITIONAL SAFETY INSTRUCTIONS FOR SCROLL SAWS

1. Wear safety goggles as protection against flying wood chips and saw dust. In many cases, a full face shield is even better protection. A dust mask is also recommended to keep saw dust out of your lungs.
2. The scroll saw must be bolted securely to a stand or workbench. If the saw has a tendency to move during certain operations, bolt the stand or workbench to the floor.
3. A solid wood workbench is stronger and more stable than a workbench with a plywood table.
4. This scroll saw is for indoor use only.
5. Do not cut pieces of material which are too small to be held by hand.
6. Clear the work table of all objects except the workpiece (tools, scraps, rulers etc.) before turning the saw on.
7. Make sure the blades' teeth are pointing down, toward the table, and that the blade tension is correct.
8. When cutting a large piece of material, support it at the height of the table.
9. Do not feed the workpiece through the blade too fast. Feed only as fast as the blade will cut.
10. Keep your fingers away from the blade. Use a push stick as you near the end of the cut.
11. Take care when cutting a workpiece which is irregular in cross section. Moulding for example must lie flat, and not 'rock' on the table as it is being cut. A suitable support must be used.
12. Take care when 'backing off' a workpiece from the blade, as the blade may bind in the 'kerf'. In this event, switch OFF the machine and disconnect from the supply. Wedge open the kerf, and withdraw the workpiece.
13. Switch off the saw, and make sure the blade has come to a complete stop before clearing sawdust or off-cuts from the table.
14. Make sure there are no nails or foreign objects in the part of the workpiece to be sawn.
15. Be extra cautious with very large or small, or irregularly shaped workpieces.
16. Set up the machine and make all adjustments with the power OFF, and disconnected from the supply.
17. **DO NOT** operate the machine with the covers off. They must all be in place and securely fastened when performing any operation
18. Be sure to use the correct blade size and type.
19. Use ONLY approved replacement saw blades. Contact your local CLARKE dealer for advice. The use of inferior blades may increase the risk of injury.

## ELECTRICAL CONNECTIONS

Connect the mains lead to a standard, 230 Volt (50Hz) electrical supply through an approved 13 amp BS 1363 plug, or a suitably fused isolator switch.



**WARNING! THIS APPLIANCE MUST BE EARTHED**

IMPORTANT: The wires in the mains lead are coloured in accordance with the following code:

Green & Yellow - Earth  
Blue - Neutral  
Brown - Live

As the colours of the flexible lead of this appliance may not correspond with the coloured markings identifying terminals in your plug proceed as follows:

- Connect GREEN & YELLOW coloured cord to plug terminal marked with a letter "E" or Earth symbol "⏏" or coloured GREEN or GREEN & YELLOW.
- Connect BROWN coloured cord to plug terminal marked with a letter "L" or coloured RED.
- Connect BLUE coloured cord to plug terminal marked with a letter "N" or coloured BLACK.

If this appliance is fitted with a plug which is moulded onto the electric cable (i.e. non-rewirable) please note:

1. The plug must be thrown away if it is cut from the electric cable. There is a danger of electric shock if it is subsequently inserted into a socket outlet.
2. Never use the plug without the fuse cover fitted.
3. Should you wish to replace a detachable fuse carrier, ensure that the correct replacement is used (as indicated by marking or colour code).
4. Replacement fuse covers can be obtained from your local dealer or most electrical stockists.

## FUSE RATING

The fuse in the plug must be replaced with one of the same rating (**5 amps**) and this replacement must be ASTA approved to BS1362.

**Clarke**<sup>™</sup>  
INTERNATIONAL

## PRINCIPAL PARTS OF THE SCROLL SAW

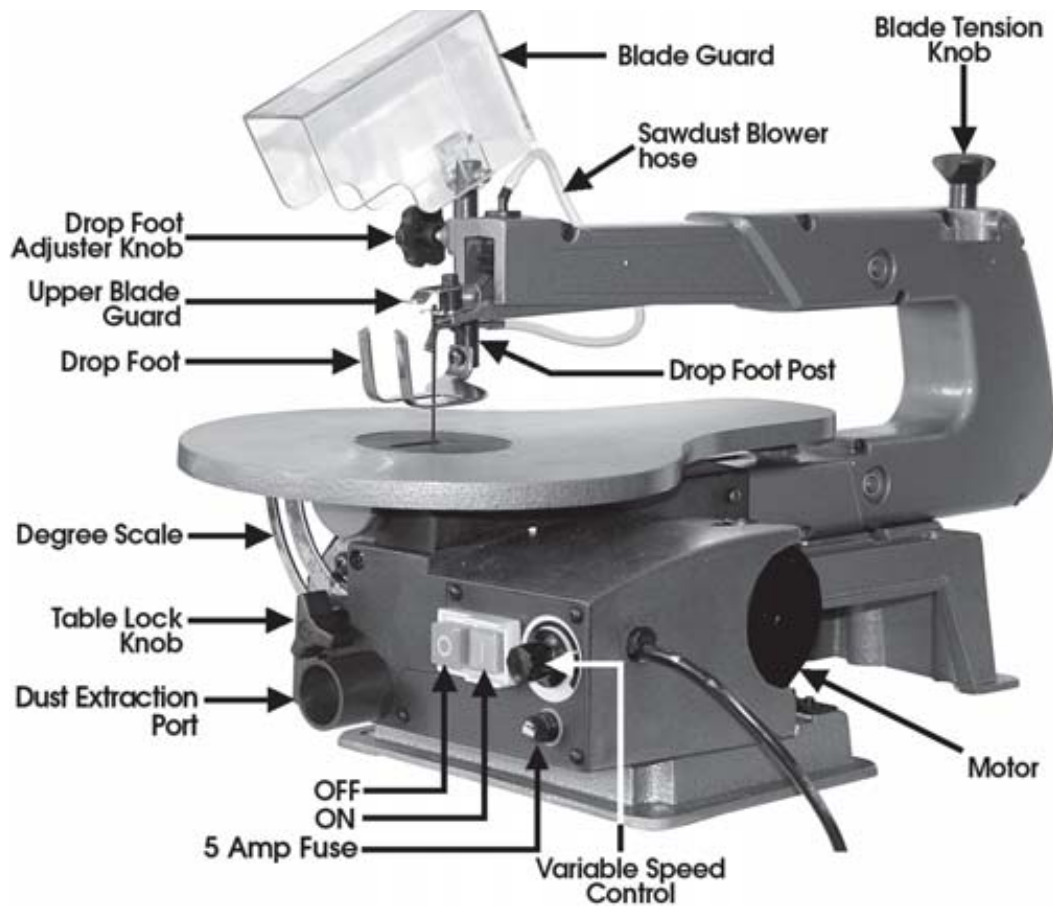

## ASSEMBLY

1. Should the sawdust blower hose not be fitted, attach as shown in Fig.2
2. Line up the hole in the blade guard with the hole at the top of the Drop Foot Post, arrowed at 'A' in Fig. 2. Insert the bolt and screw on the nut. Tighten sufficiently for the nut to be secure with the guard capable of pivoting and dropping under its own weight.
3. It will also be necessary to tighten the Drop Foot securing screw, arrowed at 'B', Fig.2, so that the Drop Foot lies flat/parallel with the table.
4. Check to ensure the Blade Guard is capable of moving fully to its lowest position when the Drop Foot is secure.

Fig. 2

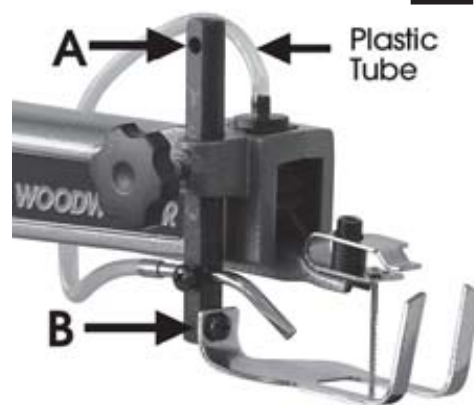

## INSTALLATION (All parts referred to are shown in Fig. 1)

Plan your installation. Ensure adequate space is available, with good lighting and ventilation, and an adequate electrical supply is close at hand.

### 1. MOUNTING THE SAW

Your Scroll Saw is provided with 4 mounting holes, and it is strongly recommended that for safety and stability, you mount the machine either directly to a solid workbench, or to a solid sheet of ply, the best dimensions being - 24" x 14" x ½". The Ply base must then be clamped to a workbench before use.

Ensure you use flat washers between the bolt head and the mounting hole, and do not over tighten the bolts.

### 2. BLADE HOLDER ALIGNMENT

***It is important that the blade holders are checked for alignment before use. Misaligned holders will cause the blade to wander, and reduce the blades' life expectancy.***

To check the alignment,

- 2.1 Loosen the tension on the blade by turning the blade tension knob, two full turns anticlockwise.
- 2.2 Prise out the table insert, by pushing it from beneath the table with your fingers.
- 2.3 Apply a slight downward pressure on the upper arm whilst holding the blade firmly, allowing the pins at the top of the blade to be disengaged from the recesses in the upper blade holder - see fig 3. It is now a simple matter to disengage the blade pins from the lower blade holder and lift the blade out through the access hole in the table.
- 2.4 Remove the side cover, by unscrewing the two retaining screws, (one of which is within the tool holder), to give access to the lower holder.
- 2.5 Slacken off the single hex. socket head screws securing the upper and lower blade holders, (arrowed in fig 3), so that the holders move freely, using the hex socket wrench supplied.
- 2.6 Turn the blade holders, so that they are completely in line with each other and with the table axis. Carefully tighten each holder in turn, taking great care not to alter their positions as you do so.

On completion, replace the side cover, table insert and blade by reversing the procedure above.

***NOTE: If the blade tends to wander during use, re-check this adjustment as it may take one or two attempts to get it right. Also see page 11 - Straight Line Cutting, for other causes of blade wander.***

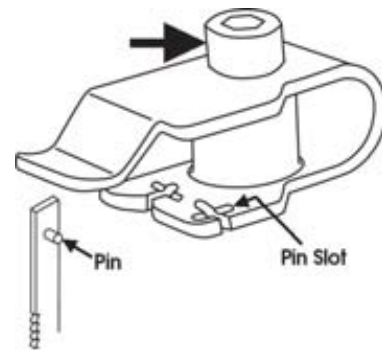

Fig. 3



### 3. BEVEL ALIGNMENT (see fig. 4)

Fig. 4

To align the bevel indicator, loosen the table bevel lock knob, and level the table until it is at right angles to the blade. Use a small square to be sure that the angle between blade and table is 90°.

When the table is perpendicular to the blade, tighten the bevel lock knob.

Loosen the screw holding the pointer, adjust the pointer to 0°, then retighten the screw.

The bevel scale is a convenient indicator, but it is not guaranteed to be 100% accurate. Where absolute accuracy is required, always double check with a protractor before starting a cut.

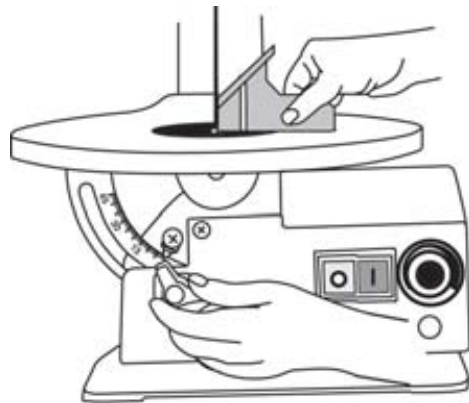

### 4. BLADE INSTALLATION / RENEWAL

- 4.1 Before installing or removing blades, turn OFF the saw and disconnect it from the supply. Remove the blade as described in 2.

#### NOTE:

**The blade slots and pin recesses are made so you can position the blade for cutting from the front, or from the side (see figs. 3). Cutting from the side is necessary when your workpiece is over 16" long.**

**IMPORTANT: Side cutting can only be performed when the table is level, i.e. set to 0°.**

- 4.2 With the blade teeth pointing DOWNWARDS, slot the new blade into the lower housing so that the pins on the end of the blade, engage in the recess in the housing. Holding the blade firmly, apply downward pressure to the upper arm whilst slotting the upper end of the blade into the slot in the upper housing, again, making sure the blade pins correctly engage in the recess in the housing.
- 4.3 Replace the Table Insert, and re-tension to the blade, by turning the tension knob clockwise until you feel the blade is firm. Check to ensure that the blade pins are properly seated, top and bottom.

## OPERATION

Ensure the machine is completely stable...either bolted to a workbench, or with the mounting board clamped firmly to a workbench.

Ensure the table is perfectly secure and at the desired angle and the blade tensioned correctly...ie. tight but not excessively so.

Plug in the mains cable and set the variable speed control to zero..fully anticlockwise.

Place the workpiece on the table and bring the Drop Foot into light contact with the work surface, then tighten the securing screw.

Switch ON by pressing the green knob 'I'. Turn the variable speed control to a desired speed....generally, the harder or thicker the wood, the slower the speed.

Feed the workpiece into the blade gently....do not force it. If there is a need to stop cutting, switch OFF by pressing the red knob 'O', and allow the blade to stop completely before gently working the blade out of the workpiece.

**NOTE: A Dust Port is provided so that a vacuum extraction device may be used.**

## SCROLL SAW OPERATING CHARACTERISTICS

The scroll saw's unique ability is cutting intricate curves which other saws cannot do. A scroll saw can also be used for straight line cutting such as cross cuts, ripping and bevels. The following is a list of points to remember when using a Scroll Saw.

1. The saw does not cut wood by itself. You feed the workpiece into the blade, letting the blade cut the wood as you move the piece ahead.
2. You must guide the wood into the blade SLOWLY, because the teeth are very small, and cut ONLY on the down stroke. If you push the wood into the blade too rapidly, you can easily break the blade.
3. Although the capacity of the saw accepts wood up to 40mm thick, better results are obtained with wood no more than 25mm thick. For wood thicker than 25mm, you must guide the wood into the blade **very slowly**, taking care not to bend or twist the blade.
4. The teeth on the blade will wear out sooner or later. The blade must therefore be replaced often to obtain the best cutting results. A blade will stay sharp for ½ hour to 2 hours of continuous running, depending on the material being cut.
5. Be aware that the blade has a tendency to follow the grain of the wood - the line of least resistance. You can compensate for this by watching the grain carefully and **guiding** the wood past the saw blade.
6. If you are not familiar with scroll saws, there will naturally be a learning period - a period to learn the saw itself, and a period to learn how the wood and saw work together. Expect some blade breakages, Scroll Saw blades are fairly fragile - not the same types of blade you find on a handsaw or circular saw.

## STRAIGHT LINE CUTTING

A little practice will be necessary in order to create a straight line cut. This is due to the very design and nature of the machine itself. The saw blade is quite fragile and due to several different influences, will tend to wander off line. These influences include the following:

1. Blade tension. A slack blade will naturally wander off line.
2. Condition of the blade. A dull blade requires a greater effort to guide it through the work, thereby tending to force it off line.
3. Blade holders misaligned. The holders are secured with a single hex. socket head screw. Slacken the screw and adjust the holder so as to align correctly. The blade should be in line with the table, and not twisted.

**IMPORTANT! Always lower the Drop Foot to make light contact with the work surface, and secure in place before cutting. The Drop Foot may be swivelled so that it may be used when Bevel Cutting.**

## CUTTING INTRICATE PATTERNS

One capability a scroll saw has that other saws do not, is cutting intricate patterns **inside** a workpiece. To do this, you should adopt the following procedure.

1. Drill a 1/4" hole in the middle of the workpiece, in a area which will not be a part of the finished object.
2. Switch off and unplug the machine from the supply.
3. Remove the blade from the machine.
4. Place the workpiece on the table, with the 1/4" hole over the access hole in the table.
5. Replace the blade, through the hole in the workpiece, (teeth downwards), and re-tension the blade.
6. Plug the saw back in. Check to ensure that the workpiece is not touching the blade before switching ON.

When you are finished doing the work inside the workpiece, turn the saw off, unplug it, remove the blade, remove the workpiece, reinstall the blade, and plug the saw back in.

## NOTES ON SAW BLADES

**IMPORTANT: ALWAYS USE GOOD QUALITY BLADES**

### BLADES BREAK FOR FIVE PRINCIPAL REASONS:

1. Too much tension or too little tension on the blade.
2. Overworking the blade by feeding the workpiece too fast.
3. Twisting or bending the blade by feeding the workpiece off-centre.
4. Over use - the blade has reached the end of its useful life.
5. Feeding too much material into the saw, - more than the maximum 2" depth for which it was designed.

### HOW TO DETERMINE THE RIGHT BLADE FOR THE JOB

This scroll saw accepts a wide variety of blade widths and thicknesses. The width of the blade, the thickness of the blade, and the number of teeth per inch (TPI) are determined by the type of material and size of the radius being cut. Here are several examples:

TPI	WIDTH	THICKNESS	MATERIAL
10	2.8mm 0.11"	0.5mm 0.020"	Medium curves on 1/4" to 1-3/4" wood, wallboard, hardboard.
15	2.8mm 0.11"	0.5mm 0.020"	Same as above, plus wood 1/8" to 1-1/2" thick
18	2.4mm 0.095"	0.25mm 0.011	Extra thin cuts on soft woods to 1/4" and parquetry

As a general rule, select the narrowest blades recommended for intricate curve cutting and widest blades for straight and large curve operations.

## MAINTENANCE

- A. Apply a thin coat of paste wax on the work table from time to time. This will help the wood glide across the table more smoothly.
- B. The motor is permanently lubricated. Do not try to oil the motor bearings or service any internal parts of the motor. If the power cord is worn, frayed, cut or damaged, replace it. Do not try to patch it up with electrical tape this could lead to more trouble.

## TROUBLESHOOTING

**IMPORTANT! Whenever carrying out repairs, or Troubleshooting - ALWAYS ensure the electric plug is disconnected from the mains supply.**

PROBLEM	PROBABLE CAUSES	SUGGESTED REMEDY
Breaking Blades.	<ul style="list-style-type: none"> <li>1. Incorrect tension.</li> <li>2. Overworked (worn out) blade.</li> <li>3. Wrong blade being used.</li> <li>4. Twisting blade in wood.</li> </ul>	<ul style="list-style-type: none"> <li>1. Adjust blade tension.</li> <li>2. Reduce feed rate or replace blade.</li> <li>3. Use narrow blades for thin wood, wider blades for thicker wood.</li> <li>4. Avoid side pressure on blade.</li> </ul>
Motor Will Not Run.	<ul style="list-style-type: none"> <li>1. 5 Amp fuse blown</li> <li>2. Defective cord, plug or outlet.</li> <li>3. Defective motor.</li> </ul>	<ul style="list-style-type: none"> <li>1. Check fuses - on front panel. and elec. plug. Replace where necessary. If problem persists contact your Clarke dealer</li> <li>2. Unplug saw, replace defective parts.</li> <li>3. Repairs MUST be made by a qualified technician. Call Clarke Service dept. for advice.</li> </ul>
Excessive Vibration  (Some vibration is inevitable when the saw and motor are running)	<ul style="list-style-type: none"> <li>1. Improper mounting of saw.</li> <li>2. Unsuitable mounting surface.</li> <li>3. Loose table or table rubbing against motor.</li> <li>4. Motor mount is loose.</li> </ul>	<ul style="list-style-type: none"> <li>1. See proper mounting instructions (p7)</li> <li>2. Replace plywood workbench surface with solid lumber surface.</li> <li>3. Tighten table adjuster knob.</li> <li>4. Tighten motor mount screws.</li> </ul>
Blade Runout	<ul style="list-style-type: none"> <li>1. Blade holders not aligned.</li> <li>2. Insufficient Blade tension</li> <li>3. Dull Blade causing excessive force to be used at workpiece</li> </ul>	<ul style="list-style-type: none"> <li>1. Loosen screws holding blade holder to rocker arms. Adjust position of blade holders. Use metal strip to verify alignment. Retighten holder screws</li> <li>2. Increase Blade tension</li> <li>3. Renew Blade and correctly tension.</li> </ul>

## SPECIFICATIONS

Mains Voltage:	230V, 50Hz, 1 phase.
Rating:	120 Watts
Maximum thickness of cut:	50mm (2")
Throat:	400mm (16")
Blade length:	133mm (5¼")
Strokes per minute:	400 - 1700
Stroke length:	15mm
Table size:	413 x 250mm
Machine dimensions (LxWxH):	625x285x320mm
Table tilt:	0° - 45° left
Base size:	400 x 245mm
Blade Type:	Pin
Gross / Net weight:	14 / 16kg

Please note that the details and specifications contained herein, are correct at the time of going to print. However, CLARKE International reserve the right to change specifications at any time without prior notice. Always consult the machine's data plate

## ACCESSORIES

Replacement saw blades are available from you Clarke dealer, in packs of 10, as follows:

10 TPI	Part No. 6470067
15 TPI	Part No. 6460110
20TPI	Part No. 6470072

## PARTS & SERVICE CONTACTS

For Spare Parts and Service, please contact your nearest dealer,  
or CLARKE International, on one of the following numbers.

**PARTS & SERVICE TEL: 020 8988 7400**

**PARTS & SERVICE FAX: 020 8558 3622**

or e-mail as follows:

**PARTS: [Parts@clarkeinternational.com](mailto:Parts@clarkeinternational.com)**

**SERVICE: [Service@clarkeinternational.com](mailto:Service@clarkeinternational.com)**

## PARTS LIST

No.	Description	Part No.	No.	Description	Part No.
1	PCB	DDCSS16V01	47	Blade Box	DDCSS16V47
2	Power Cable complete	DDCSS16V02	49	Fuse Holder	DDCSS16V49
4	Hex Nut M6	DDCSS16V04	50	Switch Cover	DDCSS16V50
5	Pan Head Screw M5x10	DDCSS16V05	51	Motor	DDCSS16V51
6	Plate Cover	DDCSS16V06	52	Eccentric	DDCSS16V52
8	Hex Head Screw M8x25	DDCSS16V08	53	Table	DDCSS16V53
9	Base	DDCSS16V09	54	Hex Hd Bolt M6x35	DDCSS16V54
10	Hex Head Screw M6x16	DDCSS16V010	55	PVC Pipe	DDCSS16V55
11	Housing Complete	DDCSS16V11	56	Support Rod	DDCSS16V56
12	Table Support	DDCSS16V12	57	Bellows Top	DDCSS16V57
13	Indicator	DDCSS16V13	58	Bellows	DDCSS16V58
14	Pan Head Screw M6x12	DDCSS16V14	59	Tooth Washer	DDCSS16V59
15	Quadrant	DDCSS16V15	60	Set Screw M8x8	DDCSS16V60
17	Spring	DDCSS16V17	61	Pan Hd Screw St4.2x8	DDCSS16V61
19	Hex Head Bolt M6x40	DDCSS16V19	62	Fuse	DDCSS16V62
20	Spring	DDCSS16V20	63	Pan Hd Screw M5x8	DDCSS16V63
21	Bolt Tension Knob	DDCSS16V21	64	Pan Hd Screw M4x6	DDCSS16V64
22	Lower Arm	DDCSS16V22	65	Pan Hd Screw M5x35	DDCSS16V65
24	Hex Head Bolt M4x10	DDCSS16V24	66	Pan Hd Screw M5x30	DDCSS16V66
25	Bearing Flange	DDCSS16V25	67	Blower Tube	DDCSS16V67
26	Pan Head Screw M5x6	DDCSS16V26	68	Knob	DDCSS16V68
27	Round Hd Screw M6x25	DDCSS16V27	69	Bearing Fence	DDCSS16V69
28	Retainer	DDCSS16V28	70	Set Plate	DDCSS16V70
29	Upper Arm	DDCSS16V29	71	Switch Case	DDCSS16V71
30	Hex Nut M6	DDCSS16V30	72	Switch	DDCSS16V72
31	Hex Head Bolt M5x20	DDCSS16V31	73	Hex Nut M5	DDCSS16V73
32	Spacer Bearing	DDCSS16V32	74	Pan Head Screw	DDCSS16V74
33	Big Plate Washer	DDCSS16V33	75	Back Plate Cover	DDCSS16V75
34	Link Assembly	DDCSS16V34	77	Hex Head Bolt M4x16	DDCSS16V77
35	Allen Wrench	DDCSS16V35	78	Guard Blade	DDCSS16V78
36	Cord Clamp	DDCSS16V36	79	Speed Switch	DDCSS16V79
37	Upper Blade Holder	DDCSS16V37	81	Knob	DDCSS16V81
38	Hex Head Bolt M5x25	DDCSS16V38	82	Pan Hd Screw M5x25	DDCSS16V82
40	Tube	DDCSS16V40	83	Carbon Brush	DDCSS16V83
41	Pan Head Screw	DDCSS16V41	84	Brush Screw	DDCSS16V84
42	Hex Head Bolt M4x16	DDCSS16V42	85	Tooth Washer	DDCSS16V85
43	Table Insert	DDCSS16V43	87	Drop Foot	DDCSS16V87
44	Knob	DDCSS16V44	88	Bearing	DDCSS16V88
45	Blade	<b>See Accessories</b>			
46	Pan Hd Screw M4x10	DDCSS16V46			

# PARTS DIAGRAM

