

Clarke[®]

CONTRACTOR[®]



12mm SOFT START ROUTER

MODEL No. CR2

Part No. 6462075

OPERATING & MAINTENANCE INSTRUCTIONS



0706

IMPORTANT NOTE:

This manual is intended to instruct the user on the operations peculiar to the CR2 Router ONLY. Although some reference is made to routing applications, it should not be regarded as a general tutorial on the subject.

It is assumed that the user has some knowledge of tools of this type, and is familiar with routing techniques and applications. If this is not the case, we strongly recommend that the user seek professional advice and tuition before using this tool.

SPECIFICATIONS

Elec. Supply	230V 50Hz 1 ph
Elec. Class	II
Motor Power Rating	2100W
Fuse Rating	13amp
No Load Speed	7,400-21,600 RPM *
Max. Plunge Depth	60 mm
Collet Size - Fitted	1/2"
Dust Extraction Adapter Port Size	22mm
Net Weight	6.5 kg
Guaranteed Sound Power Level:	107.3 dBL _{WA}
Vibration Level	4.7m/s ² **
Dimensions	319x323x140

* **Speed Settings are shown on page 12.**

** **See Vibration Emission notes on pages 16 and 27**

Please note that the details and specifications contained herein, are correct at the time of going to print. However, CLARKE International reserve the right to change specifications at any time without prior notice.

CHECK LIST

1 x Carry case.	1 x 16mm Template Guide Bush.
1 x User Instruction Manual.	1 x 30 mm Template Guide Bush.
1 x Router.	15 x Cutting Bits (Various).
1 x Parallel Fence.	1 x 1/4" collet
2 x Guide Rods.	1 x 3/8" collet
1 x Spanner.	(1 x 1/2" collet - fitted)



© Copyright Clarke International. All rights reserved, March 2006
When disposing of this product, do not dispose of with normal household waste. Dispose of according to all local ordinances



Thank you for purchasing this CLARKE Soft Start Router which is designed for DIY and light industrial use ONLY, for routing wood, wood products and plastic.

Before attempting to use the machine, please read this manual thoroughly and follow the instructions carefully. In doing so you will ensure the safety of yourself and that of others around you, and you can look forward to the router giving you long and satisfactory service.

GUARANTEE

This product is guaranteed against faulty manufacture for a period of 12 months from the date of purchase. Please keep your receipt which will be required as proof of purchase.

This guarantee is invalid if the product is found to have been abused or tampered with in any way, or not used for the purpose for which it was intended.

Faulty goods should be returned to their place of purchase, no product can be returned to us without prior permission.

This guarantee does not effect your statutory rights.

CONTENTS

Specifications	2
Safety Precautions for Power Tools	4
Additional Safety Precautions for Routers	5
Electrical Connections	6
Assembly Instructions	7
Adjustments	9
Depth of Cut	9
Multi-Stop Turret	10
Micro-Adjuster	10
Operation	11
Cutter Speeds	12
Troubleshooting	12
Maintenance	12
Parts and Service Contacts	13
Parts Lists and Diagrams	14 - 15
Vibration Emission Notes	16
Declaration of Conformity	17

SAFETY PRECAUTIONS



WARNING:

As with all machinery, there are certain hazards involved with their operation and use. Exercising respect and caution will considerably lessen the risk of personal injury. However, if normal safety precautions are overlooked or ignored, personal injury to the operator or damage to property, may result.

1. **ALWAYS** learn the machines applications, limitations and the specific potential hazards peculiar to it. Read and become familiar with the entire operating manual.
2. **ALWAYS** use a face or dust mask if operation is particularly dusty.
3. **ALWAYS** check for damage. Before using the machine, any damaged part, should be checked to ensure that it will operate properly, and perform its intended function. Check for alignment of moving parts, breakage of parts, mountings, and any other condition that may affect the machines' operation. Any damage should be properly repaired or the part replaced. If in doubt, **DO NOT** use the machine. Consult your local dealer.
4. **ALWAYS** disconnect the tool/machine from the power supply before servicing and when changing accessories.
5. **ALWAYS** wear safety goggles, manufactured to the latest European Safety Standards. Everyday eyeglasses do not have impact resistant lenses, they are not safety glasses.
6. **ALWAYS** keep work area clean. Cluttered areas and benches invite accidents.
7. **ALWAYS** ensure that adequate lighting is available. A minimum intensity of 300 lux should be provided. Ensure that lighting is placed so that you will not be working in your own shadow.
8. **ALWAYS** keep children away. All visitors should be kept a safe distance from the work area, especially whilst operating the machine.
9. **ALWAYS** maintain machine in top condition. Keep tools/machines clean for the best and safest performance. Follow maintenance instructions.
10. **ALWAYS** handle with extreme care do not carry the tool/machine by it's electric cable, or yank the cable to disconnect it from the power supply .
11. **ALWAYS** ensure the switch is off before plugging in to mains. Avoid accidental starting.
12. **ALWAYS** concentrate on the job in hand, no matter how trivial it may seem. Be aware that accidents are caused by carelessness due to familiarity.
13. **ALWAYS** keep your proper footing and balance at all times - don't overreach. For Best footing, wear rubber

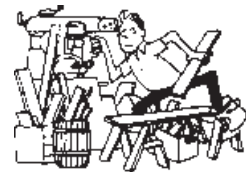

14. **ALWAYS** wear proper apparel, loose clothing or jewellery may get caught in moving parts. Wear protective hair covering to contain long hair.
15. **ALWAYS** use recommended accessories. The use of improper accessories could be hazardous.
16. **ALWAYS** remove plug from electrical outlet when adjusting, changing parts, or working on the machine.
17. **ALWAYS** keep handles clean and free from oil and grease.
18. **NEVER** leave machine running unattended. Turn power off. Do not leave the machine until it comes to a complete stop.
19. **NEVER** force the machine. It will do a better and safer job at the rate for which it was designed.
20. **NEVER** use power tools in damp or wet locations or expose them to rain. Keep your work area well illuminated. Do not use in explosive atmosphere (around paint, flammable liquids etc.). Avoid dangerous environment.
21. **NEVER** operate machine while under the influence of drugs, alcohol or any medication.



ADDITIONAL PRECAUTIONS FOR ROUTERS

1. **ALWAYS** wear ear protectors/defenders as the noise level of this machine can exceed 95dB_{LWA}
 2. **ALWAYS** use the appropriate cutter etc., for the material being cut.
 3. **ALWAYS** keep the mains cable well away from the machine and ensure an adequate electrical supply is close at hand so that the operation is not restricted by the length of the cable.
 4. **ALWAYS** switch the machine OFF immediately the task is completed.
 5. **ALWAYS** use cutters with a shank diameter corresponding to the collet installed in your machine.
 6. **ALWAYS** allow sufficient clearance beneath the work to ensure the cutter does not come into contact with the floor, table etc.
 7. **ALWAYS** ensure the cutter is fully tightened before use.
 8. **NEVER** allow the ventilation slots in the machine to become blocked.
 9. **NEVER** use the machine if the electric cable, plug or motor is in poor condition.
 10. **NEVER** remove router from work until the cutter has completely stopped.
 11. **NEVER** use the router on second hand timber, e.g. doors, floorboards etc. unless all nails, screws and staples have been removed beforehand. Nails will severely damage the cutter.
- NOTE : Replacement cutters are available from your CLARKE dealer.**

WARNING: The use of spare parts or accessories, other than those supplied by CLARKE International or one of its recognised dealers, may be hazardous and could invalidate the guarantee.

Additionally, please keep these instructions in a safe place for future reference.

ELECTRICAL CONNECTIONS

This product is provided with a standard 13 amp, 230 volt (50Hz), BS 1363 plug, for connection to a standard, domestic electrical supply. Should the plug need changing at any time, ensure that a plug of identical specification is used.



This appliance is Double Insulated, and the two wires in the mains lead should be wired up in accordance with the following colour code:

BLUE - NEUTRAL

BROWN - LIVE

- Connect the BLUE coloured cord to the plug terminal marked a letter "N"
- Connect the BROWN coloured cord to the plug terminal marked a letter "L"

If this appliance is fitted with a plug which is moulded on to the electric cable (i.e. non-rewireable) please note:

1. The plug must be thrown away if it is cut from the electric cable. There is a danger of electric shock if it is subsequently inserted into a socket outlet.
2. Never use the plug without the fuse cover fitted.
3. Should you wish to replace a detachable fuse carrier, ensure that the correct replacement is used (as indicated by marking or colour code).
4. Replacement fuse covers can be obtained from your local Clarke dealer or most electrical stockists.



FUSE RATING

The fuse in the plug must be replaced with one of the same rating (**13 amps**) and this replacement must be ASTA approved to BS1362.

If in doubt, consult a qualified electrician. Do not attempt any electrical repairs yourself.

CABLE EXTENSION.

Always use an approved cable extension suitable for the power rating of this tool (see specifications), the conductor size should also be at least the same size as that on the machine, or larger. When using a cable reel, always unwind the cable completely.

PARTS & SERVICE CONTACTS

For Spare Parts and Service, please contact your nearest dealer,
or CLARKE International, on one of the following numbers.

PARTS & SERVICE TEL: 020 8988 7400

PARTS & SERVICE FAX: 020 8558 3622

or e-mail as follows:

PARTS: Parts@clarkeinternational.com

SERVICE: Service@clarkeinternational.com

ASSEMBLY

Fig. 1

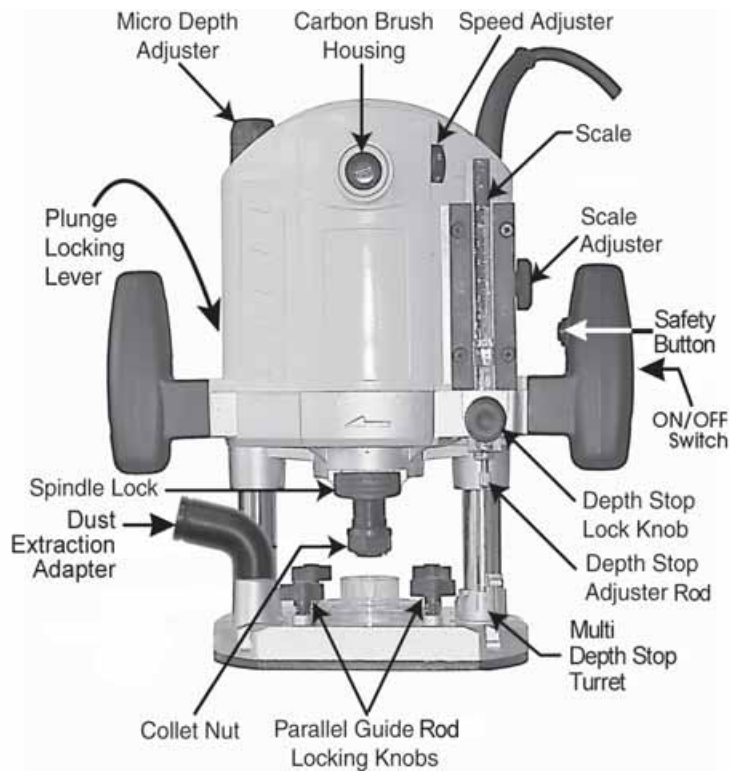

Note :

Always ensure router is isolated from the mains supply, by switching off and removing the plug from the socket.

1. Installing And Changing Router Bits

- 1.1 Rotate spindle whilst pushing the spindle lock inwards until spindle is locked, (hold lock on).
- 1.2 Using the wrench supplied, loosen the collet nut a few turns and remove bit if fitted.
- 1.3 Insert new bit and tighten collet nut, release spindle lock.

IMPORTANT: At least two thirds of the cutter shank should be located inside the collet .



WARNING



**Never tighten the collet nut without a router bit inserted
(Damage to the Collet will result)**

2. Fitting The Parallel Guide

2.1 Insert the rods into the guide body, securing with the screws provided

2.2 Fit the assembled guide to the router as shown in Fig. 3.

2.3 Secure using the locking screws provided

NOTE: The parallel guide allows the user to follow a straight edge with accuracy.

It is always advisable to make a trial cut in a piece similar to that to be worked where possible.

Precise measurements are possible, using the microadjuster, indicated in Fig.2.

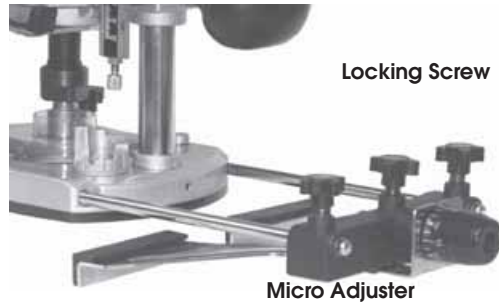

Fig. 2

3. Fitting The Template Guide Bush

Fit the template guide, to the router base from underneath, as shown in Fig.3, with the screws used to secure the transparent plastic dust cover.

Replace the screws and tighten, taking care not to overtighten.

NOTE: The Guide Bush allows the user to duplicate a particular shape, that shape being used as a template.

The template is fixed firmly to the workpiece and the complete assembly fixed firmly to a workbench. The Router is moved along the edge of the template with the guide held carefully against its edge. Because the diameter of the guide is larger than the cutter, there will be always be a certain offset to consider.



Fig. 3

4. Fitting The Roller Guide

A Roller Guide is provided which replaces the parallel Guide. This provides greater versatility, allowing either straight line cuts, or contour cutting to take place, depending upon the shape of the template.

To assemble the guide, proceed as follows:

4.1 Remove the parallel fence by unscrewing and pulling off the Microadjuster knob, as illustrated in Fig.4.



Fig. 4



Fig. 5

3.2 Undo and remove the two screws securing the Keep Plate, arrowed in Fig.5.

3.3 Replace the parallel Fence with the Roller Guide, in the manner shown in Fig.6, ensuring it slides neatly and freely on the base.

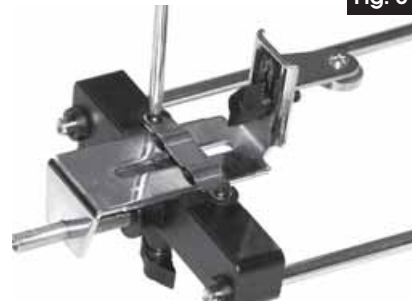

Fig. 6



Fig. 7

3.4 The roller follows either a template, or the edge of the workpiece, as shown in Fig.7.

ADJUSTMENTS

Setting Depth Of Cut for Plunge Routing

With the appropriate cutter installed, noting that plunge cutters and combination plunge and side cutters are available, proceed as follows:

1. Release the plunge locking Lever (see Fig. 1) to allow the main body to rise to its fullest extent.

NOTE: The main body is fully extended, when there is no load on the microadjuster. Turn the microadjuster anticlockwise so that when the main body is fully extended, the adjuster may be easily turned clockwise AND anticlockwise.

2. If necessary, raise the scale (simply loosen the depth stop lock knob in order to pull it upwards) so that the adjuster rod, see Fig.7, is clear of the multi stop turret, then turn the turret to the highest position directly beneath the adjuster rod.
3. With the router resting on the workpiece, pull back the plunge locking lever and gently plunge the router until the cutter just touches the work surface, ensuring the adjuster rod does not make contact with the turret. Release the plunge locking lever to lock it in place.

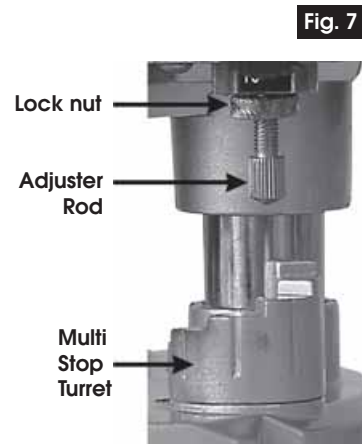

Fig. 7

4. Slacken the Depth Stop Lock Knob and push the scale down until the Adjuster Rod touches the highest step possible on the turret.
5. Line the red line on the scale magnifier with one of the graduations on the scale...zero if it is available, then, holding the magnifier steady, wind the scale up, using the scale adjuster, the number of graduations, as viewed in the magnifier, commensurate with the total depth of cut required - 1 graduation = 1mm
Lock the scale (and hence the adjuster rod) by tightening the Depth Stop Lock Knob.
Your Plunger is now set.

NOTE:

When making a deep cut, it is advisable to make more than one pass to achieve the desired depth. The depth of cut achievable with each pass depends greatly on the size of cutter and the material being worked. Excessive depth of cut will unduly labour the motor, place excessive strain on the cutter, make the router more difficult to control and significantly reduce the quality of the cut being made.

The multi depth stop turret can be used to assist in making multiple passes.

Using the turret in this manner removes the necessity for resetting the adjuster rod for each pass. Each stop on the turret is approx. 3mm.

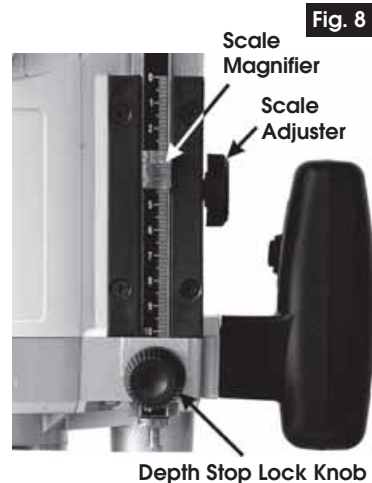

Using The Multi-Stop Turret

When using the turret stop, the depth of cut should be set using one of the lower steps on the turret (see above).

With the total depth set, the router is raised fully and the turret turned to a higher step to restrict the depth of cut, as required, until the final cut is made from the original turret step.

Take a test plunge (see Operation) and measure the depth. Small adjustments can be made by adjusting the micro adjuster on the top of the machine.

Using The Microadjuster

Each graduation on the microadjuster scale = 1mm, i.e. from 1 to 2 =10mm.

The microadjuster is zeroed by holding the knob whilst turning the registration collar (see Fig.9) which will move independently of the knob when held. This may be very stiff when new.

Ensure there is no load on the microadjuster knob - it should turn freely in both directions...if not, unscrew (turn anticlockwise) until it does, then carefully turn it clockwise until reasonable resistance is felt.

At this point, hold the knob whilst turning the registration collar to register zero then release the collar so that the knob and collar turn as one.

Advancing the knob further will increase the depth of cut by 1mm per graduation.

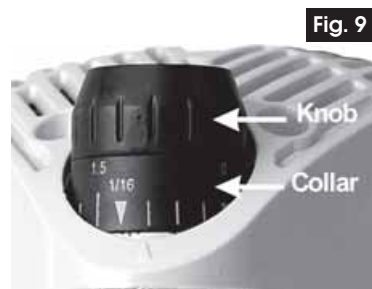

OPERATION

General

1. Always ensure the workpiece is firmly secured.
2. Place router on the workpiece with the cutter in the position to be cut, e.g. cutter just in front of start position - for edge profiling, and the guide firmly pushed up to edge of the work.
3. With the router held firmly, pull and hold the plunge locking lever then push down on the plunger body fully....the depth stop should be pre-set. At this point, release the plunge locking lever, and tighten to lock the cutter at its predetermined depth.
4. Switch the router on by pushing the safety button IN - see Fig.1, and pulling the ON/OFF trigger switch. Allow the motor to reach full speed. (The speed controller is located on the top of the router (see Fig. 1), The higher the number the greater the speed. See Cutter Speed Selection on page 12. Proceed to feed the cutter into the workpiece.
To stop the Router, simply release the trigger.

Fig.10

Direction Of Feed

The router motor and therefore the cutter, revolves in a clockwise direction. This gives the tool a tendency to twist anticlockwise in your hands, particularly when starting the tool.

The Router should always be moved from **left to right** as you are facing the workpiece see Fig.10.

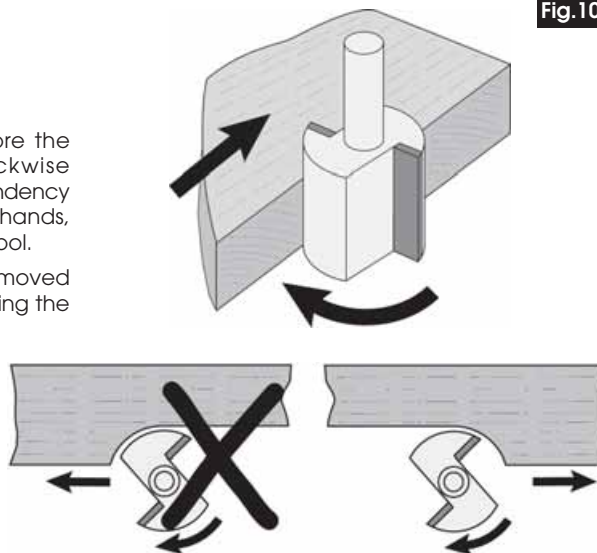

Feed Rate

The rate at which the router is moved across the material has a significant effect on the quality of cut and the length of service you will get from your router and cutters.

Moving too fast through the cut could overload and damage the cutter, causing a rough and uneven finish.

Moving too slowly, tends to cause burning of the material and if excessive, will cause the cutter to overheat, therefore blunting and shortening its expected life.

The proper feed rate to use depends on the cutter size, the material being cut, the depth of the cut and the speed selected.

With all these variables, the surest way to ensure that you get the best quality and efficiency of cut, is to practice on a piece of scrap of the same material to get a feel for what feed rate to use. This will also show you exactly how the cut will look and allow you to check the cutting depth.

Cutter Speed Selection

The greater the diameter of the cutter, the slower the rotational speed. This is in order to produce as constant speed as possible at the cutting edge.
Recommendations for this Router are as follows, for soft wood:

<u>Diameter</u>	<u>Speed Setting</u>	<u>Speed</u>
Up to 25mm	6	21,600RPM
25 - 35mm	5	21,000RPM
25 - 50mm	4	18,000RPM
50 - 65mm	3	16,000RPM
65 - 75mm	2	12,000RPM
Over 75mm	1	7,400RPM

Only use cutters of the correct shank diameter and are suitable for the max. speed for this Router

TROUBLE SHOOTING

Router is overheating

This indicates the machine is dirty. Clean the ventilation holes, and blow out with compressed air or clean with a dry cloth.

Overloading the machine will also cause overheating. Do not use for heavy duty work, and do not apply excessive pressure.

Excessive sparking occurs

This indicates worn brushes. This problem is quickly remedied but you should consult your CLARKE dealer for parts and advice.

Router does not operate when switched ON

Check to ensure the fuse is sound and replace if necessary. If the fuse is sound or blows repeatedly, consult your CLARKE dealer.

MAINTENANCE

Always inspect the tool before use, and ensure it is in top condition.

Ensure all air vents are clear, (use compressed air to clean the machine where possible). Check the power cable to ensure it is sound and free from cracks, bare wires etc. avoid using solvents when cleaning plastic parts, most plastics are susceptible to damage from the various types of commercial solvents.

All bearings etc., in this tool are lubricated with a sufficient amount of high grade lubricant for the tools lifetime under normal operating conditions, therefore no further lubrication is required.

Dust Extraction

The Router is provided with a dust extraction outlet, where a vacuum extractor may be connected. An adapter is provided for this purpose. Please note however, that this does not preclude the user from wearing a face mask to prevent the inhalation of dust particles.

It is an EU requirement that a dust extraction facility be provided on power tools, however, due to the nature of the tool, some of the dust produced will be forced into the surrounding atmosphere, and will not be collected. Always therefore wear a face mask.

No.	Description	Qty	Part No	No.	Description	Qty	Part No
101	Screw M4x10	6	HTCR2101	234	Switch	1	HTCR2234
102	Base Pad	1	HTCR2102	235	Plastic Tube	1	HTCR2235
103	Screw M5x10	9	HTCR2103	236	Pin	1	HTCR2236
104	Transparent Cover	1	HTCR2104	237	Tube	1	HTCR2237
105	Butterfly Screw	6	HTCR2105	238	C-ring	1	HTCR2238
106	Tube	1	HTCR2106	239	Right Handle Cover	1	HTCR2239
107	Screw M6x12	2	HTCR2107	240	Right Handle	1	HTCR2240
108	Dust Port	1	HTCR2108	241	Spring	1	HTCR2241
109	Tube	1	HTCR2109	301	Screw	2	HTCR2301
110	Circlip	2	HTCR2110	302	Micro Adjuster Knob	1	HTCR2302
111	Spring	1	HTCR2111	303	Screw	9	HTCR2303
112	Adjuster Nut	1	HTCR2112	304	Top Cover	1	HTCR2304
113	C-ring	1	HTCR2113	305	Inductance	2	HTCR2305
114	Spring Tube	1	HTCR2114	306	Rubber Bush	1	HTCR2306
115	Washer	1	HTCR2115	307	Cable Clamp	1	HTCR2307
116	Adjuster Bolt	1	HTCR2116	308	Screw M4x16	5	HTCR2308
117	Tube	1	HTCR2117	309	Housing	1	HTCR2309
118	C-ring	1	HTCR2118	310	Brush Holder	2	HTCR2310
201	Power Cord	1	HTCR2201	311	Carbon Brush	2	HTCR2311
202	Soft Start	1	HTCR2202	316	Washer 05	2	HTCR2316
203	Terminal Block	1	HTCR2203	317	Spring Washer	2	HTCR2317
204	Screw	4	HTCR2204	318	Screw M5x80	2	HTCR2318
205	Left Depth Frame	1	HTCR2205	319	Sleeve	1	HTCR2319
206	Right Depth Frame	1	HTCR2206	320	Screw M5x40	4	HTCR2320
207	Fan Cover	1	HTCR2207	321	Left Handle Cover	1	HTCR2321
208	Scale Magnifier	1	HTCR2208	322	Left Handle	1	HTCR2322
209	Scale Adjuster Knob	1	HTCR2209	323	Screw	1	HTCR2323
210	Bearing Sleeve	1	HTCR2210	324	Twist Spring	1	HTCR2324
211	Bearing	1	HTCR2211	325	Release Lever	1	HTCR2325
212	Scale	1	HTCR2212	326	Screw M5x4	1	HTCR2326
213	Armature	1	HTCR2213	327	Middle Cover	1	HTCR2327
214	Slide	1	HTCR2214	328	Screw	4	HTCR2328
215	Lock Nut	1	HTCR2215	329	Frame Spring	2	HTCR2329
216	Microadjuster Screw	1	HTCR2216	330	Lock-pin	1	HTCR2330
217	Bearing Cover	1	HTCR2217	331	Lock-pin	1	HTCR2331
218	Tube Cover	2	HTCR2218	501	Adjuster Knob	1	HTCR2501
219	Base	1	HTCR2219	502	Rubber Insert	1	HTCR2502
220	Ball Bearing	1	HTCR2220	503	Adjuster Knob	1	HTCR2503
221	Spring	1	HTCR2221	504	Screw	2	HTCR2504
222	Steel Ball	1	HTCR2222	505	Clip	1	HTCR2505
223	Turret Stop	1	HTCR2223	506	Side Fence Frame	1	HTCR2506
224	Dustproof Cover	1	HTCR2224	507	Parallel Guide	2	HTCR2507
225	Spring	7	HTCR2225	508	Slide Frame 08	1	HTCR2508
226	1/2" Collet	1	HTCR2226	509	Flat Washer	2	HTCR2509
227	Clamp Nut	1	HTCR2227	510	Csk Head Screw	4	HTCR2510
228	Screw	1	HTCR2228	511	Body	1	HTCR2511
229	C-ring	1	HTCR2229	512	Adjuster Screw	1	HTCR2512
230	Insulation Cover	1	HTCR2230	513	Slider Rod	2	HTCR2513
231	Junction Box	1	HTCR2231	514	1/4" Collet	1	HTCR2514
232	Clip	1	HTCR2232	515	Wrench	1	HTCR2515
233	Depth Lock Knob	1	HTCR2233	516	Template Guide	1	HTCR2516

PARTS DIAGRAM

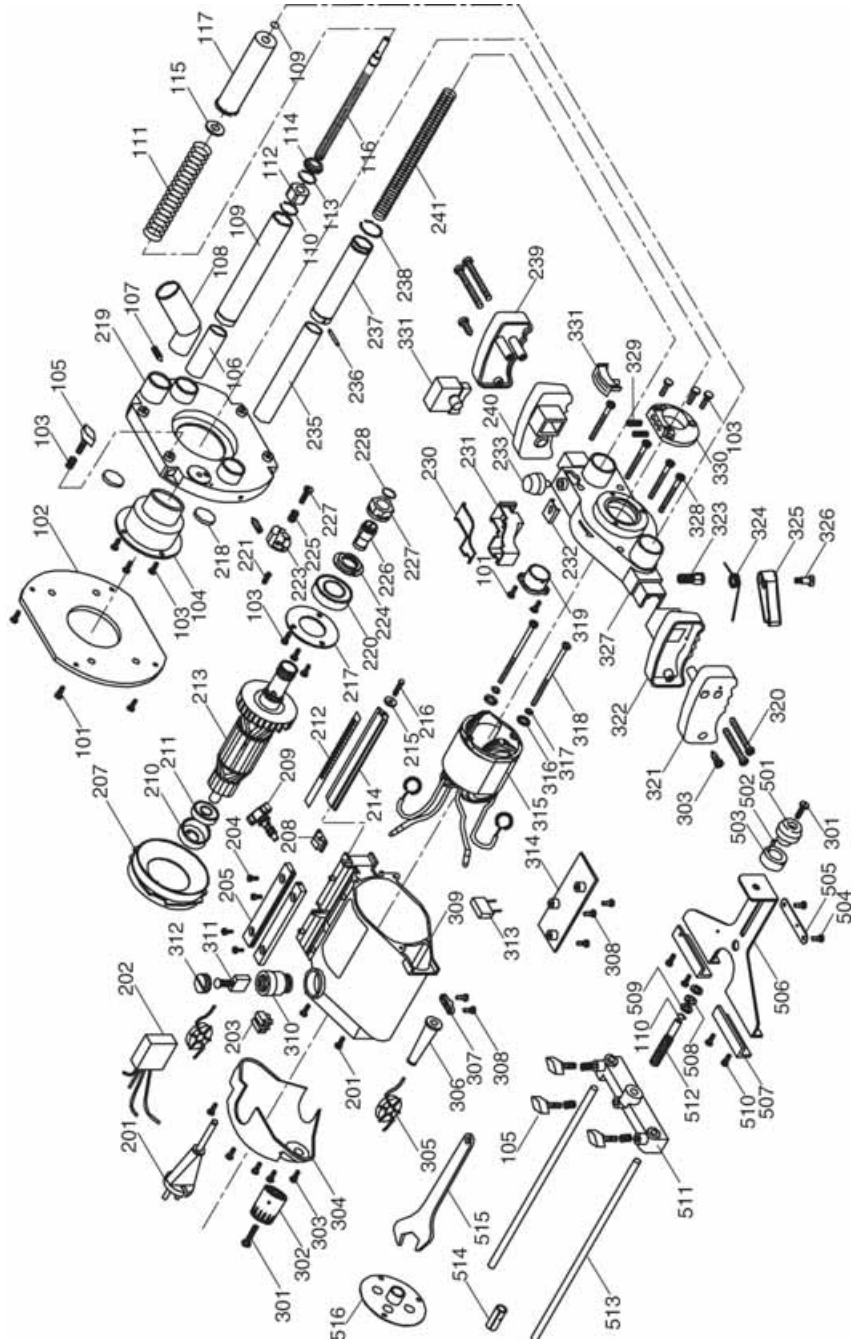

VIBRATION EMISSIONS

HAND-ARM VIBRATION

Employers are advised to refer to the HSE publication "Guide for Employers".

All hand held power tools vibrate to some extent, and this vibration is transmitted to the operator via the handle, or hand used to steady the tool. Vibration from about 2 to 1500 herz is potentially damaging and is most hazardous in the range from about 5 to 20 herz.

Operators who are regularly exposed to vibration may suffer from Hand Arm Vibration Syndrome (HAVS), which includes 'dead hand', 'dead finger', and 'white finger'. These are painful conditions and are widespread in industries where vibrating tools are used.

The health risk depends upon the vibration level and the length of time of exposure to it.....in effect, a daily vibration dose.

Tools are tested using specialised equipment, to approximate the vibration level generated under normal, acceptable operating conditions for the tool in question. For example, a grinder used at 45° on mild steel plate, or a sander on soft wood in a horizontal plane etc.

These tests produce a value 'a', expressed in metres per second per second, which represents the average vibration level of all tests taken, in three axes where necessary, and a second figure 'K', which represents the uncertainty factor, i.e. a value in excess of 'a', to which the tool could vibrate under normal conditions. These values appear in the specification panel below.

MODEL No:	CR2
DESCRIPTION:	PLUNGE ROUTER
Declared vibration emission value in accordance with EN12096	
Measured vibration emission value - a :	4.7 m/s ²
Value determined according to EN28622-1	

You will note that a third value is given in the specification - the highest measured reading in a single plane. This is the maximum level of vibration measured during testing in one of the axes, and this should also be taken into account when making a risk assessment.

'a' values in excess of 2.5 m/s² are considered hazardous when used for prolonged periods. A tool with a vibration value of 2.8 m/s² may be used for up to 8 hours (cumulative) per day, whereas a tool with a value of 11.2 m/s² may be used for ½ hour per day only.

The graph below shows the vibration value against the maximum time the respective tool may be used, per day.

The uncertainty factor should also be taken into account when assessing a risk. The two figures 'a' and 'K' may be added together and the resultant value used to assess the risk.

It should be noted that if a tool is used under abnormal, or unusual conditions, then the vibration level could possibly increase significantly. Users must always take this into account and make their own risk assessment, using the graph above as a reference.

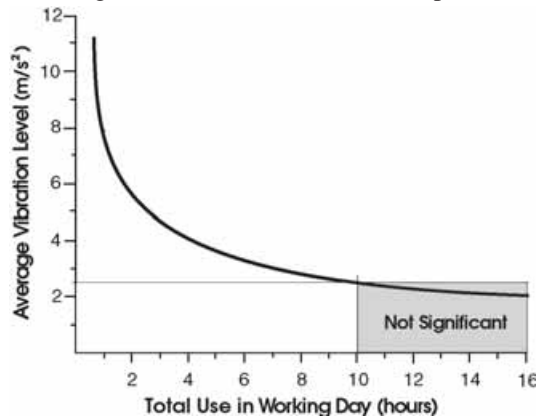

Some tools with a high vibration value, such as impact wrenches, are generally used for a few seconds at a time, therefore the cumulative time may only be in the order of a few minutes per day. Nevertheless, the cumulative effect, particularly when added to that of other hand held power tools that may be used, must always be taken into account when the total daily dose rate is determined.

DECLARATION OF CONFORMITY

We declare that this product complies to the following standards/directives:

- **98/37/EC**
- **BS EN 60745-1:2003**
- **BS EN 60745-1-17:2003**

Product Description: ROUTER
Model No: CR2
Serial (Batch) No: See Product Data Plate

Signed 
L E Fergusson
 Engineering Manager

Clarke INTERNATIONAL
 Hemnall Street, Epping, Essex CM16 4LG

Clarke International is a trading style of Clarke International Limited