

ClarkeTM WOODWORKER

CMS 200 COMPOUND MITRE SAW



OPERATING & MAINTENANCE INSTRUCTIONS

Product Serial/Batch No.



0401



**PLEASE READ THIS MANUAL THOROUGHLY
BEFORE USE.**

**If you have any problems using, or setting up
this machine,
ring this number...020 8988 7400**

- Press 1 for Parts
- Press 2 for Technical Assistance

WARNING!

Due to the gearing arrangement, this machine generates considerable noise. Do not be alarmed as this is quite normal for this type of machine.

We strongly recommend that you wear ear defenders during use.

PARTS & SERVICING

For Parts & Servicing, please contact your nearest dealer, or CLARKE International, on one of the following numbers.

PARTS & SERVICE TEL: 020 8988 7400

PARTS & SERVICE FAX: 020 8558 3622

or e-mail as follows:

PARTS: Parts@clarkeinternational.com

SERVICE: Service@clarkeinternational.com

Thank you for purchasing this CLARKE 8 inch Compound Mitre Saw which is designed for DIY/Hobby use only.

Before operating the Mitre Saw please read this leaflet thoroughly and carefully follow all instructions. This will ensure the safety of yourself and that of others around you, and you can also look forward to the machine giving you long and satisfactory service.

GUARANTEE

This CLARKE product is guaranteed against faulty manufacture for a period of 12 months from the date of purchase. Please keep your receipt as proof of purchase. This guarantee is invalid if the product is found to have been abused or tampered with in any way, or not used for the purpose for which it was intended.

Faulty goods should be returned to their place of purchase, no product can be returned to us without prior permission.

This guarantee does not effect your statutory rights.

CONTENTS Page

Safety Precautions	4
Additional Precautions for Mitre Saws	6
Electrical Connections	7
Principle Parts	8
Features	9
Assembly	10
Operation	Cross Cutting 10
	Mitre Cutting 11
	Bevel Cutting 12
	Compound Mitre Cutting 12
Maintenance	13
	Blade renewal 13
Adjustments	15
Specifications	15
Maximum Cutting Sizes	15
Parts Lists and Diagrams	16 - 17

SAFETY PRECAUTIONS

GENERAL SAFETY RULES FOR OPERATING MACHINERY

WARNING:

As with all machinery, there are certain hazards involved with their operation and use. Exercising respect and caution will considerably lessen the risk of personal injury. However, if normal safety precautions are overlooked or ignored, personal injury to the operator or damage to property, may result.

1. READ and BECOME FAMILIAR with the entire operating manual. Learn the machines' applications and limitations as well as the specific potential hazards peculiar to it.
2. EARTH ALL MACHINES. If the machine is equipped with three-pin plug, it should be plugged into a three-pin electrical socket. Never remove the earth pin.
3. ALWAYS ensure that ADEQUATE LIGHTING is available. A minimum intensity of 300 lux should be provided. Ensure that lighting is placed so that you will not be working in your own shadow.
4. CHECK for DAMAGE. Before using the machine, any damaged part, such as a guard etc., should be checked to ensure that it will operate properly, and perform its intended function. Check for alignment of moving parts, breakage of parts, mountings, and any other condition that may affect the machines' operation. Any damage should be properly repaired or the part replaced. If in doubt, DO NOT USE the machine. Consult your local dealer.
5. DISCONNECT the MACHINE from the power supply before servicing and when changing accessories such as blades, etc.
6. KEEP GUARDS in place and in working order.
7. ALWAYS WEAR SAFETY GOGGLES, manufactured to the latest European Safety Standards. Also use a face or dust mask if the cutting operation is dusty. Everyday eyeglasses do not have impact resistant lenses, they are NOT safety glasses.
8. KEEP WORK AREA CLEAN. Cluttered areas and benches invite accidents.
9. ALWAYS WEAR EAR PROTECTORS/DEFENDERS.
10. DON'T FORCE the machine. It will do a better and safer job at the rate for which it was designed.

11. REMOVE ADJUSTING KEYS AND WRENCHES. Form the habit of checking to see that keys and adjusting wrenches are removed from the machine before switching on.
12. DRUGS, ALCOHOL, MEDICATION. Do not operate machine while under the influence of drugs, alcohol or any medication.
13. USE RECOMMENDED ACCESSORIES. The use of improper accessories could be hazardous.
14. NEVER LEAVE MACHINE RUNNING UNATTENDED. Turn power OFF. Do not leave machine until it comes to a complete stop.
15. ALWAYS REMOVE PLUG from electrical outlet when adjusting, changing parts, or working on machine.
16. AVOID DANGEROUS ENVIRONMENT. Don't use power machines in damp or wet locations or expose them to rain. Keep your work area well illuminated. DO NOT USE in explosive atmosphere (around paint, flammable liquids etc.).
17. KEEP CHILDREN AWAY. All visitors should be kept a safe distance from the work area, especially whilst operating the unit.
19. MAINTAIN MACHINE IN TOP CONDITION. Keep tools sharp and clean for the best and safest performance. Follow maintenance instructions.
21. DON'T OVERREACH. Keep your proper footing and balance at all times. For best footing, wear rubber soled footwear. Keep floor clear of oil, scrap wood, etc.
22. WEAR PROPER APPAREL. Loose clothing or jewelry may get caught in moving parts. Wear protective hair covering to contain long hair.
23. MAKE WORKSHOP CHILDPROOF. Cover the saw adequately when not in use, to prevent children from damaging themselves by tampering with it.
24. NEVER STAND ON THE MACHINE. Serious injury could occur if the machine is tipped or if a cutting tool is accidentally contacted. Do not store materials above or near a machine, such that it is necessary to stand on the machine to reach them.
25. HANDLE WITH EXTREME CARE Whenever transporting or installing machinery, and always use a lifting tool.
26. AVOID ACCIDENTAL STARTING. Ensure the switch is OFF before plugging in to mains.
27. BE AWARE that accidents are caused by carelessness due to familiarity. ALWAYS concentrate on the job in hand, no matter how trivial it may seem.

ADDITIONAL SAFETY INSTRUCTIONS

for MITRE SAWS

1. Wear safety goggles as protection against flying wood chips and saw dust. In many cases, a full face shield is even better protection. A dust mask is also recommended to keep saw dust out of your lungs.
2. Use a solid wood workbench which will not move under load.
3. This saw is for indoor, domestic use only.
4. Clear the work table of all objects except the workpiece (tools, scraps, rulers etc.) before switching on the saw.
5. Keep your fingers well away from the blade.
6. Switch off the saw, and make sure the blade has come to a complete stop before clearing sawdust or off-cuts from the table.
7. Make sure there are no nails or foreign objects in the part of the workpiece to be sawn.
8. Set up the machine and make all adjustments with the power OFF, and disconnected from the supply.
9. DO NOT operate the machine with the guards removed. They must all be in place and securely fastened when performing any operation
10. Use ONLY approved replacement saw blades. Contact your local CLARKE dealer for advice. The use of inferior blades may increase the risk of injury.
11. DO NOT saw any material that does not have a flat surface on which to bear.
12. This machine is designed for cutting wood. DO NOT use for cutting metal, plastics or masonry.
13. Do Not force the blade, lower it gently into the work.
14. Ensure you have complete control of the Cutting Head at all times. When a cut is completed, return it to its uppermost position gently. DO NOT allow it to snap back heavily under spring pressure.
15. Always clamp the work to the table...DO NOT perform freehand operations.
16. Ensure that the portion of the workpiece being cut bears firmly against the back fence.
17. Provide adequate support for long workpieces.
18. Never use solvents for cleaning plastic parts as this could cause damage to the material. A soft damp cloth only is required.

ELECTRICAL CONNECTIONS

Connect the mains lead to a standard, 230 Volt (50Hz) electrical supply through an approved 13 amp BS 1363 plug, or a suitably fused isolator switch.

WARNING! THIS APPLIANCE IS DOUBLE INSULATED 

IMPORTANT: The wires in the mains lead are coloured in accordance with the following code:

Blue - Neutral
Brown - Live

As the colours of the flexible lead of this appliance may not correspond with the coloured markings identifying terminals in your plug proceed as follows:

Connect BROWN cord to terminal marked with "L" or coloured RED.
Connect BLUE cord to the terminal marked with "N" or coloured BLACK.

If this appliance is fitted with a plug which is moulded onto the electric cable (i.e. non-rewirable) please note:

1. The plug must be thrown away if it is cut from the electric cable. There is a danger of electric shock if it is subsequently inserted into a socket outlet.
2. Never use the plug without the fuse cover fitted.
3. Should you wish to replace a detachable fuse carrier, ensure that the correct replacement is used (as indicated by marking or colour code).
4. Replacement fuse covers can be obtained from your local dealer or most electrical stockists.

Fuse Rating

The fuse in the plug must be replaced with one of the same rating - **13amps** and this replacement must be ASTA approved to BS1362.

Cable Extension

If a cable extension is needed, it is essential to ensure that the size of the conductors is at least the same size as those of the power cable supplied.

PRINCIPAL PARTS OF THE SAW

Fig.1

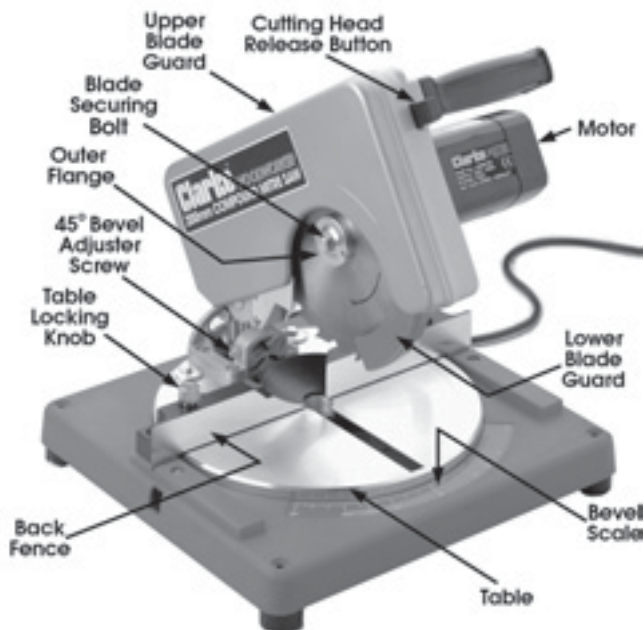
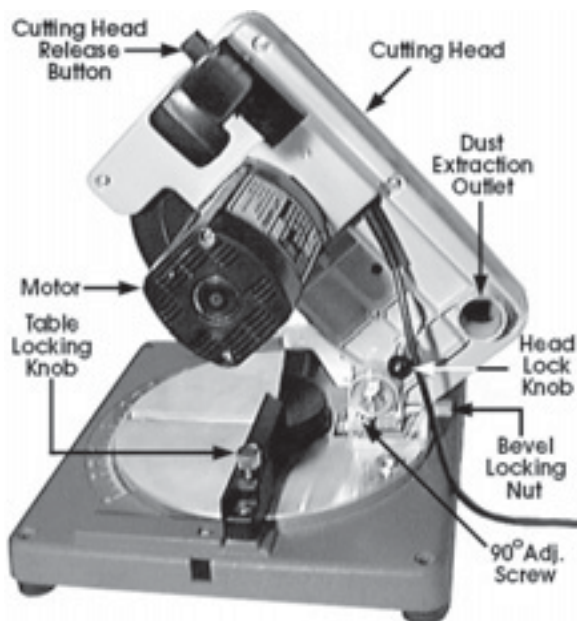

Fig.2



FEATURES (Ref. Fig. 3)

As its' name implies, the machine is a Bevel/Mitre Saw, capable of straight cross cutting, and cutting bevels and mitres, or a combination of the two.

The main arm, or Cutting Head, carries the motor and the tungsten carbide saw blade. It is allowed to swivel to produce mitre cuts and tilt to the left to produce bevel cuts.

The maximum sizes of wood that may be cut in any of these processes is given under Specifications on page 15.

A dust extraction outlet (E) is provided at the rear of the machine. If required it can be connected to a vacuum cleaner which will provide fast and efficient removal of sawdust. The vacuum cleaner may be used continuously or intermittently depending upon your requirements.

Saw blades with a bore of 18mm or 20mm may be used.

This saw is not designed for cutting metal, plastics or masonry.

Fig.3

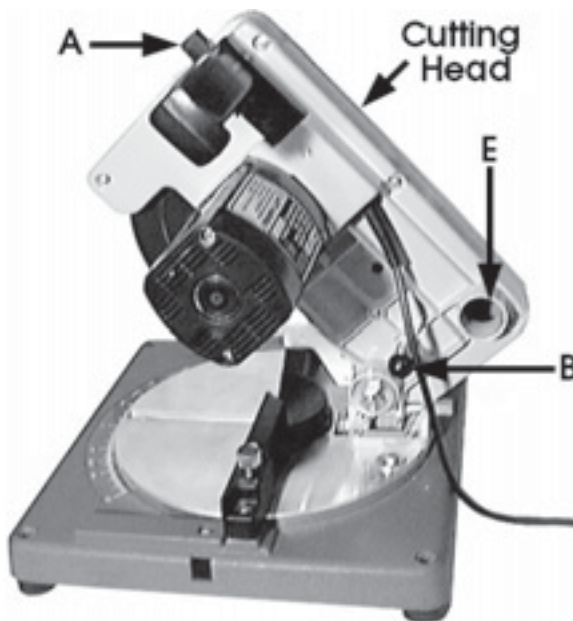

ASSEMBLY and INSTALLATION. Ref: Fig. 3

The saw is fully assembled and adjusted at the factory. On receipt inspect the machine to ensure that all parts are accounted for and that no damage was incurred during transit.

Loose items are: 1x Peg spanner, and 1x Box spanner

Any deficiency or damage should be reported to your CLARKE dealer immediately.

Mount the machine on a firm solid base that will not move under load. Ensure there is an appropriate electrical supply, and adequate lighting, so that you will not be working in your own shadow.

Four holes are provided, one at each corner of the base, so that the machine may be bolted permanently to a workbench for added stability, using 8mm bolts (not provided). Alternatively it may be bolted to a piece of plywood with a thickness of 16mm (5/8").

The Cutting Head is locked in its lower position for transit purposes. To release it, pull out the Head Locking Knob (B), (It may be necessary to apply slight downward pressure to the head in order to do so), and allow the head to rise to its upper position gently, under control.

The head will lock in its upper position, and is prevented from being lowered until the Head Release Button (A) is pressed

OPERATION. (Ref Fig.4)

A. Cross Cutting. (at 90°)

First, set the work in place with one end firmly clamped against the table and back fence.

It is important to ensure that one end of the workpiece is completely free to move i.e. NOT clamped or held in any way. This will normally be the off-cut or shorter end.

NOTE: If the workpiece is not entirely straight, ensure that the portion at either side of the intended cut rests firmly against the table and back fence.

When satisfied, make a final check to ensure that all safety precautions are being complied with, then pull and hold the starter switch (G, Fig.1), and allow the blade to reach full speed. If any unusual sounds or vibrations occur, release the starter switch immediately and investigate the cause.

When satisfied, press the Head Release Button (A), and gently lower the head so that the blade makes contact with the workpiece. Do not force the blade, a light pressure is all that is required.

You will notice that to provide maximum safety, the blade is not exposed at any time, and the guard rises automatically as the blade is lowered. Nevertheless, NEVER treat the machine with indifference, and NEVER be casual with your approach.

To switch off, release the starter switch whilst still maintaining full control of the head. NEVER allow the head to spring upwards - always maintain control. Wait for the blade to stop completely before removing the workpiece, off-cuts etc.



Fig.4

B. Mitre Cutting

This is a cross cutting operation, except that the saw blade is set at an angle to the work, but remains perpendicular to the table. This is achieved by mounting the complete Head assembly on a table which is free to rotate by up to 45° .

To set the required mitre angle unscrew the table securing screws (H, fig.5), and rotate the table, with the head and saw blade, to the desired position, lining up the angle on the scale with the mark on the edge of the table (J, fig.5). Lock the table in position with the locking screws (H).

The procedure for cutting is the same as that for cross cutting.



Fig.5

C. Straight Bevel Cutting

As with Mitre Cutting, this is a cross cutting operation, except that the blade is not perpendicular to the table, (see fig. 6).

Ensure the table is set so that the mark (J), on the edge of the table, lines up with the zero on the scale on the bed.

The 45° adjuster is factory set so that when the Head is tilted to its fullest extent the blade will cut a perfect 45° bevel.

If however you require any other angle, you should proceed as follows:

Cut a mitre of the required angle, on a spare piece of wood, and use this as a template for your bevel cut.

Fig.7

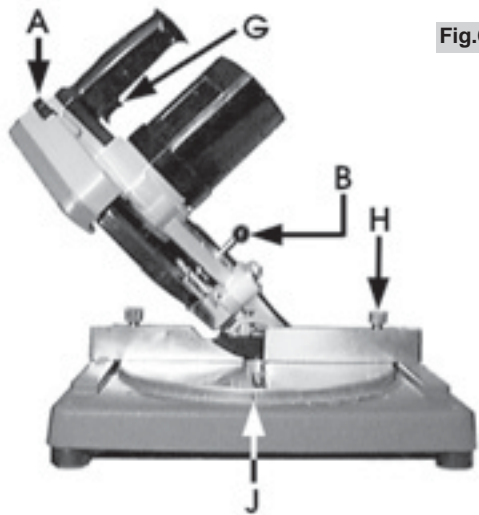

Fig.6

Slacken off the Bevel Locking Nut (C, fig.7), using the box spanner provided, and swing the Head to the side. Lower the arm, and bring your template up to the saw blade. When satisfied that the edge of template and blade are parallel, lock the head in position with lock nut (C). Your angle is now set.

The procedure for cutting is the same as that for cross cutting....press start

switch G, wait for full speed to develop, then lower the blade to the workpiece.

D. Compound Mitre and Bevel Cutting.

Having determined the angles you require, firstly set the bevel angle, using the procedure described above, and then the mitre angle.

NOTE: Compound mitre and bevel cuts, at a full 45°, can only be made when the head is turned to the left.

The procedure for cutting is the same as that for cross cutting.

MAINTENANCE

1. General

The machine is maintenance free, except for changing the saw blade when necessary, maintaining adjustments, and ensuring that after use, you clean away any sawdust or wood chips, with a low pressure air line or brush, paying particular attention to the motor air vents which should be kept clear at all times.

Should the motor not function normally, it is possible that it has become clogged with saw dust, in which case, it will be necessary to disassemble the motor in order to clean the various components. Contact your CLARKE dealer for advice.

2. Changing the Saw Blade

IMPORTANT: Exercise extreme care when handling the saw blade. The tips are extremely sharp, and careless handling could result in severe personal injury.

1. With the machine disconnected from the mains supply, and the cutting head in the raised position, slacken off the blade securing bolt.

This is achieved by holding the outer flange steady with the peg spanner provided, whilst turning the securing bolt (see fig. 8), **CLOCKWISE**. **The bolt has a LEFT HAND THREAD.**

Do not remove the bolt completely.

Fig.8



Fig.9

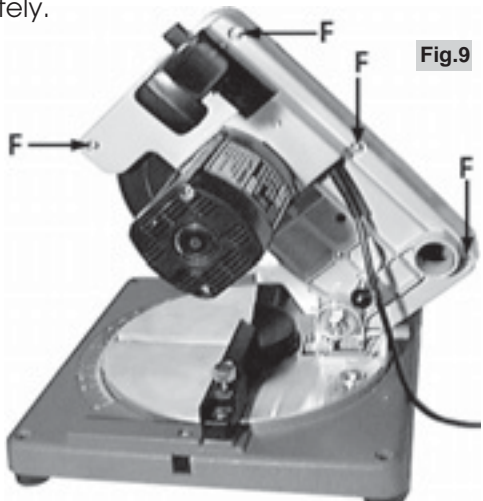

2. Remove the four bolts shown at F, Fig.9, and remove the Upper Blade Guard Cover.
3. With the cover removed, unscrew the blade securing bolt, with its washer, completely. Pull off the outer flange, and then the blade. (Take great care when handling the blade).

You should take this opportunity to clean the inside of the blade guard of any dust build-up and check generally for security of parts.

NOTE: This machine is capable of accepting blades with bores of 18 and 20mm.

Fig.10

4. Check the bore of your replacement blade. If it is the same as the blade you are replacing, simply mount it on to the boss of the inner flange shown in fig. 10, with the blade tips facing down at the front. Ensure the parts are perfectly clean, and the blade sits snugly on the boss.



5. Replace the outer flange followed by the securing bolt with washer - remembering the bolt has a **left hand thread**. Leave the bolt finger tight.
6. Replace the upper blade guard cover and securing bolts (F). Tighten the bolts, but do not overtighten them as this could strip the threads

NOTE:

If you are replacing a 18mm bore blade with an 20mm bore blade, or vice versa, it will be necessary to pull off the inner flange from the motor shaft, turn it through 180° and then replace it. The correct boss will now face outwards allowing you to properly mount the new blade.

7. With the upper blade guard cover secure, tighten the blade securing bolt using the peg and socket spanners and provided. Do not overtighten and DO NOT use extensions to the socket spanner lever.

NOTE: The use of HSS blades is NOT recommended.

ADJUSTMENTS

If you find that the cross cut is not entirely square, it will be necessary to adjust the head using the 90° adjuster screw shown in Fig. 2 on page 8.

To do this, place a small square on the table. Lower the arm, and bring the square up to the blade to test for accuracy.

Should any adjustment be required, slacken off the Bevel Locking Nut and the 90° adjuster screw securing nut, then screw the adjuster accordingly whilst holding the head firmly against the stop. Tighten the securing nut when the head is exactly perpendicular.

Similarly should the 45° stop require adjusting, use a 45° template up against the saw blade to set the adjuster to the correct position.

SPECIFICATIONS

Motor:	230V 50Hz 1 phase.
Running Current	5Amps
Power Rating:	800 Watts
Speed:	4500RPM
Fuse Rating	13Amps
Dimensions: (Head Lowered)	365x345x270mm
Dimensions: (Head Raised)	365x345x410mm
Blade size: (Fitted)	205mm 40T 18mm Bore
Noise level	109.7dB at 1M
Vibration Level	22.2m/s² (Normal Load)
Gross weight	7.2kg
Part Number	6500755

Maximum Cutting Sizes

Type of Cut	Depth	Thickness
Cross (90°)	50mm	100mm
Mitre (at 45°)	50mm	70mm
Bevel (at 45°)	35mm	100mm
Compound (at 2x 45°)	35mm	70mm

Please note that the details and specifications contained herein, are correct at the time of going to print. However, CLARKE International reserve the right to change specifications at any time without prior notice. Always consult the machine's data plate

PARTS DIAGRAM

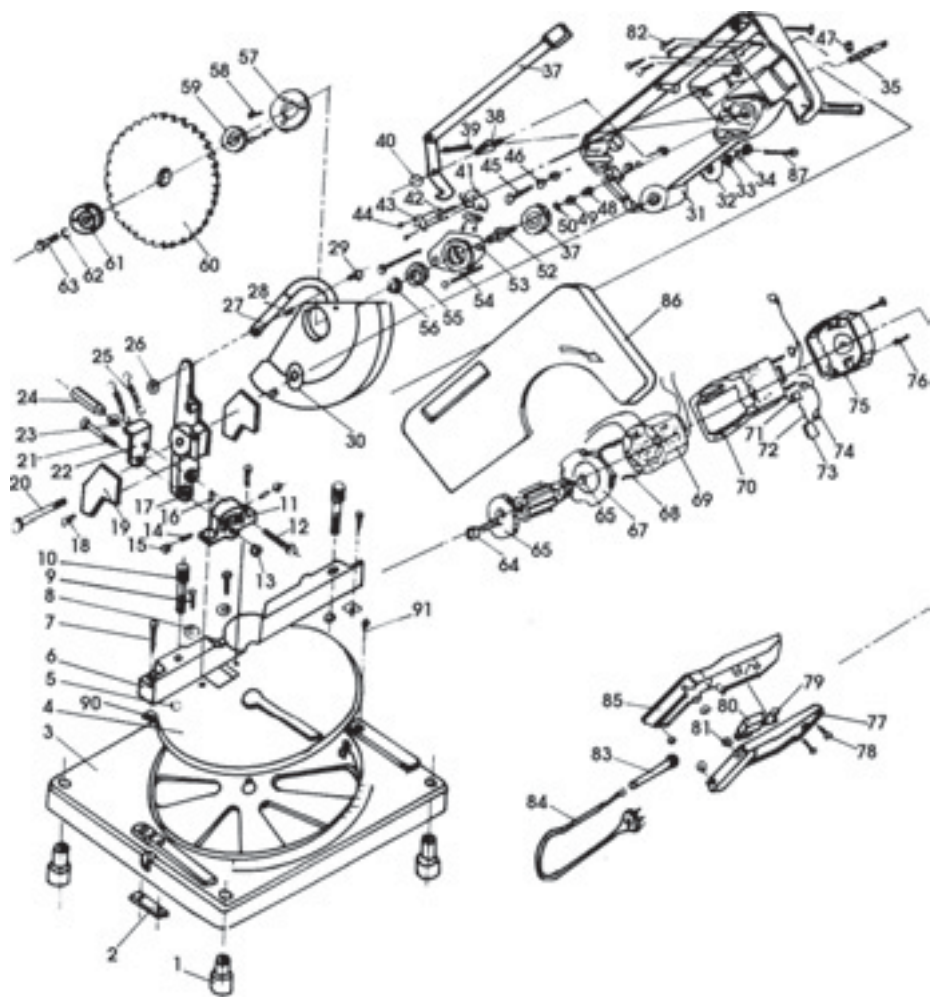

PARTS LIST

No.	Description	Part No.	No.	Description	Part No.
1	Foot	HTCMS20001	47	Nut, MS	HTCMS20047
2	Clamp	HTCMS20002	48	Bush, HK0709	HTCMS20048
3	Base	HTCMS20003	49	Washer	HTCMS20049
4	Turntable	HTCMS20004	50	Key	HTCMS20050
5	Washer	HTCMS20005	51	Gear	HTCMS20051
6	Backfence	HTCMS20006	52	Transmission shaft	HTCMS20052
7	Screw, M6X28	HTCMS20007	53	Ball bearing base	HTCMS20053
8	Eccentric spacer	HTCMS20008	54	Screw, M4X50	HTCMS20054
9	Screw, M6X16	HTCMS20009	55	Ball bearing	HTCMS20055
10	Screw	HTCMS20010	56	Precision washer	HTCMS20056
11	Support base	HTCMS20011	57	Cover	HTCMS20057
12	Screw, fixed	HTCMS20012	58	Screw, M4X8	HTCMS20058
13	Nut, M8	HTCMS20013	59	Inner Flange	HTCMS20059
14	Screw, M5X18	HTCMS20014	60	Saw Blade	HTCMS20060
15	Nut, M5	HTCMS20015	61	Outer Flange	HTCMS20061
16	Screw, M6X16	HTCMS20016	62	Spring washer	HTCMS20062
17	Roker arm	HTCMS20017	63	Bolt, M8X25	HTCMS20063
18	Guard	HTCMS20018	64	Ball bearing	HTCMS20064
19	Screw, M5X12	HTCMS20019	65	Armature	HTCMS20065
20	Main Pivot	HTCMS20020	66	Ball bearing	HTCMS20066
21	Bolt	HTCMS20021	67	Plate	HTCMS20067
22	Bracket	HTCMS20022	68	Screw, M4X58	HTCMS20068
23	Pressure sleeve	HTCMS20023	69	Stator assy.	HTCMS20069
24	Long nut	HTCMS20024	70	Casing	HTCMS20070
25	Spring	HTCMS20025	71	Brush	HTCMS20071
26	Nut, MS	HTCMS20026	72	Bush spring	HTCMS20072
27	Guard cover	HTCMS20027	73	Brush holder	HTCMS20073
28	Spring	HTCMS20028	74	Inducer	HTCMS20074
29	Positioning screw	HTCMS20029	75	Rear cover	HTCMS20075
30	Washer	HTCMS20030	76	Screw,	HTCMS20076
31	Frame	HTCMS20031	77	Handle LH	HTCMS20077
32	Washer	HTCMS20032	78	Screw, M4X18	HTCMS20078
33	Fixed washer	HTCMS20033	79	Capacitor	HTCMS20079
34	Nut,	HTCMS20034	80	Switch	HTCMS20080
35	Pin	HTCMS20035	81	Nut, MS	HTCMS20081
36	Washer	HTCMS20036	82	Screw, M5X11	HTCMS20082
37	Push rod	HTCMS20037	83	Cable shroud	HTCMS20083
38	Positioning bolt	HTCMS20038	84	Power cable	HTCMS20084
39	Spring	HTCMS20039	85	Handle RH	HTCMS20085
40	Washer	HTCMS20040	86	Cover	HTCMS20086
41	Cable support	HTCMS20041	87	Screw, M4X34	HTCMS20087
42	Screw, M5X12	HTCMS20042	88	Locking knob	HTCMS20088
43	Cord clamp	HTCMS20043	89	Frame	HTCMS20089
44	Screw, M4X12	HTCMS20044	90	Square washer	HTCMS20090
44	Bolt, M6X45	HTCMS20045	91	Screw, M6X12	HTCMS20091
46	Nut, M6	HTCMS20046			

Clarke[®]
INTERNATIONAL



DECLARATION OF CONFORMITY

We declare that this product complies to the following standards/directives:

- 89/392/EEC
- 91/368/EEC
- 93/44/EEC
- 93/68/EEC
- 89/336/EEC
- BS EN 61029-1

Product Description: **COMPOUND MITRE SAW**
Model Number: **CMS 200**
Serial (Batch) No: **See Front Page**

Signed

A handwritten signature in black ink, appearing to be 'L. E. Fry', is written over a horizontal line.

Clarke[®] INTERNATIONAL
Hemnal Street, Epping, Essex CM16 4LG