

ClarkeTM

PUMP



SUBMERSIBLE WATER PUMP

Model Nos. CSE400A

CE

0301

OPERATING & MAINTENANCE
INSTRUCTIONS

Thank you for purchasing this Clarke Submersible Pump.

This highly efficient pump is designed for pumping clean water only, please see Features, page 5), and are ideally suited for draining ponds, pools, building excavations etc, where water temperature does not **exceed 35°C**.

These pumps are NOT suitable for pumping salt water, or for permanent installation in fish ponds as the acidity, found in fish ponds, will damage the pump seals.

Before attempting to operate your pump, please read this instruction manual thoroughly and follow all directions carefully. This is for your own safety and that of others around you, and to help you achieve long and trouble free service from your pump.

GUARANTEE

This product is guaranteed against faults in manufacture for 12 months from purchase date. Keep your receipt as proof of purchase. This guarantee is invalid if the product has been abused or tampered with in any way, or not used for the purpose for which it is intended. The reason for return must be clearly stated. This guarantee does not affect your statutory rights.

Please note that dismantling this pump will invalidate the guarantee.

SAFETY PRECAUTIONS

1. These pumps are designed to pump **WATER ONLY**. **NEVER** use for pumping flammable liquids or chemicals of any kind.
2. **NEVER** run the pump dry.
3. An approved Residual Current Device (RCD) **MUST** be used when pumping from ponds or swimming pools.
4. Your submersible pump may **ONLY** be used for pumping water from a swimming pool when there is no person or animal in the pool.
5. **ALWAYS** disconnect the pump from the electrical supply before placing into, or removing from the water, and before any cleaning or maintenance of the pump.
6. **ALWAYS** use the handle, with a rope or chain attached when lifting the pump. **NEVER** lift the pump by the mains cable or the float switch cable.
7. **NEVER** run the pump with the body exposed for longer than 10 minutes.
8. **NEVER** install the pump on sand, silt, mud etc, or ground which is likely to shift.
9. If the water is likely to freeze, the pump **MUST** be run continuously, otherwise the pump must be removed from the water and stored in a frost free location.
10. If the pump is to be used where there may be silt or mud (e.g., garden ponds), keep the pump clear of any sediment by standing it on a platform or brick or suspending from a rope attached to the handle.



ELECTRICAL CONNECTIONS

Their mains lead should be connected to a standard 230Volt (50Hz) electrical supply through an approved plug or a suitably fused isolator switch. We strongly recommend that these pumps be fitted with a Residual Current Device (RCD).

NOTE: This is MANDATORY when pump is used for pumping swimming pools and ponds

If the pump is to be connected to an outdoor electrical supply, make sure that both the plug and the socket are of a BS approved waterproof design.

In the event that the pump is hard wired into the electrical system, it must be carried out in accordance with IEE regulations.

If used for draining swimming pools or ponds, the pump MUST be fitted with a Residual Current Device (RCD), with a rated residual operating current of no greater than 30mA.

WARNING: THIS APPLIANCE MUST BE EARTHED

IMPORTANT: The wires in the mains lead are coloured in accordance with the following code:

Green & Yellow	-	Earth
Blue	-	Neutral
Brown	-	Live

As the colours of the flexible cord of this appliance may not correspond with the coloured markings identifying terminals in your plug proceed as follows:

Connect GREEN & YELLOW cord to plug terminal marked with a letter "E" or Earth symbol "⏏" or coloured GREEN or GREEN & YELLOW.

Connect BROWN cord to terminal marked with a letter "L" or coloured RED

Connect BLUE cord to terminal marked with a letter "N" or coloured BLACK

FUSE RATING

The fuse in the plug for this appliance must be rated at **13 amps**.

If this appliance is fitted with a plug which is moulded onto the electric cable (i.e. non-rewirable) please note:

1. The plug must be thrown away if it is cut from the electric cable. There is a danger of electric shock if it is subsequently inserted into a socket outlet.
2. Never use the plug without the fuse cover fitted.
3. Should you wish to replace a detachable fuse carrier, ensure that the correct replacement is used (as indicated by marking or colour code).
4. Replacement fuse covers can be obtained from your local dealer or most electrical outlets
5. The fuse in the plug must be replaced with one of the same rating (**13 amps**) and this replacement must be ASTA approved to BS1362.

IMPORTANT:

If you are in any doubt regarding electrical installation, you should consult a qualified electrician.

FEATURES

This pump is of rugged and durable construction, designed for long lasting operation and its plastic body provides good anti corrosive properties. The motor is provided with built in overload protection.

For your information the chart, on page 9 shows the flow rate for the pump at various heads. HEAD is the distance, or height, from the surface of the water to the point of discharge)

This pump is designed to pump clean water such as fish ponds, swimming pools, flooded cellars etc.

IMPORTANT:

The Pump is NOT designed for pumping slurry, sludge, mud or heavily polluted water, and should NOT be used for PERMANENT INSTALLATION in fish ponds or any water containing chemicals or other acidic contaminants including salt water.

Whenever the pump is used to pump contaminated water, e.g. to drain fish ponds etc., you must ALWAYS immerse it in clean water and run it for a few minutes on completion, to ensure it is completely cleansed of all contaminants.

The maximum depth to which this pump should be submerged is 8 Metres.

This pump is suitable for permanent or semi-permanent installations, e.g. installations where it is necessary to maintain a water at a particular level.

As the water level rises, so will the float. At a certain point the switch will operate and start the pump. As the water level falls, so will the float until the switch operates again and stops the pump.

You can adjust the level at which the pump cuts out by sliding the float switch cable through the slots in the handle.

Shorten or lengthen it as required. The shorter it is, the earlier the pump will cut out, and the water therefore will be deeper at this point. Similarly, it will cut in earlier and the water will therefore be shallower when it does so.

ALWAYS check its operation before use.

Theoretically, the pump will drain a sump down to a depth of 5mm, but this will depend upon the float switch setting.

You should never allow the pump to operate for longer than 10 minutes with the pump body exposed....that is....when the water level is below 70mm.

The pump is provided with a vent valve in order to prevent an air lock when plunging the pump into the water. It may take up to 1 minute before all air is expelled, once the pump is submerged.

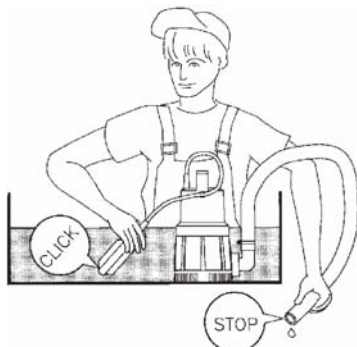

INSTALLATION and OPERATION

The pump is complete with an Outlet Hose Adapter which simply screws into the outlet port on the side of the pump body.

The adapter has three steps, providing the option for three different hose sizes to be used. (See specifications for details).

Please bear in mind, that if the pump is to be used for drainage purposes, or in situations that demand maximum efficiency, you should ALWAYS connect the **largest diameter hose possible** to the outlet hose adapter, as small diameter hoses reduce capacity and put additional strain on the motor.

Once you have decided upon a suitable hose size, the smaller diameter steps of the adapter should be cut off, so as not to cause an obstruction to flow. If you subsequently need to install a larger diameter hose, replacement adapters are available from your Clarke dealer.

Ensure the hose is secured with a suitable worm drive clip (not supplied).

The pump is completely submersible and must be placed in a vertical position on a solid flat surface. If this is not available, sit the pump on house bricks, or something similar, and ensure that this type of support is not likely to shift.

The pump should be well clear of silt, mud or any type of marine growth.

IMPORTANT:

ALWAYS raise and lower the pump using a rope attached to the handle,
NEVER by the power cable or float switch cable.

Ideally the pump should be placed in a sump which has adequate dimensions so as not to restrict the movement of the float switch.

Please note that the symbol ∇ on the pumps' Rating Plate, denotes the **MAXIMUM** depth to which the pump may be submerged, in metres.

With the pump properly installed, and taking all necessary precautions as described on page 3, plug in to the mains supply, and switch ON.

Note:

If the pump does not deliver immediately, it is possible that an air lock exists. Leave the pump for approximately one minute in order for air in the pump to vent through the vent valve. If necessary, switch ON and Off again in order to assist the venting process.

**SUITABLE HOSE, and SPARE/REPLACEMENT HOSE ADAPTERS ARE AVAILABLE
FROM YOUR CLARKE DEALER**

MAINTENANCE

WARNING

Before checking the condition of the pump, ensure it is unplugged from the mains supply. If the unit is hard wired, ensure the circuit breaker is open.

Check the pump installation regularly to ensure the base inlet is clear of leaves or other debris.

Note that the pump is fitted with an automatic thermal overload protection device. If the pump overheats due to an obstruction in the pump, or pumping warm water in excess of 35°C for example, it will shut off automatically. Switch the pump OFF and disconnect from the mains supply. Check for blockages and allow the motor to cool (at least 15 minutes) before attempting to restart.

The pump should require no maintenance other than regular cleaning. If it starts to show signs of wear or damage, contact your CLARKE dealer for advice. Do not use the pump if there is any damage to the mains supply cable, or to the float switch or its cable.

DO NOT ATTEMPT TO REPAIR THE PUMP YOURSELF, as you may damage the waterproof seal and invalidate your guarantee. Repairs must be carried out by your CLARKE dealer, or contact the CLARKE Service Department, on **0208 8988 7440**.

If the pump becomes badly clogged, back flush by removing the outlet hose adapter and directing a jet of clean water through the outlet port.

TROUBLE SHOOTING

A. PUMP WILL NOT START

1. Float switch may be jammed against side wall, or prevented from moving.
2. Water level too low - float switch in OFF position - Lift float to check switch.

B. PUMP WILL START BUT NOT DELIVER

1. Check to ensure strainer is not blocked.
2. Discharge tube clogged or obstructed.
3. The head may be too great, i.e. you are trying to lift the water too great a distance for the pump to cope with. (See specifications pages 9 -10).
4. Impeller may be damaged - Consult your CLARKE dealer
5. Air lock in system. Switch OFF and ON again to deaerate the system

C. PUMP WILL NOT STOP

1. Float switch may be prevented from moving to the fully down position.
2. Float switch may be faulty. Consult your CLARKE dealer for advice.

D. PUMP STOPS RUNNING

1. Thermal overload has operated. If this condition persists, investigate the cause. Are you attempting to pump liquid which is too heavy for the pump (mud, slurry etc.) or a foreign object has jammed the impeller.
2. Float switch has cut in.
3. No electrical supply....investigate cause. i.e.check fuse/RCD/Circuit breaker etc.

SPECIFICATIONS

Supply Voltage	230V 50Hz 1Ph
Fuse Rating	13 Amps
Outlet Dia.	1 1/4" BSP
Outlet Hose Adapter Dia. 1	1"/25mm
2	3/4"/19mm
3	1/2"/13mm
Motor Output	400 Watts
Head Max.	8M
Max. Submersion Depth	8M
Max. Capacity (at zero head)	7M ³ /hr(115L/min)
Max. Pressure	0.8 bar
Weight (net)	4.3 kg
Cable	10M (H05RN-F)
Dimensions	305 x155mm**
Part No.	7231100

**Diameter x Height...not including outlet

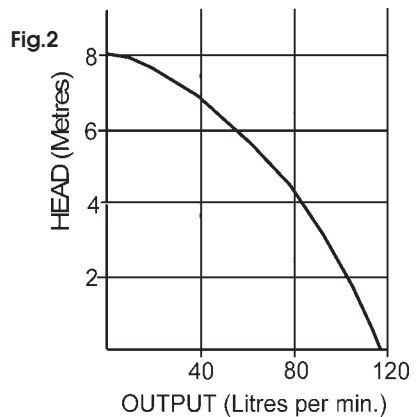
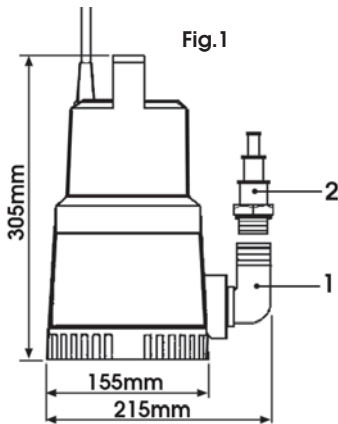

SPARE PARTS

Replacement parts are shown in Fig.1. Elbow (1) and 3-stage Adapter (2).
Please consult your local Clarke dealer or Clarke International Spare Parts Department

For Spare Parts or Service, please contact your Clarke dealer, or Clarke International as follows:

PARTS & SERVICE TEL: 020 8988 7400
PARTS & SERVICE FAX: 020 8558 3622
 or e-mail as follows:
PARTS: Parts@clarkeinternational.com
SERVICE: Service@clarkeinternational.com