

Clarke[®] *PUMP*



CPE RANGE PUMPS

MODEL NO: CPE15S/T-20S/T-30S/T

PART No: 7120203/4-7120205/6-7120207/8

OPERATION & MAINTENANCE INSTRUCTIONS



Contents

Specifications	2
Guarantee :	3
Safety Precautions	4
Water Connections	5
Electrical Connection :	6
Maintenance :	7
Trouble Shooting	7
Parts (CPE15) :	9 & 10
Parts (CPE20) :	11 & 12
Parts (CPE30) :	13 & 14

We declare that this product complies with the 73/23/EEC directive.

A handwritten signature in black ink, appearing to be 'L. S. Fy', written over a horizontal line.

Please note that the details and specifications contained herein are correct at the time of going to print. However CLARKE International reserve the right to change specifications at any time without prior notice. Always consult the machines data plate

Specifications

MODEL	SIZE INCHES	MOTOR HP	VOLTS/PH	MAX FLOW LPM	MAX HEAD M	WEIGHT KG	PART No
CPE15S	1½"	1	230/1	325	17	14.0	7120203
CPE15T	1½"	1	400/3	325	17	14.0	7120204

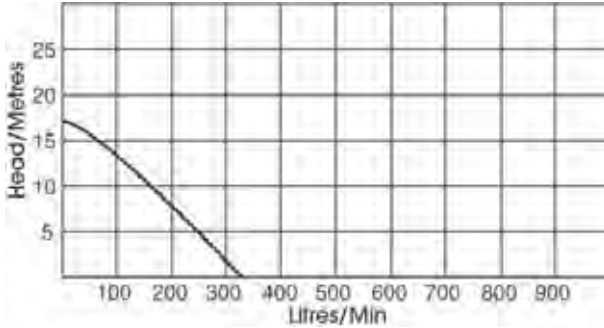

CPE20S	2"	2	230/1	500	17	14.5	7120205
CPE20T	2"	2	400/3	500	17	14.5	7120206

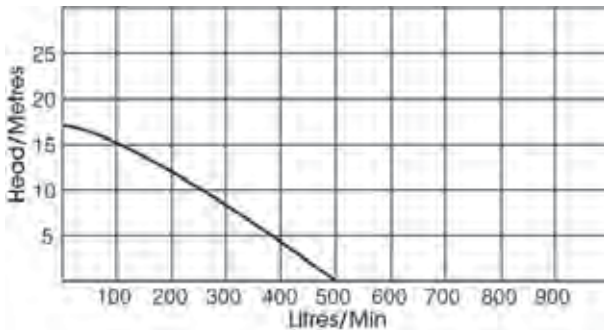

CPE30S	3"	3	230/1	800	18	15.5	7120207
CPE30T	3"	3	400/3	800	18	15.5	7120208

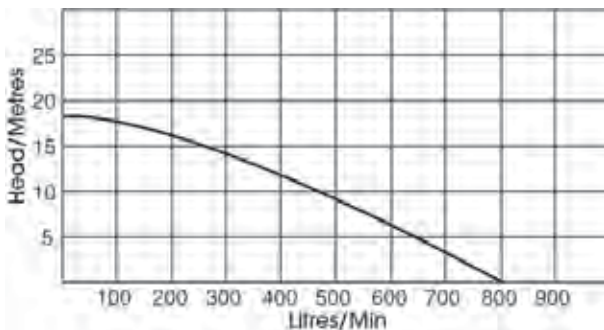



Please read these instructions carefully before operating the Pump

Thank you for purchasing this **CLARKE** Pump
Before using the device, please read this manual thoroughly and carefully follow all instructions given. This is for your own safety and that of others around you, and is also to help you achieve long and trouble free service from your new tool.

CLARKE GUARANTEE

This CLARKE product is guaranteed against faulty manufacture for a period of 12 months from the date of purchase. Please keep your receipt as proof of purchase.

This guarantee is invalid if the product is found to have been abused or tampered with in any way, or not used for the purpose for which it was intended.

Faulty goods should be returned to their place of purchase, no product can be returned to us without prior permission.

This guarantee does not affect your statutory rights.

Your CLARKE CPE PUMP is a highly efficient, robust, continuously rated, self priming pump with a powerful electric motor, and is ideal for a wide range of domestic, commercial and agricultural uses.

It is suitable for pumping clean tap and rain water, and will handle small solids in suspension. Your CLARKE CPE PUMP is designed to give you trouble free service provided it is installed and used in the correct way.

Please follow these instructions carefully.



WARNING



**CPE RANGE PUMPS ARE NOT SUBMERSIBLE PUMPS.
ON NO ACCOUNT MUST THEY BE IMMERSED IN WATER.**

If the pump is left in an exposed position, it should be protected from the elements. especially frost.

All electrical connections should be inspected regularly for signs of corrosion and cleaned where necessary. It is advisable to apply a film of silicon grease on the terminals for added protection.

Safety Precautions



As with all machinery, there are certain hazards involved with their operation and use. Exercising respect and caution will considerably lessen the risk of personal injury. However, if normal safety precautions are overlooked or ignored, personal injury to the operator even damage to the pump or property, may result. For your own safety and that of others around you, please read these safety instructions in conjunction with the operating instructions, and before using the pump.

- These pumps are designed to pump **Water Only**. **NEVER** use for pumping flammable liquids or chemicals of any kind.
- **ALWAYS** ensure the pump is installed in a horizontal position with the outlet facing vertically upwards, and that it is firmly anchored via its fixing screws.
- **ALWAYS** ensure there is an adequate air flow around the pump. **DO NOT** mount it in an enclosed atmosphere.
- **ALWAYS** ensure all water pipes - supply or discharge, are adequately supported where necessary, so as not to put a strain on the pump connections.
- **ALWAYS** ensure the inlet to the pump is completely unrestricted.
- **ALWAYS** ensure the pump is protected from the elements, neither the motor nor the electrical terminal box is intended to be waterproof.
- **ALWAYS** ensure that all pipes are protected against damage where necessary, and that they are suitably lagged to avoid the possibility of freezing during cold weather.
- **ALWAYS** disconnect the pump from the electrical supply before any cleaning or maintenance of the pump.
- **NEVER** allow the pump to run dry, as this will cause serious damage to the pump seals.
- **NEVER** switch the pump ON when a swimming pool etc, is in use, i.e., when there is person or animal in the pool.

Water Connections

IMPORTANT: The pump **MUST NOT** be connected to the mains supply until all hose/pipe installation is completed. **DO NOT RUN THE PUMP DRY**

NOTE: If any part of the system is to be connected to the mains water supply, ensure that local water authority regulations are observed.

Because of the variety of possible installations, no plumbing accessories are supplied with your pump, however accessories designed specifically for this range of pumps is available from your nearest CLARKE dealer.

The pump must always be installed and operated in an upright position i.e. with the outlet port facing vertically upwards. The fixing holes in the base should be used as necessary to secure the pump firmly in its operating position. Also ensure there is adequate air circulation around the motor.

Avoid situations where there is a risk of water coming into contact with the outside of the pump. Neither the motor or the terminal box are designed to be waterproof.

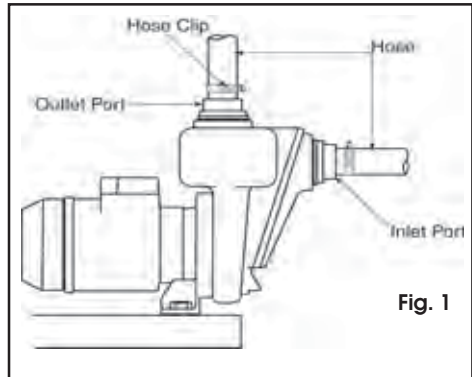

These notes are for guidance on how to achieve a proper working system. The diagram (Fig. 1) above shows a typical installation at the pump.

A foot valve and filter should be fitted to the lower end of the suction hose, as illustrated in Fig. 2, so as to retain water in the suction system and more importantly, to prevent the possibility of large foreign objects entering the pump body.

The performance of your pump will be affected by the diameter of the inlet pipe - any restriction will greatly reduce the flow. We strongly recommend that you use a pipe diameter as large as practicable.

A gate valve may be installed in-line on the delivery side (Outlet Port) of the pump which can be adjusted as required to regulate the flow of water, it can also assist in priming the pump.

WARNING DO NOT place any such obstruction on the suction side (Inlet Port) of the pump unless it is an isolator valve in a gravity fed system. It is also **IMPORTANT** to note, that these pumps should not be operated with the delivery valve completely closed.

To prevent unnecessary strain or possible distortion to the pump, ensure that adequate support is provided to the hoses and or pipes. They will be considerably heavier when filled with water.

Should foreign contaminants come into contact with the pump, flush through with cold water as soon as possible to prevent damage to the pump.

Protect the pump and pipework from freezing. The formation of ice may cause serious damage.

Where the pump is to be a permanent fixture, the fittings to the pump **MUST be** flexible, i.e. a short piece of hose should be inserted between the rigid pipework and the pump.

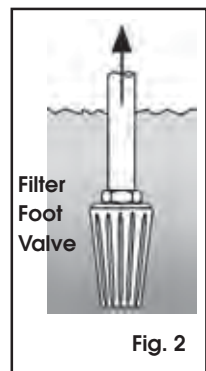

Electrical Connection



WARNING: THIS PUMP MUST BE EARTHED.



Before connecting the pump, check the voltage and phase supply required, this information can be found on the junction box cover on top of the motor.

Installation should be carried out by a qualified electrician, using I.E.E approved cable and fittings, and in accordance with I.E.E. Regulations. However, in the further interests of safety we would emphasise the following,

Wiring Connections For Single Phase Models

Single phase pumps should be connected to a standard domestic 13 amp, 230 volt (50Hz), electrical supply, we strongly recommend that the connection be made via a suitable isolator switch and Residual Current Device (RCD).

IMPORTANT: Should the supply be taken from a normal 13 amp socket, then the plug used must be to BS 1363 standard, and the wires should be wired up in accordance with the following colour code:

- Green & Yellow Earth or marked with a letter "E" or Earth symbol "⏚"
- Blue Neutral or terminal marked with a letter "N"
- Brown Live or terminal marked with a letter "L"

Connections Inside Terminal Box

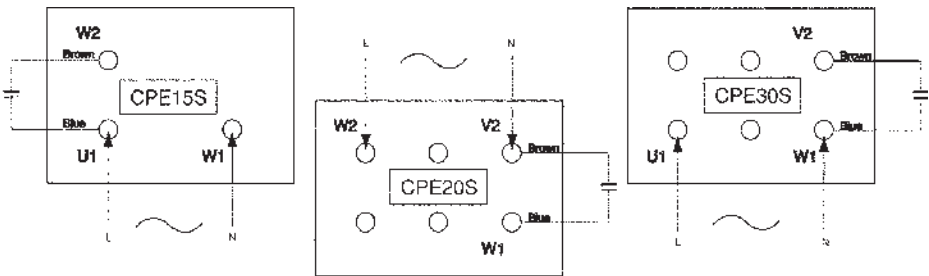

Wiring Connections For Three Phase Models

Again installation should be carried out by a qualified electrician, using I.E.E cable and fittings, and in accordance with I.E.E Regulations. To connect the cable to the motor see electrical connections inside the terminal cover.

Delta Connection

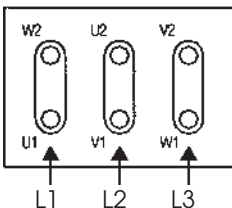

Star Connection

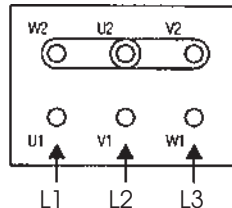

IF IN ANY DOUBT, contact CLARKE International Service on 020 8988 7400

Maintenance

No regular maintenance is required other than regular inspection to ensure that leaves and other particles are not covering the suction inlet, also check the pump for signs of wear or damage.

If any signs of wear or damage are found, contact your nearest Clarke dealer.

If you suspect that your pump is blocked by mud, silt, leaves etc, disconnect from the mains supply and backflush. This should dislodge any blockage and aid cleaning.

Trouble Shooting

there is little likelihood of problems arising, but if water will not flow as it should then check the following points:-

The pump does not run	<ol style="list-style-type: none">1. No mains supply2. Impeller seized / blocked	<ol style="list-style-type: none">1. Check fuse - replace if necessary (Check fuse rating).2. Disconnect pump from mains, investigate cause and clear blockage etc..
Pump runs but no output	<ol style="list-style-type: none">1. Air in pump housing2. Suction height too great	<ol style="list-style-type: none">1. Disconnect from the mains and check all hose connections are air tight etc.2. Check height is within spec. for your pump, (see specs page 2).
Low or no Flow	<ol style="list-style-type: none">1. Blocked inlet pipe2. Head too high	<ol style="list-style-type: none">1. Check to see that no foreign matter is fouling the intake system and check the filter is not blocked or obstructed.2. Check that head is within spec.

Should you still experience problems, then contact your Clarke dealer, or CLARKE International Service Department for advice.

PARTS & SERVICE TEL: 020 8988 7400

or e-mail as follows:

PARTS: Parts@clarkeinternational.com

SERVICE: Service@clarkeinternational.com

PARTS DIAGRAM (CPE15)

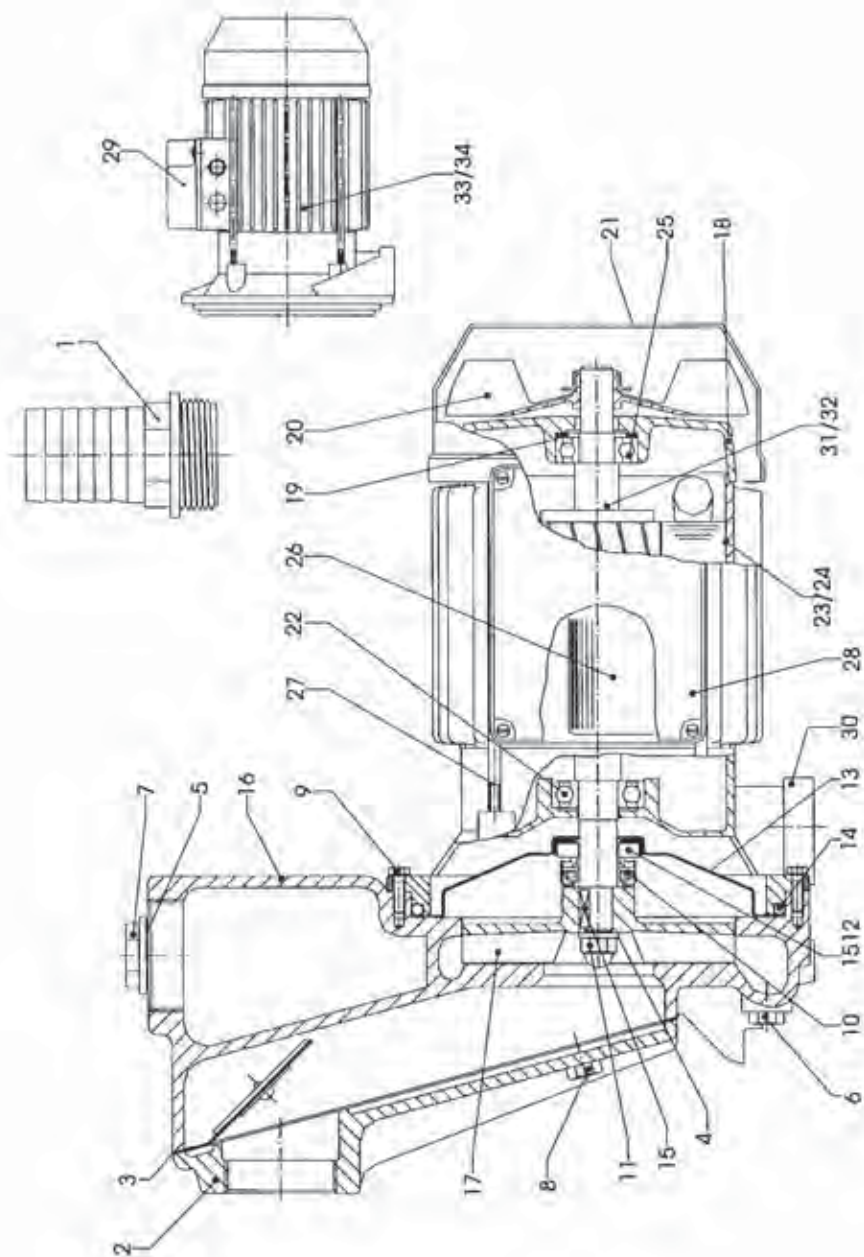

PARTS LIST (CPE15)

	Index No	Part No	Description	Qty
Pump	1	GM1076	Connection 1½" x 40	1
	2	GM5853	Valve Body	1
	3	GM6010	Check Valve	1
	4	GM6162	Washer	1
	5	GM6186	Flexolite Washer	1
	6	GM6209	Tap ¼"	1
	7	GM6213	Tap 1"	1
	8	GM6230	Screw	6
	9	GM6268	Screw	8
	10	GM6334	Mechanical Seal	1
	11	GM7103	Nut	1
	12	GM7702	Counterface	1
	13	GM7776	Cover Disk	1
	14	GM8048	'O' Ring	1
	15	GMF156	Key 4x4x16	1
	16	GMF458	Pump Body	1
	17	GMF501	Impeller	1
Motor	18	GM5114	Rear motor Cover	1
	19	GM5119	Elastic Washer	1
	20	GM5293	Fan	1
	21	GM5319	Fan Cover	1
	22	GM5375	Bearing	1
	23	GM5387	Motor Stator For CPE 15 A1 (1HP)	1
	24	GM5493	Motor Stator For CPE 15 A3 (3HP)	1
	25	GM5513	Bearing	1
	26	GM6581	Condenser 20 For CPE 15 A1	1
	27	GM6764	Vis	4
	28	GM6963	Condenser Box For CPE 15 A1	1
	29	GM7259	junction Box Cover For CPE 15 A3	1
	30	GM7700	Motor Bracket	1
	31	GM8640	Motor Shaft For CPE 15 A1	1
	32	GM8641	Motor Shaft For CPE 15 A3	1
	33	GMF313	Motor (1PH)	1
	34	GMF490	Motor (3PH)	1

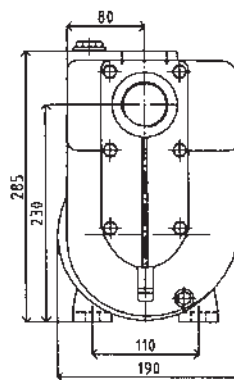
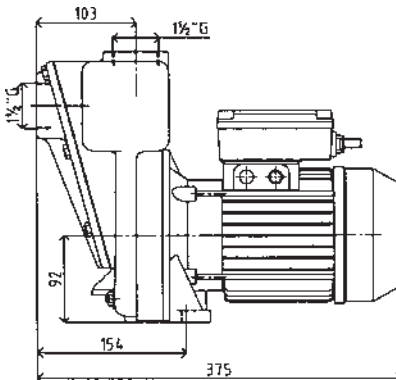

PARTS DIAGRAM (CPE20)

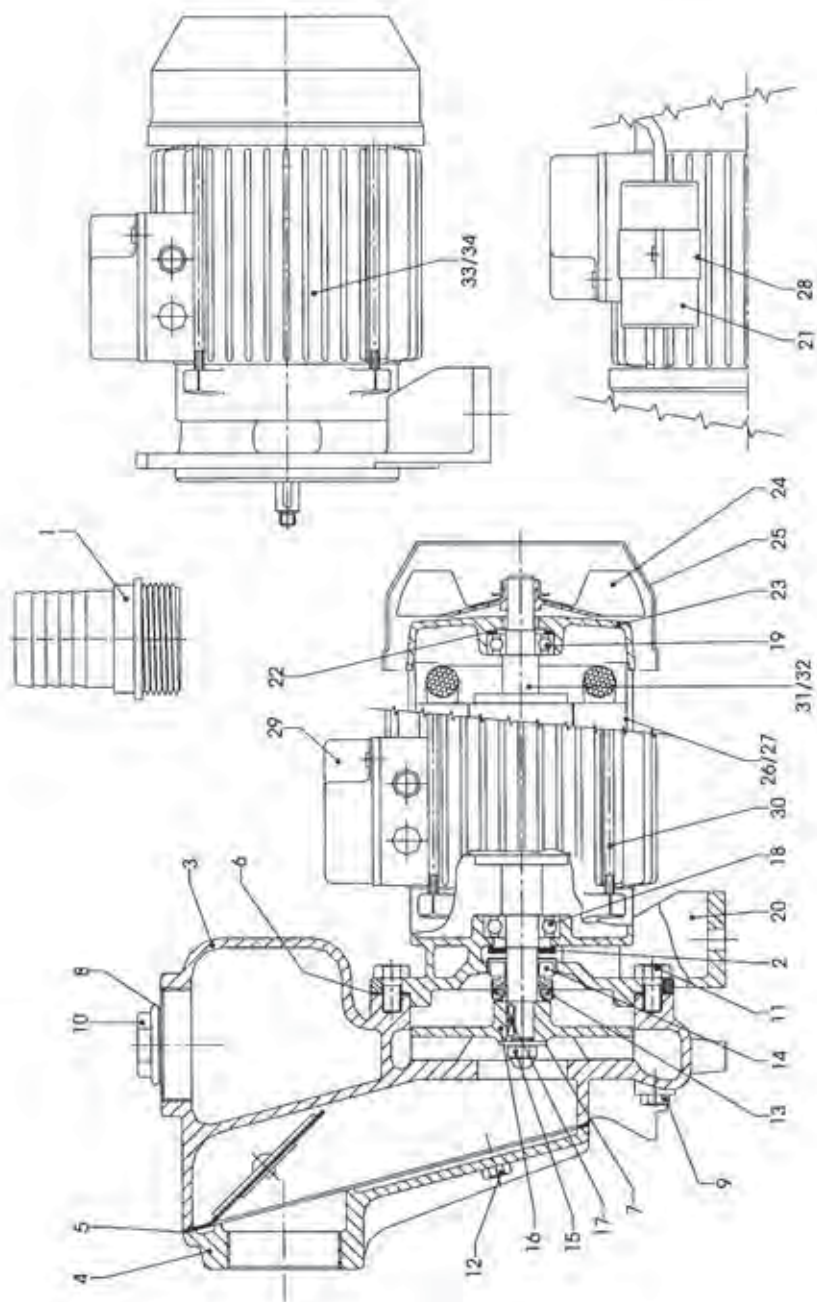

PARTS LIST (CPE20)

	Index No	Part No	Description	Qty
Pump	1	GM1010	Connection 2" x 50	2
	2	GM5342	Washer	1
	3	GM5571	Pump Body	1
	4	GM5854	Valve Body	1
	5	GM6012	Check Valve	1
	6	GM6029	Flexolite Gasket	1
	7	GM6162	Washer	1
	8	GM6186	Flexolite Washer	1
	9	GM6209	Tap 1/4"	1
	10	GM6213	Tap 1"	1
	11	GM6235	Screw	4
	12	GM6236	Screw	6
	13	GM6334	Mechanical Seal	1
	14	GM6346	Counterface	1
	15	GM7103	Nut	1
	16	GM8612	Impeller	1
	17	GMF156	Key 4x4x16	1
Motor	18	GM5465	Bearing	1
	19	GM5466	Bearing	1
	20	GM5503	Motor Bracket	1
	21	GM6994	Condenser 30 For CPE 20 A1	1
	22	GM6996	Elastic Washer	1
	23	GM6997	Rear Motor Cover	1
	24	GM6998	Fan	1
	25	GM6999	Fan Cover	1
	26	GM7168	Motor Stator For CPE 20 A1 (1HP)	1
	27	GM7176	Motor Stator For CPE 20 A3 (3HP)	1
	28	GM8002	Condenser Clip	1
	29	GM8018	junction Box Cover	1
	30	GM8084	Screw	4
	31	GM8643	Motor Shaft For CPE 20 A1	1
	32	GM8650	Motor Shaft For CPE 20 A3	1
		33	GM8657	Motor (1PH)
	34	GM8658	Motor (3PH)	1

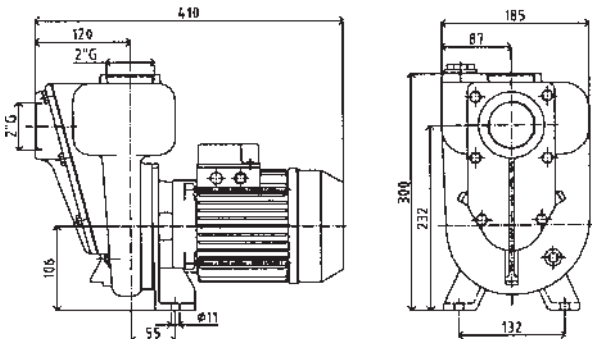

PARTS DIAGRAM (CPE30)

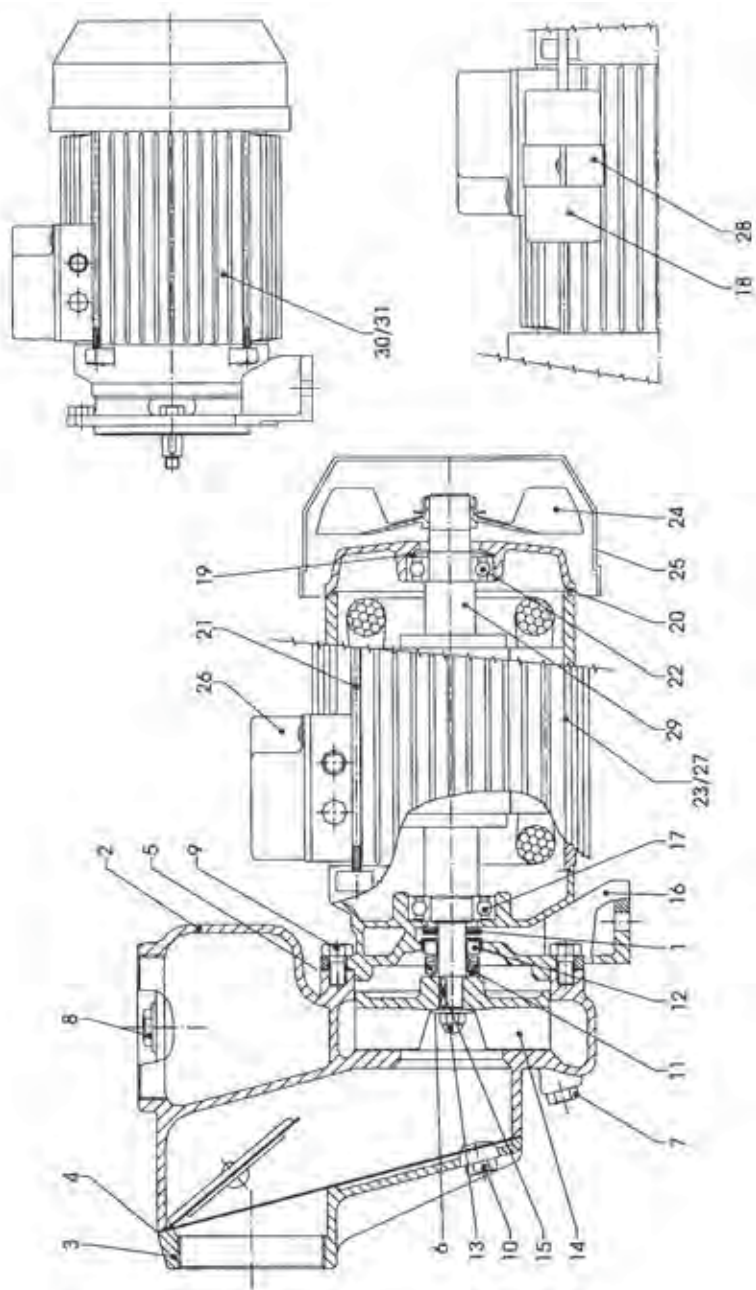

PARTS LIST (CPE30)

	Index No	Part No	Description	Qty
Pump	1	GM5342	Washer	1
	2	GM5574	Pump Body	1
	3	GM5857	Valve Body	1
	4	GM6013	Check Valve	1
	5	GM6029	Flexolite Gasket	1
	6	GM6162	Washer	1
	7	GM6209	Tap ¼"	1
	8	GM6211	Tap 1"	1
	9	GM6235	Screw	4
	10	GM6261	Screw	6
	11	GM6334	Mechanical Seal	1
	12	GM6346	Counterface	1
	13	GM7103	Nut	1
	14	GM8613	Impeller	1
	15	GMF156	Key 4x4x16	1
Motor	16	GM5505	Motor Bracket	1
	17	GM6321	Bearing	1
	18	GM6854	Condenser 50 For CPE 30 A1	1
	19	GM7187	Elastic washer	1
	20	GM8010	Rear Motor Cover	1
	21	GM8011	Vis	4
	22	GM8013	Bearing	1
	23	GM8014	Motor Stator For CPE 30 A1 (1 HP)	1
	24	GM8016	Fan	1
	25	GM8017	Fan Cover	1
	26	GM8018	Junction Box Cover	1
	27	GM8052	Motor stator For CPE 30 A3 (1PH)	1
	28	GM8286	Condenser Clip	1
	29	GM8652	Motor Shaft	1
	30	GM8659	Motor (1PH)	1
	31	GM8660	Motor (3PH)	1

