

# ClearFlo® PUMP



Model Nos

**CBM100SS, 130SS, 250SS, 240 & 240E  
CPE100P, 100TF, 120 & 130SS  
HANDY PUMP 2**

OPERATING & MAINTENANCE  
INSTRUCTIONS



© 0406



## CONTENTS

Safety Precautions .....	3
Electrical Connections .....	4
Water Connections .....	5
Priming the Pump .....	7
Troubleshooting .....	8
Specifications .....	9 -11
Parts Lists and Diagrams .....	12 - 29
Accessories .....	30
Parts and Service Contacts .....	30

## PARTS LIST & DIAGRAM REFERENCE

<b>Model No.</b>	<b>Page No.</b>
CPE100P .....	12 - 13
CPE100TF .....	14 - 15
CPE130SS .....	16 - 17
CPE120 .....	18 - 19
CBM240 .....	20 - 21
CBM240E .....	22 - 23
HANDY PUMP 2 .....	24 - 25
CBM100SS & CBM130SS .....	26 - 27
CBM250SS .....	28 - 29

Please note that the details and specifications contained herein, are correct at the time of going to print. However, CLARKE International reserve the right to change specifications at any time without prior notice.

When disposing of this product, ensure it is disposed of according to all local ordinances.

© Copyright CLARKE International. All rights reserved. February, 1998



Thank you for purchasing this CLARKE Water Pump, which is a general purpose pump, suitable for a variety of applications involving the transfer of clean, cold water ONLY (up to a maximum of 35°C) - for domestic and gardening applications. This manual covers a range of pumps as shown on the front cover. Please read it thoroughly and ensure you are familiar with all aspects relating to your particular pump, before its' connection and use. This will ensure the safe and proper installation of the pump, and assist it in providing a long, trouble free performance.

## GUARANTEE

This CLARKE product is guaranteed against faulty manufacture for a period of 12 months from the date of purchase. Please keep your receipt as proof of purchase. This guarantee is invalid if the product is found to have been abused or tampered with in any way, or not used for the purpose for which it was intended.

Faulty goods should be returned to their place of purchase. No product can be returned to us without prior permission. This guarantee does not effect your statutory rights.

## SAFETY PRECAUTIONS

1. Ensure the pump is installed in a horizontal position with the outlet facing vertically upwards, and except for the portable Handy Pump, it should be firmly anchored via its fixing screws.
2. Ensure there is an adequate air flow around the pump. DO NOT mount it in an enclosed atmosphere.
3. Ensure all water pipes - supply or discharge - are adequately supported where necessary, so as not to put a strain on the pump connections.
4. DO NOT allow the pump to run dry, as this will cause serious damage to the pump seals.
5. Ensure the inlet to the pump is completely unrestricted.
6. Ensure the pump is protected from the elements, neither the motor nor the electrical terminal box is intended to be waterproof.
7. Ensure that all pipes are protected against damage where necessary, and that they are suitably lagged to avoid the possibility of freezing during cold weather.

## ELECTRICAL CONNECTIONS

### WARNING

**THIS EQUIPMENT MUST BE EARTHED**

This appliance, which is provided with a 3-pin BS 1363 plug, should be connected to a standard domestic 13 amp, 230 volt (50Hz), electrical supply and we strongly recommend that this be done through a Residual Current Device (RCD).

Should the plug require renewing at any time, the wires should be connected in accordance with the following colour code:

- Green & Yellow ..... Earth or marked with a letter "E" or Earth symbol "⏚"
- Blue ..... Neutral or terminal marked with a letter "N"
- Brown ..... Live or terminal marked with a letter "L"

### FUSE RATING

The fuse in the plug must be replaced with one of the same rating (13 amps) and this replacement must be ASTA approved to BS1362.

### IMPORTANT:

If this appliance is fitted with a plug which is moulded onto the electric cable (i.e. non-rewirable) please note:

1. The plug must be thrown away if it is cut from the electric cable. There is a danger of electric shock if it is subsequently inserted into a socket outlet.
2. Never use the plug without the fuse cover fitted.
3. Should you wish to replace a detachable fuse carrier, ensure that the correct replacement is used (as indicated by marking or colour code).
4. Replacement fuse covers can be obtained from your local dealer or most electrical stockists.

***We strongly recommend that this machine is connected to the mains supply through a Residual Current Device (RCD).***

### EXTENSION CABLES

Ensure that extension cable insulation is rubber or neoprene, and that the cross section of each conductor is at least 2.5mm<sup>2</sup>. The maximum length of the cable should not exceed 25 Metres.

If the electrical connections are outdoors, then the plug AND socket MUST be of a BS approved waterproof design.

### WARNING

**DO NOT ATTEMPT ELECTRICAL INSTALLATION WORK IF YOU ARE IN ANY DOUBT AS TO HOW IT SHOULD BE DONE PROPERLY. CONSULT A QUALIFIED ELECTRICIAN.**

## WATER CONNECTIONS

**IMPORTANT: The pump must not be connected to the power supply until the hose/pipe installation is completed.**

If any part of the system is to be connected to the mains water supply, do ensure that you comply with your local water authority regulations.

Because of the variety of possible installations, no plumbing accessories are supplied as standard with your pump, (except for the Handy Pump 2, which is provided with a 4 metre inlet hose complete with a foot valve and filter). However, accessories designed specifically for this range of pumps are available from your CLARKE dealer and are listed on page 30.

The pump must always be installed and operated in a horizontal position i.e. with the outlet port facing vertically upwards. The fixing holes in the base should be used as necessary to secure the pump firmly in its operating position. (Not applicable to the Handy Pump 2, which is portable). Also, ensure that there is adequate air circulation around the motor.

Avoid situations where there is the risk of water coming into contact with the outside of the pump. Neither the motor or the terminal box are designed to be waterproof.

These notes are for guidance on how to achieve a proper working system.

The schematic diagram opposite illustrates a typical pipework installation.

The suction lift i.e. the vertical distance between the water level and the pump should not exceed the distance specified for your pump. (See Specifications, pages 9 to 11).

A foot valve and filter should be fitted to the lower end of the suction hose, as illustrated below, so as to help retain water in the suction system and to prevent the possibility of large foreign bodies entering the pump body.

A 1" BSP hose adapter will be required for connection to the inlet port. This is available from your CLARKE dealer.

The performance of your pump will be effected by the diameter of the inlet pipe - any restriction will greatly reduce the flow. We strongly recommend that you use a diameter pipe which is as large as practicable, with a suitable reducer for connection to the 1" BSP inlet adapter.

**NOTE: The Handy Pump 2 is provided with a 4 metre inlet hose complete with a foot valve and filter.**

The delivery hose should be attached to the outlet adapter which is supplied.

**IMPORTANT: In the case of the CBM250SS model, the hose MUST rise vertically for 70cm before elbows are connected.**

A gate valve may be installed in-line on the delivery side of the pump which can be set as required to regulate the flow of water. **DO NOT** place any such restriction on

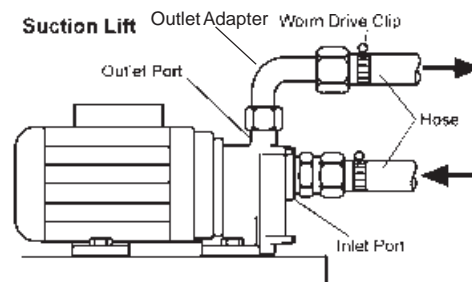

the suction side of the pump unless it is an isolator valve in a gravity fed system. It is IMPORTANT to note also, that these pumps should not be operated with the delivery valve completely closed.

To prevent unnecessary strain or possible distortion to the pump, ensure that adequate support is provided to the hoses and/or pipes. Remember they will be considerably heavier when filled with water.

Should sand, chemical or other contaminants come into contact with the pump, flush through with cold clean water as soon as possible.

Protect the pump and pipework from freezing. The formation of ice may cause serious damage.

Where the pump is to be a permanent fixture, the fittings to the pump **MUST** be flexible, i.e. a short piece of hose should be inserted between rigid metal pipework and the pump.

It is strongly recommended that in addition to the coarser foot filter, an inlet filter should be fitted to prevent the possibility of any foreign body from entering the pump. This is particularly important in the case of multi stage pumps CBM240, CBM240E & CBM250SS. A filter specifically designed for all pumps in the range is available from your CLARKE dealer - see Accessories on page 30.

The filter bowl is transparent allowing a visual check as to the condition of the filter cartridge. The filter cartridge is a washable net type, with a rated filtration of 60 microns, suitable for the efficient removal of suspended particles such as sand. The filter is NOT designed to filter mud, sludge etc.

### **CPE100TF, CBM100SS, CBM130SS, CBM250SS and CBM240E.**

These pumps are set up as BOOSTER PUMPS, described in greater detail below, and are provided with non-return valves. Additionally, 100TF & 240E models are provided with filters, (optional accessories for SS models - see your Clarke dealer for details). Non-return valves and filters are connected to the inlet port as follows:

Screw the non return valve into the inlet port, ensuring the arrow, stamped on the valve points inwards towards the inlet port. Tighten the valve, BUT DO NOT OVERTIGHTEN, then screw the filter on to the valve - again DO NOT OVERTIGHTEN. The filter should hang vertically when completed.

### **CBM240E**

This pump is set up as a BOOSTER Pump by incorporating the CLARKE EPC 1000 HYDROTRONIC UNIT - a computerised electronic device which automatically switches the pump ON and OFF whenever a tap, or other restriction in the outlet side of the pump, such as a spray lance etc., is turned ON or OFF.

Please ensure you are thoroughly familiar with the operation of this device by reading the enclosed leaflet describing its' operation and maintenance, before you operate the pump. It is important to note that in order for the hydrotronic unit to operate correctly, the maximum head ABOVE THE OUTLET OF THE HYDROTRONIC UNIT, is 14 metres.

i.e. Although the pump is capable of delivering water to a maximum head of 48 metres, the hydrotronic unit will not switch the pump ON if the vertical height above outlet of the unit is greater than 14 metres.

## CPE100TF, CBM100SS, CBM130SS and CBM250SS

These units are set up as a BOOSTER pumps by utilising an air chamber with a pressure regulator to provide a constant pressure at the outlet. All models are provided with non-return valves and Model CPE100TF is also provided with an inlet filter.

The pumps will automatically cut in when the water pressure reduces to 2.0 Bar, and cut out when the pressure reaches 3.5 Bar. (These pressures are 3.5 and 5.2 bar respectively for Model CBM250SS). These pressures are factory set and must not be altered. The pump may continue to operate for a short while, after the tap is turned off, until the cut-out pressure is reached.

In order for the system to operate correctly, it is necessary to pressurise the air chamber to 1.5 Bar (22psi), which is carried out as follows:

Unscrew the large protection cap on the end of the air chamber to reveal the air valve, and use an air line or foot pump to charge the chamber to the specified pressure, checking with a standard air pressure gauge until satisfied. Remember to replace the protection cap when completed.

**IMPORTANT: This procedure MUST be carried out BEFORE connecting to the water supply.**

## PRIMING

When suction lift is used to draw water into the pump it is essential that all connections and hoses are completely air tight, otherwise the system will not work.

Although the pump is a 'self priming' type, it is nevertheless necessary to completely fill the inlet side of the pump with water before being started for the first time, or if the system has been drained for maintenance or repair purposes. This is known as priming the pump and is carried out as follows :-

1. Locate and remove the small filler plug, situated on the top of the pump chamber, and **slowly** fill the pump with water until all air is expelled.

**NOTE: If a filter is fitted to your pump it is recommended that you remove the brass plug on top of the unit, and fill the bowl with water.**

In the case of the CPE100P, no filler plug is provided, and the pump body is therefore filled through the outlet port before its' connection

2. Adjust any device which may be fitted to the outlet side of the pump, so as to ensure as great a flow as possible.
3. Switch on the pump and check for leaks. Water should start to flow through the system after a short while. If, after 2-3 minutes, depending upon the suction depth, water does not flow, check to ensure:
  - a) The inlet pipe is completely secure and completely free from defects. Even a pin hole could prevent the pump from drawing water. This is the most common problem encountered when operating water pumps.
  - b) The pump body has been primed correctly, and is completely filled with water.

**NOTE: If the pump is gravity or pressure fed, priming will not be necessary, as the pressure of water will purge the system of air.**

## TROUBLE SHOOTING

REMEMBER that rate of flow is dependant upon the head - i.e. the greater the head the lower the flow. Check the specifications for your pump on pages 9 to 11.

The pump does not run	<ol style="list-style-type: none"> <li>1. No mains supply</li> <li>2. Impeller seized / blocked</li> </ol>	<ol style="list-style-type: none"> <li>1. Check fuse - replace if necessary (13 Amp).</li> <li>2. Disconnect pump from mains, disassemble, and clear blockage.</li> </ol>
Thermal overload has operated switching OFF	<ol style="list-style-type: none"> <li>1. Incorrect mains voltage</li> <li>2. Impeller seized / blocked</li> <li>3. Pump ran with hot water</li> <li>4. Pump ran dry</li> </ol>	<ol style="list-style-type: none"> <li>1. Check and rectify.</li> <li>2. Disconnect pump from mains. disassemble, &amp; clear blockage.</li> <li>3. Do not pump water at a temp. greater than 35°C.</li> <li>4. NEVER run your pump dry. Investigate the cause &amp; rectify.</li> </ol>
Pump runs but no output	<ol style="list-style-type: none"> <li>1. Air in pump housing</li> <li>2. Suction fault</li> <li>3. Suction height too great</li> </ol>	<ol style="list-style-type: none"> <li>1. Disconnect from the mains and prime pump correctly.</li> <li>2. Verify that suction pipe is completely sound and all connections are air tight.</li> <li>3. Check height is within spec. for your pump.</li> </ol>
Low or no Flow	<ol style="list-style-type: none"> <li>1. Blocked inlet pipe</li> <li>2. Blocked impeller</li> <li>3. Head too high</li> </ol>	<ol style="list-style-type: none"> <li>1. Investigate and rectify.</li> <li>2. Disassemble pump and clear blockage.</li> <li>3. Check that head is within spec.</li> </ol>

### PUMPS WITH HYDROTRONIC UNIT

Pump runs non-stop	<ol style="list-style-type: none"> <li>1. Leaks on output side or cuts in and out rapidly</li> <li>2. Non-Return valve faulty.</li> </ol>	<ol style="list-style-type: none"> <li>1. Ensure connections are water tight. Check to ensure no taps are leaking. Smallest leak will cause Hydrotronic unit to operate.</li> <li>2. Check and rectify.</li> </ol>
--------------------	---	--

### CPE100TF, CBM100SS, CBM130SS and CBM250SS

Pump switches on and off rapidly	<ol style="list-style-type: none"> <li>1. Low air pressure</li> <li>2. Membrane damaged</li> </ol>	<ol style="list-style-type: none"> <li>1. Check pressure and re-charge.</li> <li>2. Consult your CLARKE dealer.</li> </ol>
Pump switches on & off when no water is being drawn.	<ol style="list-style-type: none"> <li>1. Leak in output side.</li> <li>2. Non-Return valve faulty.</li> </ol>	<ol style="list-style-type: none"> <li>1. Investigate and rectify.</li> <li>2. Check and rectify.</li> </ol>
Pump does not switch OFF	<ol style="list-style-type: none"> <li>1. Pressure switch faulty</li> <li>2. No water at pump inlet</li> <li>3. Faulty Impeller</li> </ol>	<ol style="list-style-type: none"> <li>1. Consult your CLARKE dealer.</li> <li>2. Check for blockage.</li> <li>3. Disassemble and investigate.</li> </ol>

Should you still experience problems, then contact your Clarke dealer, or CLARKE International Service Department for advice.



## SPECIFICATIONS

### CPE100P

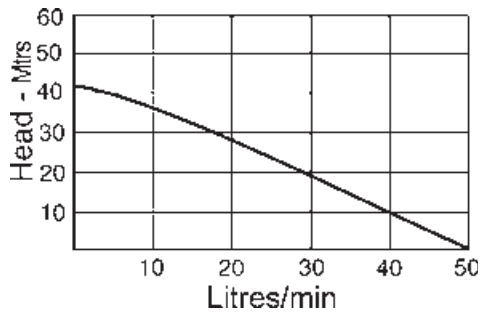

Motor .....	230V 50Hz
Power .....	700 Watts
Max. Flow .....	50 Litres/min
Max. Head .....	42 Metres
Max. Suction Height .....	9 Metres
Max Output Pressure .....	6 Bar
Part No. ....	7230630
Weight .....	6.8 Kg

### CPE100TF

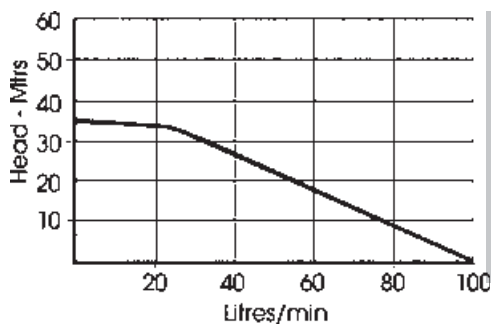

Motor .....	230V 50Hz
Power .....	700 Watts
Max. Flow .....	50 Litres/min
Max. Head .....	35 Metres
Max. Suction Height .....	9 Metres
ON/OFF Pressure .....	2/3.5 Bar
Part No. ....	7230640
Weight .....	14.4 Kg

### CPE120

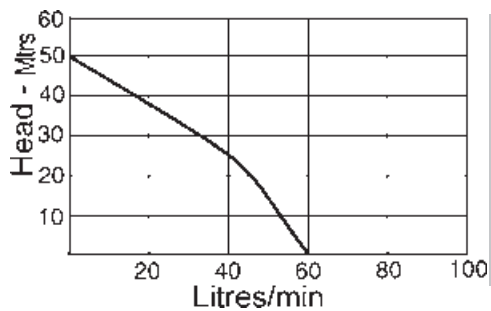

Motor .....	230V 50Hz
Power .....	1000 Watts
Max. Flow .....	61 Litres/min
Max. Head .....	50 Metres
Max. Suction Height .....	9 Metres
Max Output Pressure .....	8 Bar
Part No. ....	7230650
Weight .....	10.6 Kg

### CPE130SS

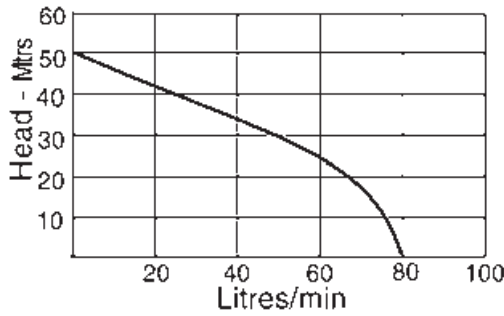

Motor .....	230V 50Hz
Power .....	1250 Watts
Max. Flow .....	81 L/min
Max. Head .....	50 Metres
Max. Suction Height .....	9 Metres
Part No. ....	7230680
Weight .....	19.6 Kg

### CBM 240 & 240E

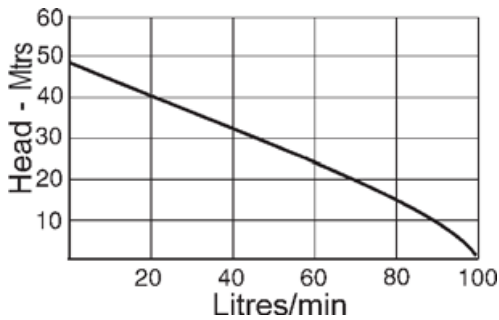

Motor .....	230V 50Hz
Power .....	1000 Watts
Max. Flow .....	101 L/min
Max. Head (240) .....	48 Metres
Max Head (240E) .....	14 Metres*
Max. Suction Height .....	7.5 Metres
Max Pressure (240) .....	8 Bar
ON/OFF Pressure (240E) .....	1.6/4.8 Bar
Part No.CBM240 .....	7230660
Part No.CBM240E .....	7230670
Weight (240/240E) .....	10.9/11.8 Kg

\* Max. head above Hydrotronic unit

### HANDY PUMP 2

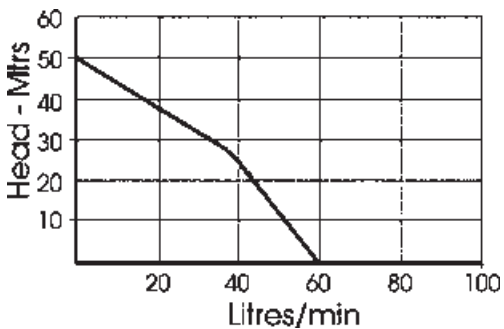

Motor .....	230V 50Hz
Power .....	1000 Watts
Max. Flow .....	61 L/min
Max. Head .....	50 Metres
Max. Suction Height .....	9 Metres
Part No. ....	7230690
Weight .....	12.2 Kg

### CBM100SS

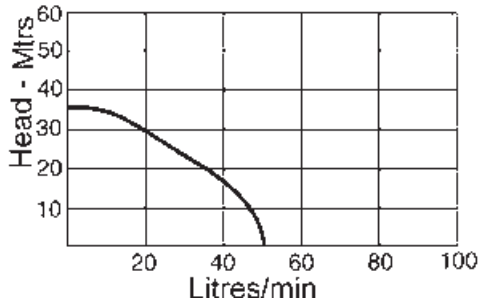

Motor ..... 230V 50Hz  
Power ..... 700 Watts  
Max. Flow ..... 51 L/min  
Max. Head ..... 35 Metres  
Max. Suction Height .... 9 Metres  
Air Reservoir ..... 24 Litres  
ON/OFF Pressure ..... 2.0/3.5 Bar  
Part No. .... 7238000  
Weight ..... 15.2 Kg

### CBM130SS

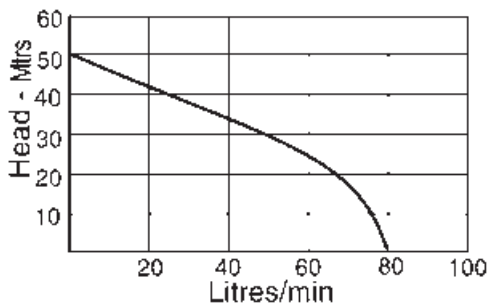

Motor ..... 230V 50Hz  
Power ..... 1250 Watts  
Max. Flow ..... 80 L/min  
Max. Head ..... 50 Metres  
Max. Suction Height ... 9 Metres  
Air Reservoir ..... 24 Litres  
ON/OFF Pressure ..... 2.0/3.5 Bar  
Part No. .... 7238010  
Weight ..... 18.2 Kg

### CBM250SS

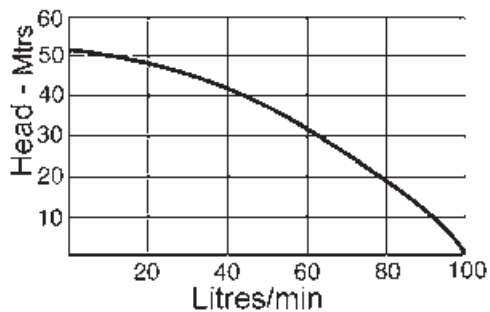

Motor ..... 230V 50Hz  
Power ..... 1250 Watts  
Max. Flow ..... 100 L/min  
Max. Head ..... 60 Metres  
Max. Suction Height .... 9 Metres  
Air Reservoir ..... 24 Litres  
ON/OFF Pressure ..... 3.5/5.2 Bar  
Part No. .... 7238020  
Weight ..... 19.2 Kg

CPE100P

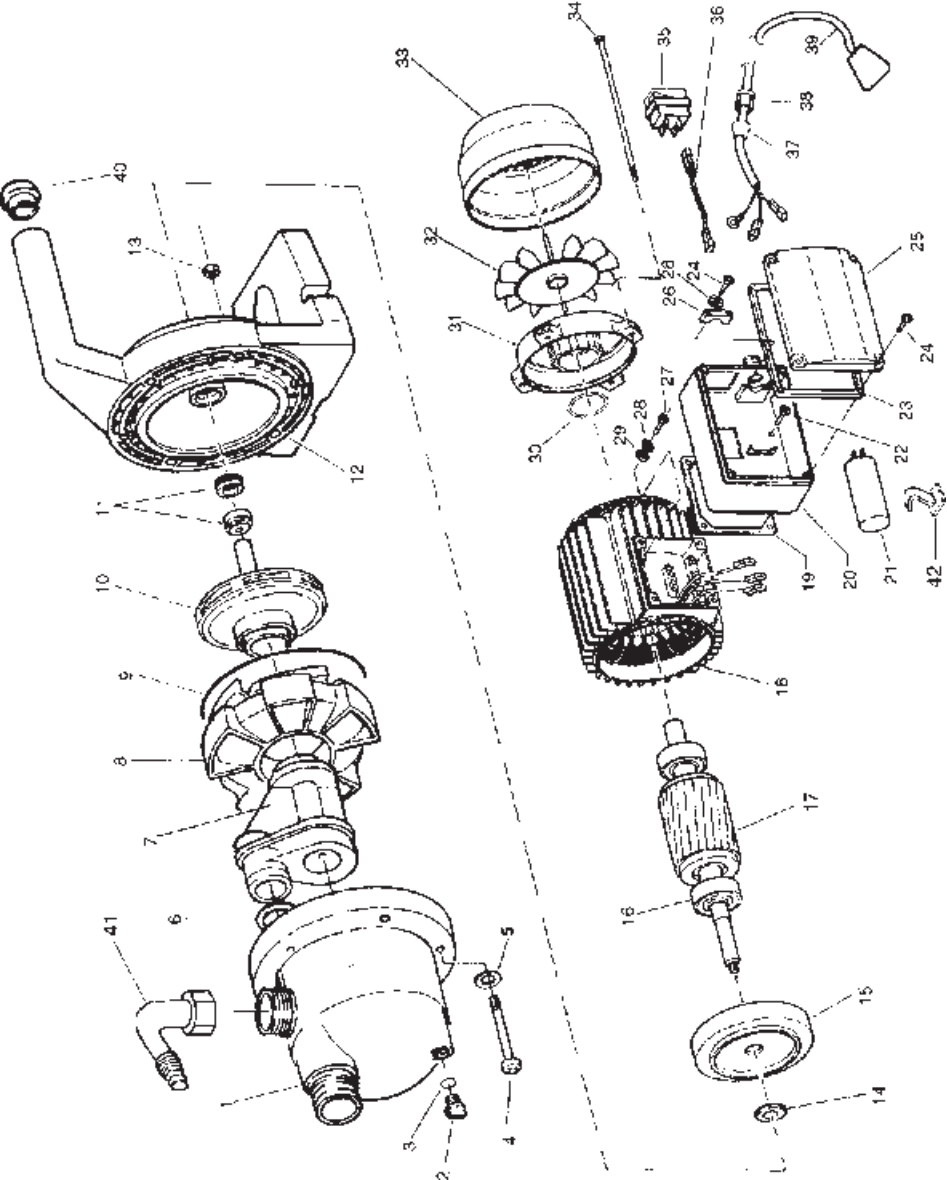

## CPE100P

Item	Description	Qty	Part No.
1	Pump Housing	1	LDS3600249
2	Cap 3/8" Gas	1	LDS3500009
3	Joint O-ring	1	LDP1200004
4	Screw	6	LDP1100002
5	Washer	6	LDP1120009
6	Joint O-ring	1	LDP1200024
7	Injector	1	LDS3250011
8	Diffuser	1	LDS3500247
9	Joint O-ring	1	LDP1200025
10	Impeller	1	LDS3250009
11	Mechanical Seal	1	LDP1220003
12	Flange With Handle	1	LDS3600151
13	Nut	6	LDP1110001
14	Joint	1	LDP1240001
15	Flange	1	LDS3120007
16	Bearings	2	LDP1180001
17	Shaft w/Bearings	1	LDS3101009
18	Stator	1	LDS3410099
19	Gasket	1	LDS3500199
20	Base Capacitor Holder	1	LDS3500214
21	Capacitor	1	LDP1360018
22	Screw	4	LDP1100004
23	Joint O-ring	1	LDP1200021
24	Screw	6	LDP1100006
25	Cap Capacitor	1	LDS3500218
26	Cable Fastener	1	LDP1510004
27	Screw	1	LDP1100055
28	Spring Washer	3	LDP1120003
29	Washer	1	LDP1120051
30	Spring Ring	1	LDP1120002
31	Cap MEC63	1	LDS3120004
32	Fan MEC 63	1	LDP1510014
33	Fan Cover MEC63	1	LDS3200011
34	Cross Screw	4	LDP1100043
35	Switch	1	LDP1380001
36	Cable	1	LDP1330001
37	Joint D.9	1	LDP1230001
38	Nut	1	LDP1510009
39	Cable	1	LDP1330013
40	Handle Cap	1	LDS3500288
41	Elbow	1	LDP1590063
42	Clip	1	LDS3500205

# CPE100TF

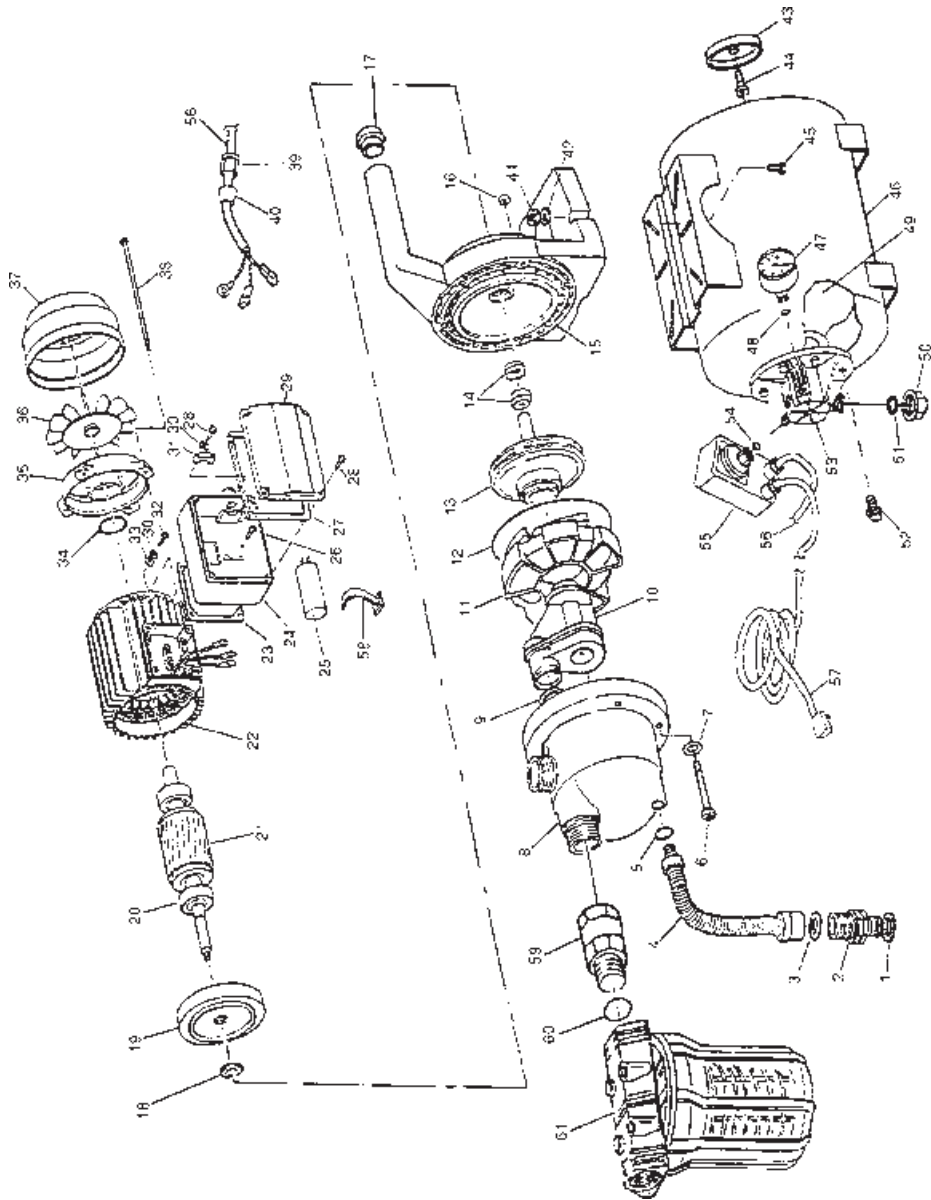

## CPE100TF

No.	Description	Qty	Part No.	No.	Description	Qty	Part No.
1	Joint .....	1	LDP1240006	32	Screw .....	1	LDP1100055
2	Nipple .....	1	LDS3500202	33	Washer .....	1	LDP1120051
3	Joint .....	1	LDP1240010	34	Spring ring .....	1	LDP1120002
4	Flexible Pipe .....	1	LDP1590005	35	Rear Shield Mech 63 ...	1	LDS3120004
5	Joint O-Ring .....	1	LDP1200010	36	Fan Mech 63 .....	1	LDP1510014
6	Screw .....	6	LDP1100002	37	Fan Cover Mech 63 ....	1	LDS3200011
7	Washer .....	6	LDP1120009	38	Cross Screw .....	4	LDP1100043
8	Pump Housing .....	1	LDS3600249	39	Nut .....	1	LDP1510009
9	Joint O-Ring .....	1	LDP1200024	40	Joint D9 .....	1	LDP1230001
10	Injector .....	1	LDS3250011	41	Nut .....	2	LDP1110003
11	Diffuser .....	1	LDS3500247	42	Washer .....	2	LDP1120005
12	Joint O-Ring .....	1	LDP1200025	43	Valve Cap .....	1	LDS3500166
13	Impeller .....	1	LDS3250009	44	Valve .....	1	LDP1230008
14	Mechanical Seal .....	1	LDP1220003	45	Screw .....	2	LDP1100005
15	Flange .....	1	LDS3600089	46	Tank .....	1	LDS3206005
16	Nut .....	6	LDP1110001	47	Manometer .....	1	LDP1170001
17	Cap Handle .....	1	LDS3500288	48	Joint O-Ring .....	1	LDP1200003
18	Joint .....	1	LDP1240001	49	Membrane .....	1	LDP1230009
19	Flange .....	1	LDS3120007	50	Cap 1" .....	1	LDP1590013
20	Bearing .....	2	LDP1180001	51	Joint .....	1	LDP1230010
21	Shaft with Bearings .....	1	LDS3101009	52	Screw .....	6	LDP1100026
22	Stator .....	1	LDS3410099	53	4 Way Flange .....	1	LDS3600203
23	Gasket .....	1	LDS3500199	54	Joint O-Ring .....	1	LDP1200016
24	Base Capacitor Holder .	1	LDS3500212	55	Pressure Switch .....	1	LDP1380012
25	Capacitor .....	1	LDP1360018	56	Cable .....	1	LDP1330002
26	Screw .....	4	LDP1100004	57	Cable .....	1	LDP1330013
27	Joint O-Ring .....	1	LDP1200021	58	Clip .....	1	LDS3500205
28	Screw .....	6	LDP1100006	59	Non Ret Valve m/f 1" ..	1	LDS3600099
29	Cap Capacitor Holder..	1	LDS3500218	60	Joint O-Ring .....	1	LDP1200002
30	Spring Washer .....	1	LDP1120003	61	Filter .....	1	LDP1591076
31	Cable Fastener .....	1	LDP1510024				

# CPE130SS

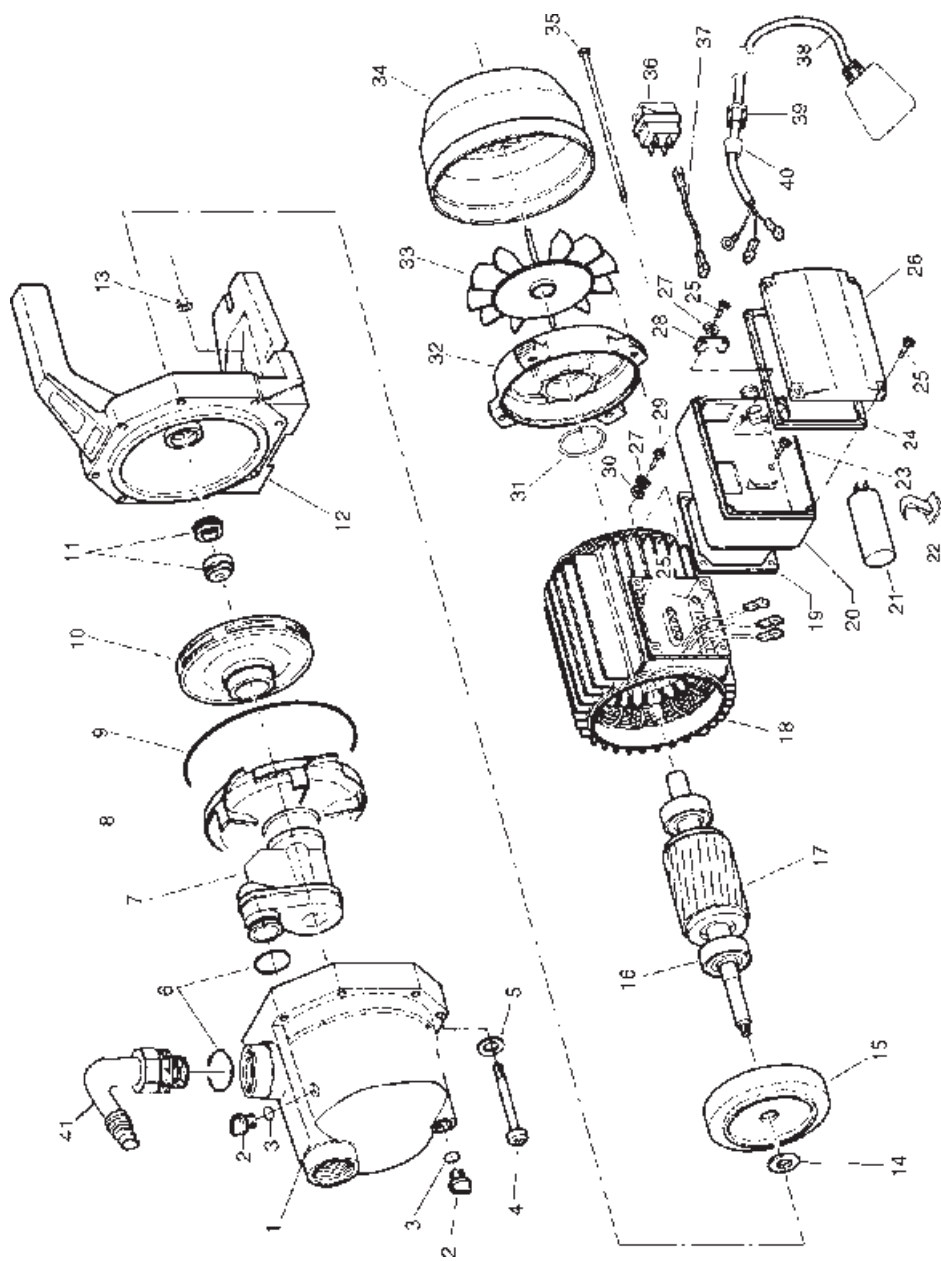



## CPE130SS

Item	Description	Qty	Part No.
1	Pump Housing	1	LDS3220002
2	Screw 3/8" Gas	2	LDS3500009
3	Joint O-Ring	2	LDP1200004
4	Screw	8	LDP1100025
5	Washer	8	LDP1120008
6	Joint O-Ring	2	LDP1200002
7	Injector 130	1	LDS3250005
8	Diffuser	1	LDS3500036
9	Joint O-Ring	1	LDP1200001
10	Impeller 130	1	LDS3150003
11	Mechanical Seal	1	LDP1220003
12	Flange	1	LDS3600105
13	Nut	8	LDP1110001
14	Joint	1	LDP1240001
15	Flange MEC 63/71	1	LDS3120001
16	Bearing	2	LDP1180001
17	Shaft w/Bearings	1	LDS3111003
18	Stator 130	1	LDS3410095
19	Gasket 63/71	1	LDS3500199
20	Base Capacitor Holder	1	LDS3500214
21	Capacitor	1	LDP1360001
22	Clip	1	LDS3500205
23	Screw	4	LDP1100004
24	Joint O-Ring	1	LDP1200021
25	Screw	6	LDP1100006
26	Cap Capacitor Holder	1	LDS3500218
27	Spring Washer	3	LDP1120003
28	Cable Fastener	1	LDP1510004
29	Screw	1	LDP1100055
30	Washer	1	LDP1120051
31	Spring Ring	1	LDP1120001
32	Rear Shield MEC 71	1	LDS3120002
33	Fan MEC 71	1	LDP1510001
34	Fan Cover MEC 71	1	LDS3200010
35	Cross Screw	4	LDP1100001
36	Switch	1	LDP1380001
37	Cable	1	LDP1310001
38	Cable	1	LDP1330013
39	Nut	1	LDP1510009
40	Joint D9	1	LDP1230001
41	Elbow	1	LDS3600056

# CPE120

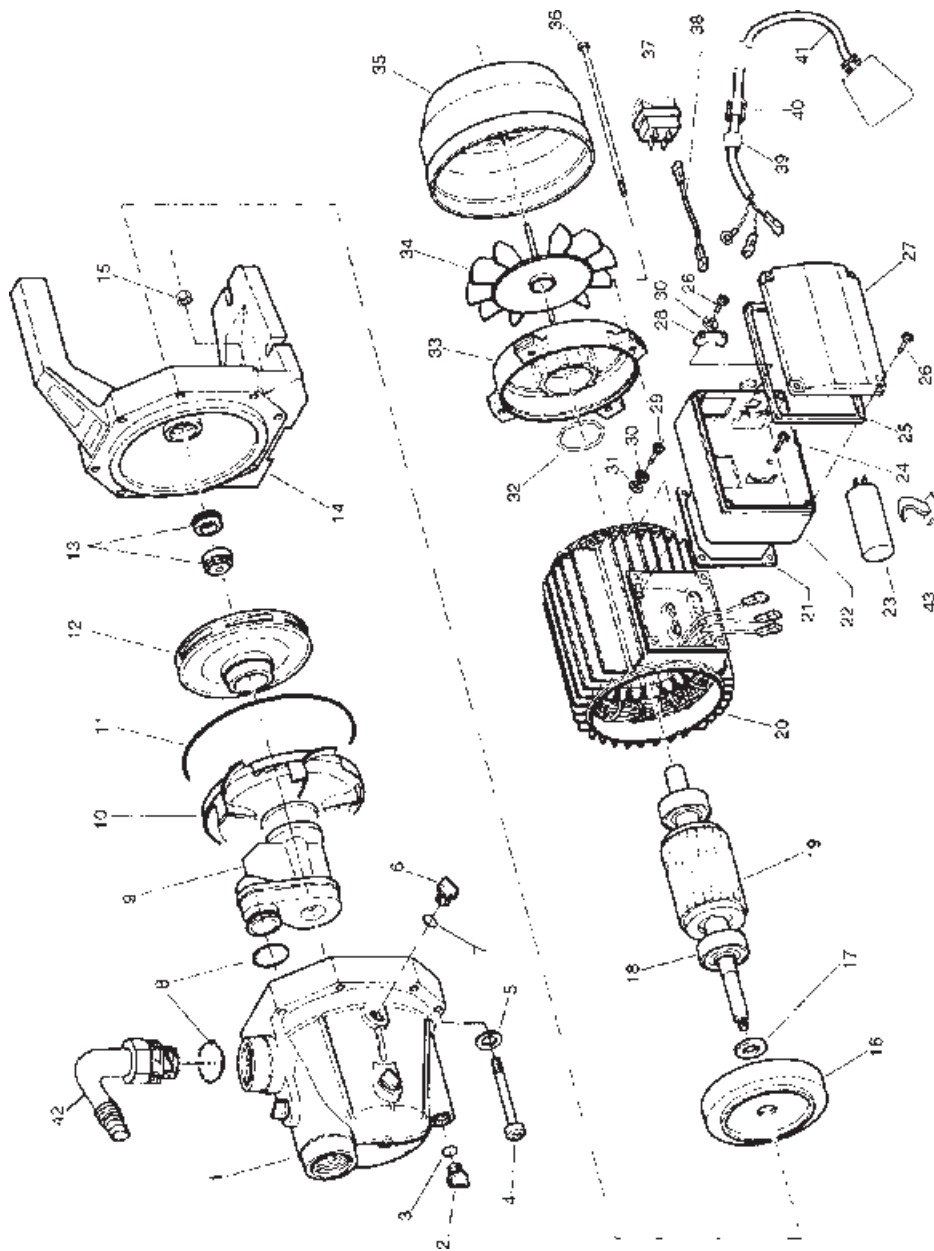

## CPE120

Item	Description	Qty	Part Number
1	Pump Housing .....	1	LDS3600030
2	Screw 3/8" Gas .....	2	LDS3500009
3	Joint O-Ring .....	2	LDP1200004
4	Screw .....	8	LDP1100002
5	Washer .....	8	LDP1120009
6	Screw 1/4" Gas .....	2	LDS3500008
7	Joint O-Ring .....	2	LDP1200003
8	Joint O-Ring .....	1	LDP1200002
9	Injector 120 .....	1	LDS3250004
10	Diffuser .....	1	LDS3500036
11	Joint O-Ring .....	1	LDP1200011
12	Impeller .....	1	LDS3150002
13	Mechanical Seal .....	1	LDP1220003
14	Flange Mec 63/71 .....	1	LDS3600105
15	Nut .....	8	LDP1110001
16	Joint .....	1	LDP1240001
17	Exterior Flange MEC 7 .....	1	LDS3120001
18	Bearing .....	2	LDP1180002
19	Shaft w/Bearings 120 .....	1	LDS3111002
20	Stator 120 .....	1	LDS3410058
21	Gasket .....	1	LDS3500199
22	Base Capacitor Holder .....	1	LDS3500214
23	Capacitor 120 .....	1	LDP1360002
24	Screw .....	4	LDP1100004
25	Joint O-Ring .....	1	LDP1200021
26	Screw .....	6	LDP1100006
27	Cover .....	1	LDS8500218
28	Cable Fastener .....	1	LDP1510004
29	Screw .....	1	LDP1100055
30	Spring Washer .....	3	LDP1120003
31	Washer .....	1	LDP1120051
32	Waved Ring .....	1	LDP1120001
33	Rear Shield MEC71 .....	1	LDS3120002
34	Fan MEC71 .....	1	LDP1510001
35	Fan Cover MEC71 .....	1	LDS3200010
36	Cross Screw .....	4	LDP1100001
37	Switch .....	1	LDP1380001
38	Cable .....	1	LDP1310001
39	Joint D9 .....	1	LDP1510009
40	Nut .....	1	LDP1510008
41	Cable .....	1	LDP1330013
42	Elbow .....	1	LDS3600056
43	Clip .....	1	LDS3500205

# CBM240

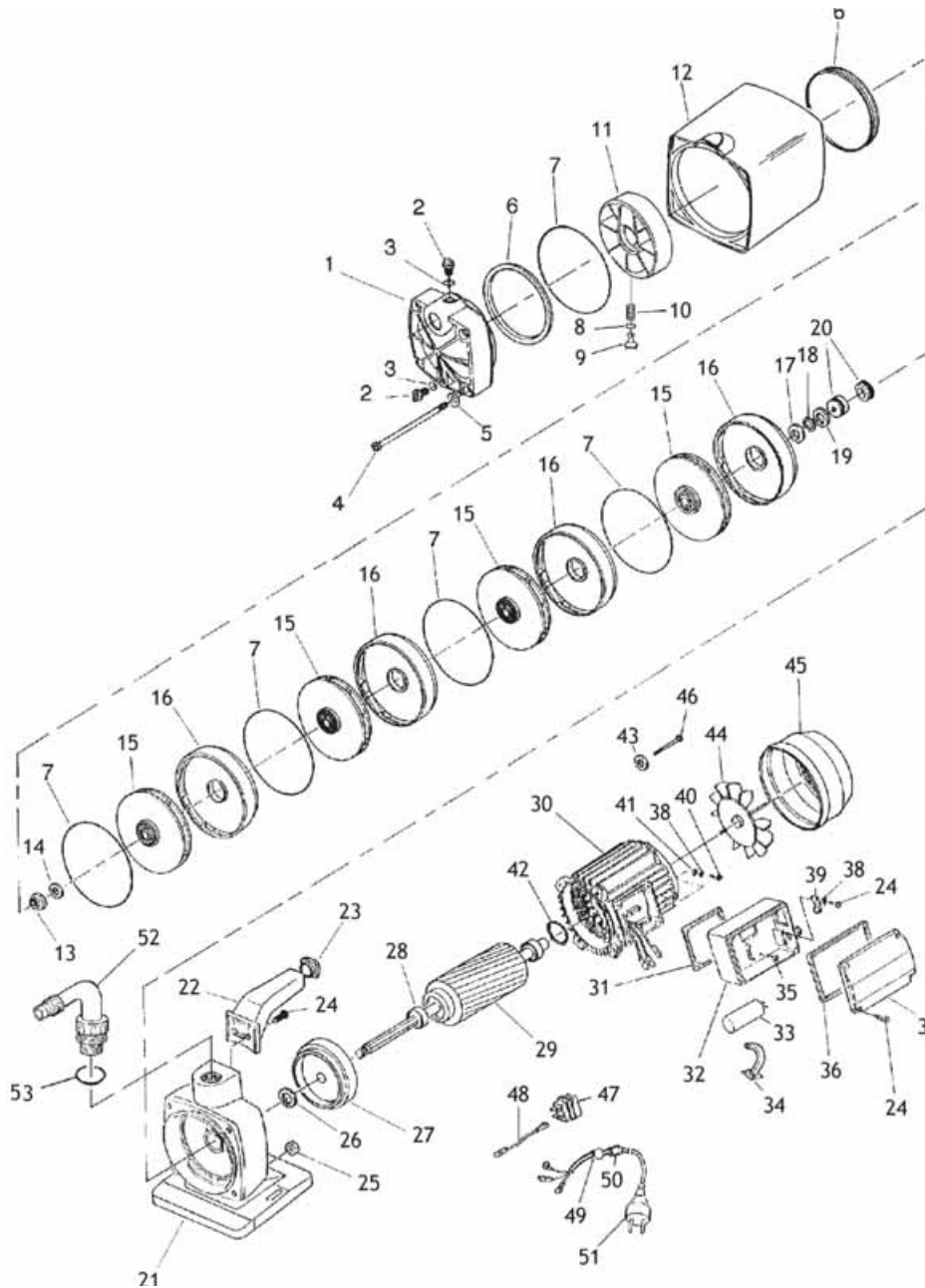

## CBM240

No.	Description	Qty	Part No.	No.	Description	Qty	Part No.
1	Flange Mc 1" Gas .....		LDS3500280	28	Bearing .....		LDP1180006
2	Screw 3/8" Gas .....		LDS3500009	29	Shaft With Bearings .....		LDS3111009
3	Joint O-ring .....		LDP1200004	30	Stator .....		LDS3410207
4	Cross Screw .....		LDP1100040	31	Gasket 63/71 .....		LDS3500199
5	Spring-washer .....		LDP1120021	32	Base Capacitor Holder ....		LDS3500214
6	Joint O-ring .....		LDP1240016	33	Capacitor .....		LDP1360002
7	Joint O-ring .....		LDP1200014	34	Clip .....		LDS3500205
8	Joint O-ring .....		LDP1200039	35	Screw .....		LDP1100004
9	Adjuster .....		LDS3500402	36	Joint O-ring .....		LDP1200021
10	Spring .....		LDP1130006	37	Cap Capacitor Holder ....		LDS3500218
11	Counterflange .....		LDS3500403	38	Spring-washer .....		LDP1120003
12	Pipe Mc .....		LDS3500284	39	Cable Fastener .....		LDP1510004
13	Nut .....		LDP1110009	40	Earth Screw .....		LDP1100055
14	Washer .....		LDP1120014	41	Washer .....		LDP1120051
15	Impeller .....		LDS3250027	42	Waved Ring .....		LDP1120001
16	Diffuser .....		LDS3250006	43	Spring-washer .....		LDP1120030
17	Washer .....		LDP1120028	44	Fan Mec 71 .....		LDP1510001
18	Ring .....		LDP1120022	45	Fan Cover Mec 71 .....		LDS3200010
19	Washer .....		LDP1120027	46	Screw .....		LDP1100046
20	Mechanical Seal .....		LDP1220003	47	Switch .....		LDP1380044
21	Pump Housing .....		LDS3600121	48	Cable Blue .....		LDP1310001
22	Handle Mc .....		LDS3500286	49	Joint D9 .....		LDP1230001
23	Handle Cap Mc .....		LDS3500287	50	Nut .....		LDP1510009
24	Screw .....		LDP1100006	51	Cable Uk Plug .....		LDP1330013
25	Nut .....		LDP1110013	52	Elbow .....		LDS3600056
26	Joint .....		LDP1240014	53	Joint O-ring .....		LDP1200002
27	Anterior Flange Mec 71 ...		LDS3120001				

# CBM240E

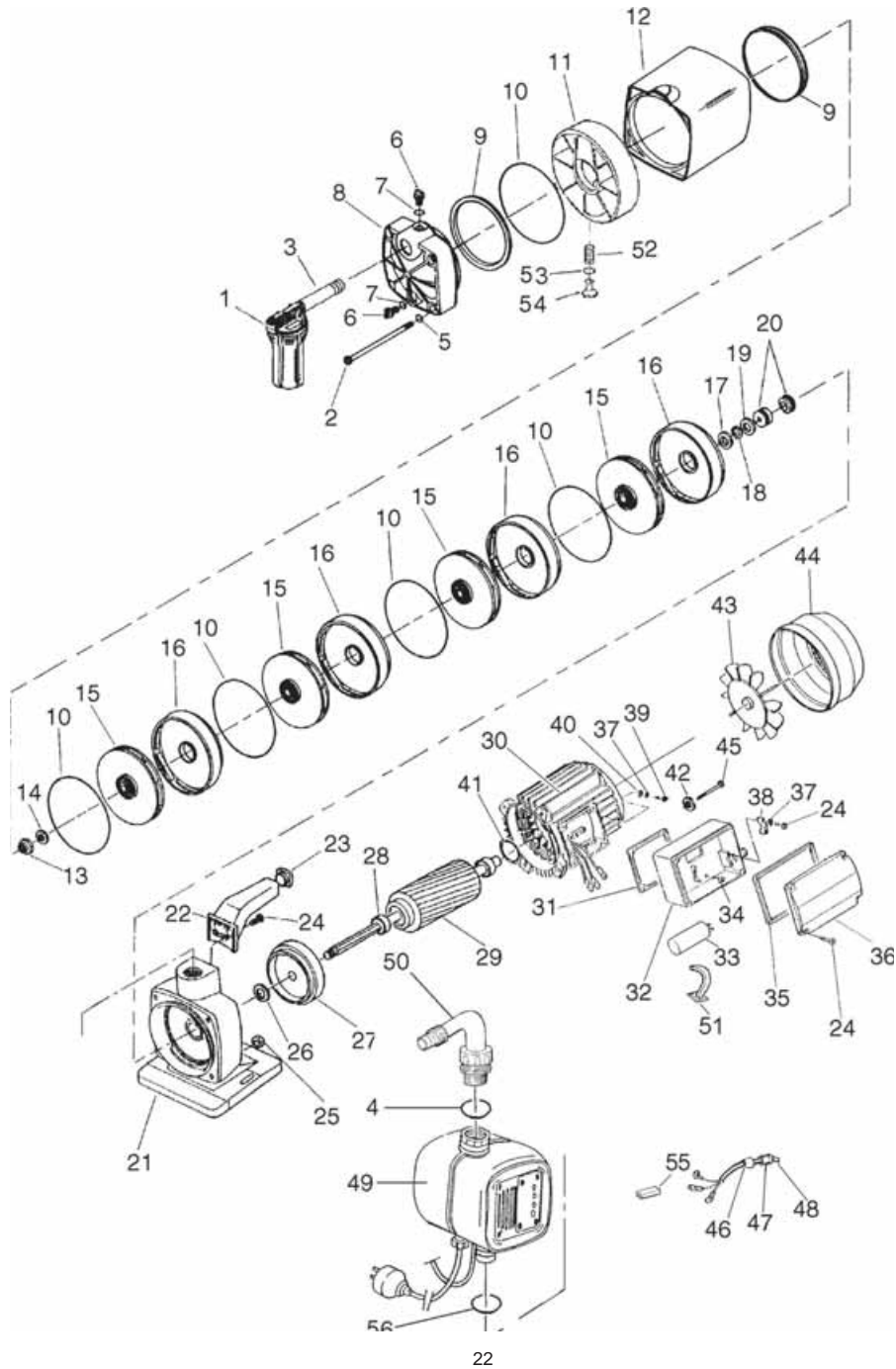

## CBM240E

No.	Description	Qty	Part No.	No.	Description	Qty	Part No.
1	Filter		LDP1591076	29	Shaft With Bearings		LDS3111009
2	Cross Screw		LDP1100040	30	Stator		LDS3410207
3	Nipple		LDP1590023	31	Gasket 63/71		LDS3500199
4	Joint O-ring		LDP1200002	32	Base Capacitor Holder		LDS3500212
5	Spring-washer		LDP1120021	33	Capacitor		LDP1360002
6	Screw 3/8" Gas		LDS3500009	34	Screw		LDP1100004
7	Joint O-Ring		LDP1200004	35	Joint O-Ring		LDP1200021
8	Flange MC 1" Gas		LDS3500280	36	Cap Capacitor Holder		LDS3500218
9	Joint O-Ring		LDP1240016	37	Spring-washer		LDP1120003
10	Joint O-Ring		LDP1200014	38	Cable Fastener		LDP1510004
11	Counterflange		LDS3500403	39	Earth Screw		LDP1100055
12	Pipe Mc		LDS3500284	40	Washer		LDP1120051
13	Nut		LDP1110009	41	Waved-Ring		LDP1120001
14	Washer		LDP1120014	42	Spring-washer		LDP1120030
15	Impeller		LDS3250027	43	Fan Mec 71		LDP1510001
16	Diffuser		LDS3250006	44	Fan Cover Mec 71		LDS3200010
17	Washer		LDP1120028	45	Screw		LDP1100046
18	Ring		LDP1120022	46	Joint D9		LDP1230001
19	Washer		LDP1120027	47	Nut		LDP1510009
20	Mechanical Seal		LDP1220003	48	Cable		LDS1330040
21	Pump Housing		LDS3600121	49	Hydrotronic Blue		LDCK010004
22	Handle Mc		LDS3500286	50	Elbow		LDS3600056
23	Handle Cap Mc		LDS3500287	51	Clip		LDS3500205
24	Screw		LDP1100006	52	Spring		LDP1130006
25	Nut		LDP1110013	53	Joint O-Ring		LDP1200039
26	Joint		LDP1240014	54	Obturator		LDS3500402
27	Anterior Flange Mec 71		LDS3120001	55	Tab Terminal		LDP1390011
28	Bearing		LDP1180006	56	Joint O-Ring		LDP1200040

# HANDY PUMP 2

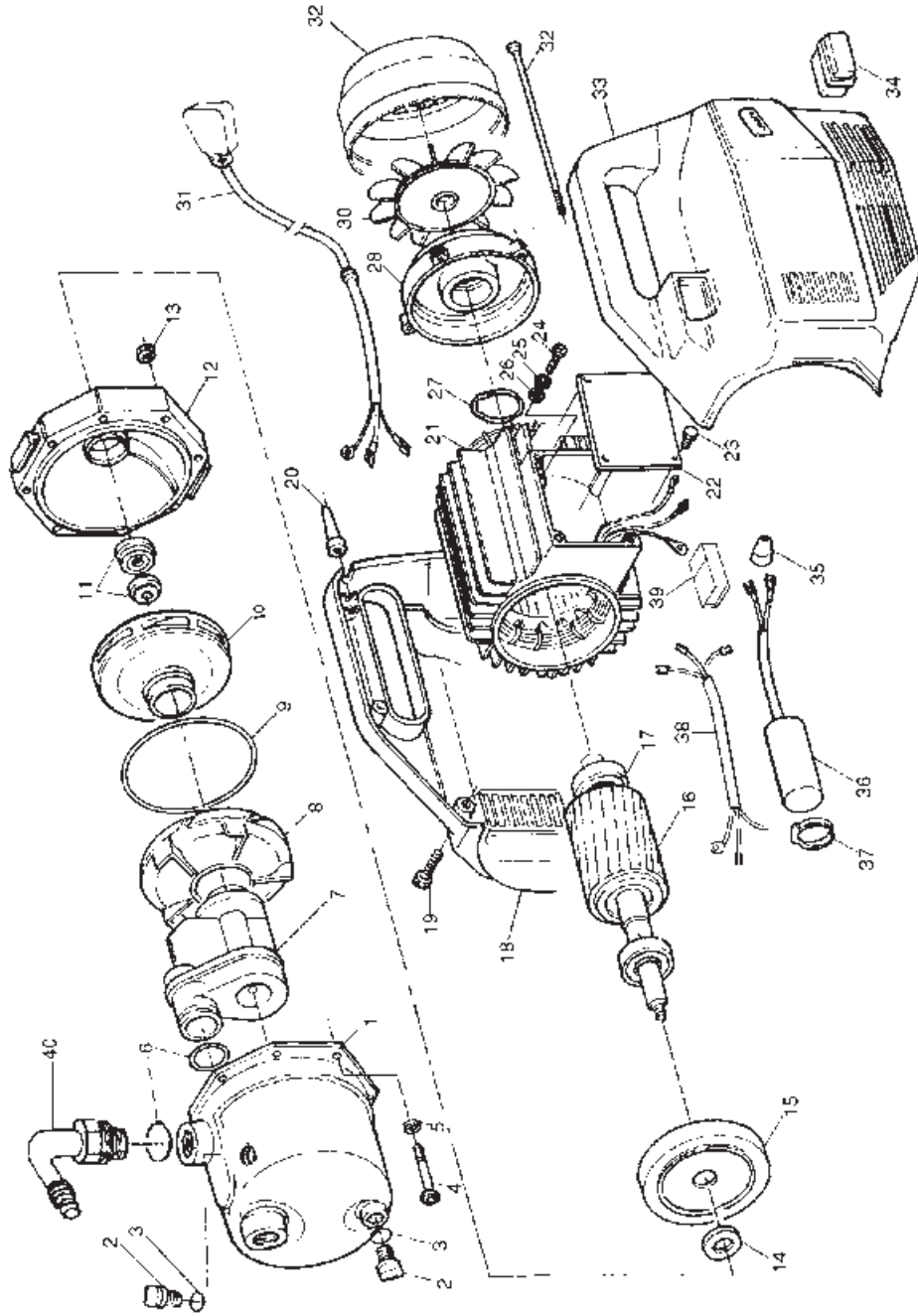



## HANDY PUMP 2

Item	Description	Qty	Part Number
1	Pump Housing	1	LDS3220002
2	Screw 3/8" Gas	2	LDS3500009
3	Joint O-Ring	2	PLD1200004
4	Screw	8	PLD1100025
5	Washer	8	PLD1120006
6	Joint O-Ring	2	PLD1200002
7	Injector	1	SLD3250004
8	Diffuser	1	SLD3500036
9	Joint O-Ring	1	LDP1200001
10	Impeller	1	LDS3150002
11	Mechanical Seal	1	LDP1220003
12	Flange	1	LDS3600149
13	Nut	8	LDP1110001
14	Joint	1	LDP1240001
15	Anterior Flange	1	LDS3120001
16	Shaft w/Bearings	1	LDS3111002
17	Bearing	2	LDP1180002
18	Left Body	1	LDS3500324
19	Screw	7	LDP1100006
20	Grommet D9	1	LDP1230003
21	Stator	1	LDS3410054
22	Cover	1	LDP1510026
23	Screw	2	LDP1100004
24	Screw	1	LDP1100055
25	Spring washer	1	LDP1120003
26	Washer	1	LDP1120051
27	Spring Ring	1	LDP1120001
28	Rear Shield	1	LDS2130002
29	Fancover	1	LDP1510001
30	Cable	1	LDP1330032
31	Fan Cover	1	LDS3200010
32	Cross Screw	1	LDP1100001
33	Right Body	1	LDS3500325
34	Switch	1	LDP1380001
35	Joint D20	1	LDP1230005
36	Capacitor	1	LDP1360016
37	Strap	1	LDP1390009
38	Cable	1	LDP1310021
39	Connector	1	LDP1390011
40	Elbow	1	LDS3600056

# CBM100SS & CBM 130SS

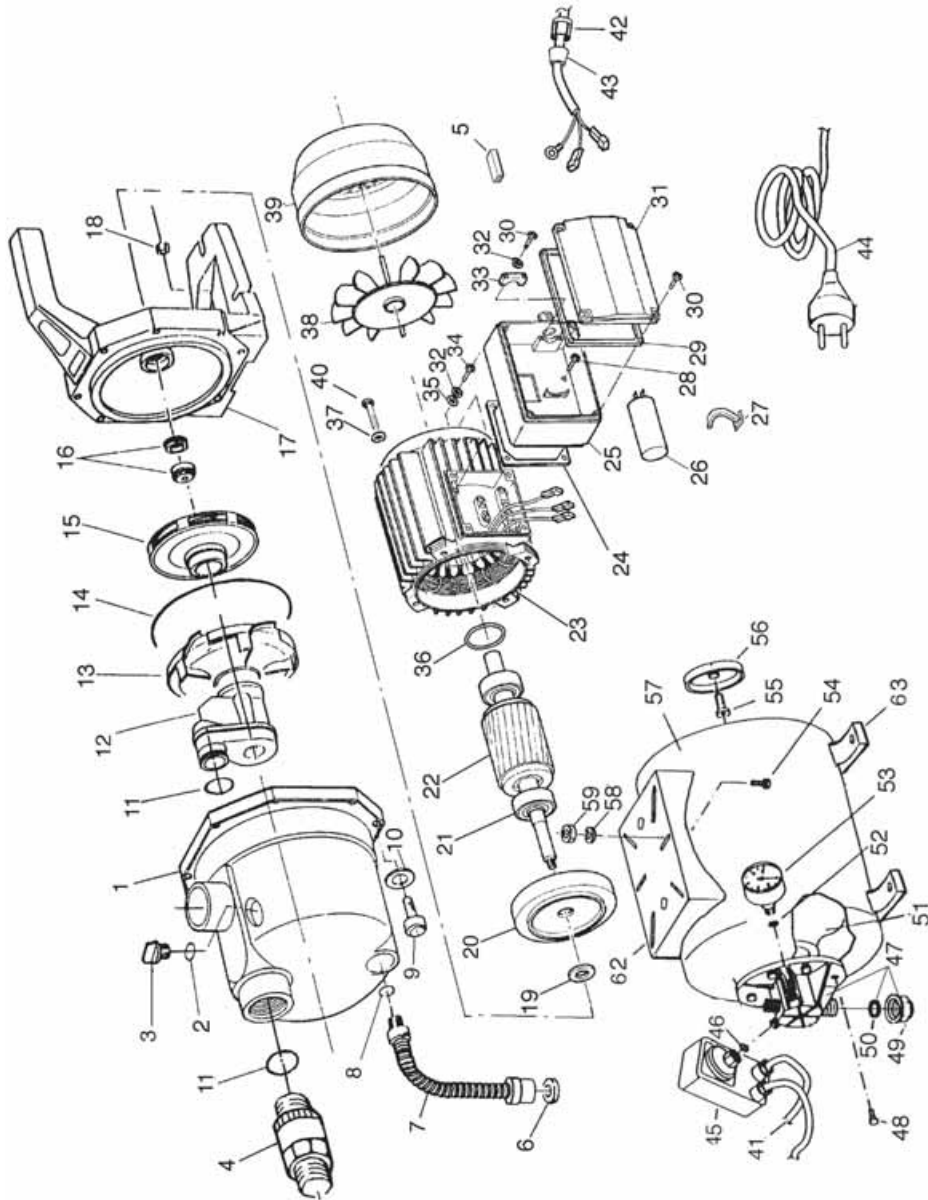

## CBM100SS & CBM 130SS

No.	Description	Qty	Part No.	No.	Description	Qty	Part No.
1	Pump housing		LPS3220002	30	Screw		LPP1100006
2	Joint O.Ring		LPP1200004	31	Cap capacitor holder		LPS3500218
3	Screw 3/8" GAS		LPS3500009	32	Spring-washer		LPP1120003
4	Non-return valve M/M 1"		LPS3600098	33	Cable Clamp CBM 130SS		LPP1510004
5	Tab terminal		LPP1390011	34	Earth screw		LPP1100055
6	Joint		LPP1240025	35	Washer		LPP1120051
7	Flexible pipe		LPP1690037	36	Waved ring CBM 130SS		LPP1120001
8	Joint O.Ring		LPP1200004	36	Waved-ring CBM 100SS		LPP1120002
9	Screw		LPP1100025	37	Spring-washer		LPP1120030
10	Washer		LPP1120008	38	Fan CBM 130SS		LPP1510001
11	Joint O.Ring		LPP1200002	38	Fan CBM 100SS		LPP1510014
12	Injector CBM 130SS		LPS3250005	39	Fan cover CBM 130SS		LPP1510043
12	Injector CBM 100SS		LPS3250014	39	Fan cover CBM 100SS		LPS3200011
13	Diffuser		LPS3500036	40	Screw CBM 130SS		LPP1100046
14	Joint O.Ring		LPP1200001	40	Screw CBM 100SS		LPP1100054
15	Impeller CBM 130SS		LPS3150003	41	Cable		LPP1330008
15	Impeller CBM 100SS		LPS3150036	42	Nut		LPP1510009
16	Mechanical seal		LPP1220003	43	Joint d9		LPP1230001
17	Flange Mec 63/71		LPS3600385	44	Cable		LPP1330069
18	Nut		LPP1110001	45	Pressure switch		LPP1380012
19	Joint		LPP1240001	46	Joint O.Ring		LPP1200016
20	flange CBM 130SS		LPS3120001	47	4-way flange		LPS3600380
20	Flange CBM 100SS		LPS3120007	48	Screw		LPP1100026
21	Bearing CBM 130SS		LPP1180011	49	Cap 1" GAS		LPS3500527
21	Bearing CBM 100SS		LPP1180007	50	Joint O.Ring		LPP1200049
22	Shaft w/ brgs CBM 100SS		LPS3101009	51	Membrane		LPP1230022
22	Shaft w/ brgs CBM 130SS		LPS3111008	52	Joint O.Ring		LPP1200003
23	Stator CBM 130SS		LPS3410208	53	Manometer		LPP1170001
23	Stator CBM 100SS		LPS3410187	54	Screw		LPP1100100
24	Gasket 63/71		LPS3500199	55	Valve		LPP1230008
25	Base capacitor holder		LPS3500212	56	Valve cap		LPS3500166
26	Capacitor CBM 130SS		LPP1360001	57	Shell stainless steel 24ft.		LPS3220018
26	Capacitor CBM 100SS		LPP1360018	58	Washer		LPP1120005
27	Clip		LPS3500205	59	Nut		LPP1110003
28	Screw		LPP1100004	62	Bracket		LPP1510049
29	Joint O.Ring		LPP1200021	63	Feet		LPP1510048

# CBM250SS

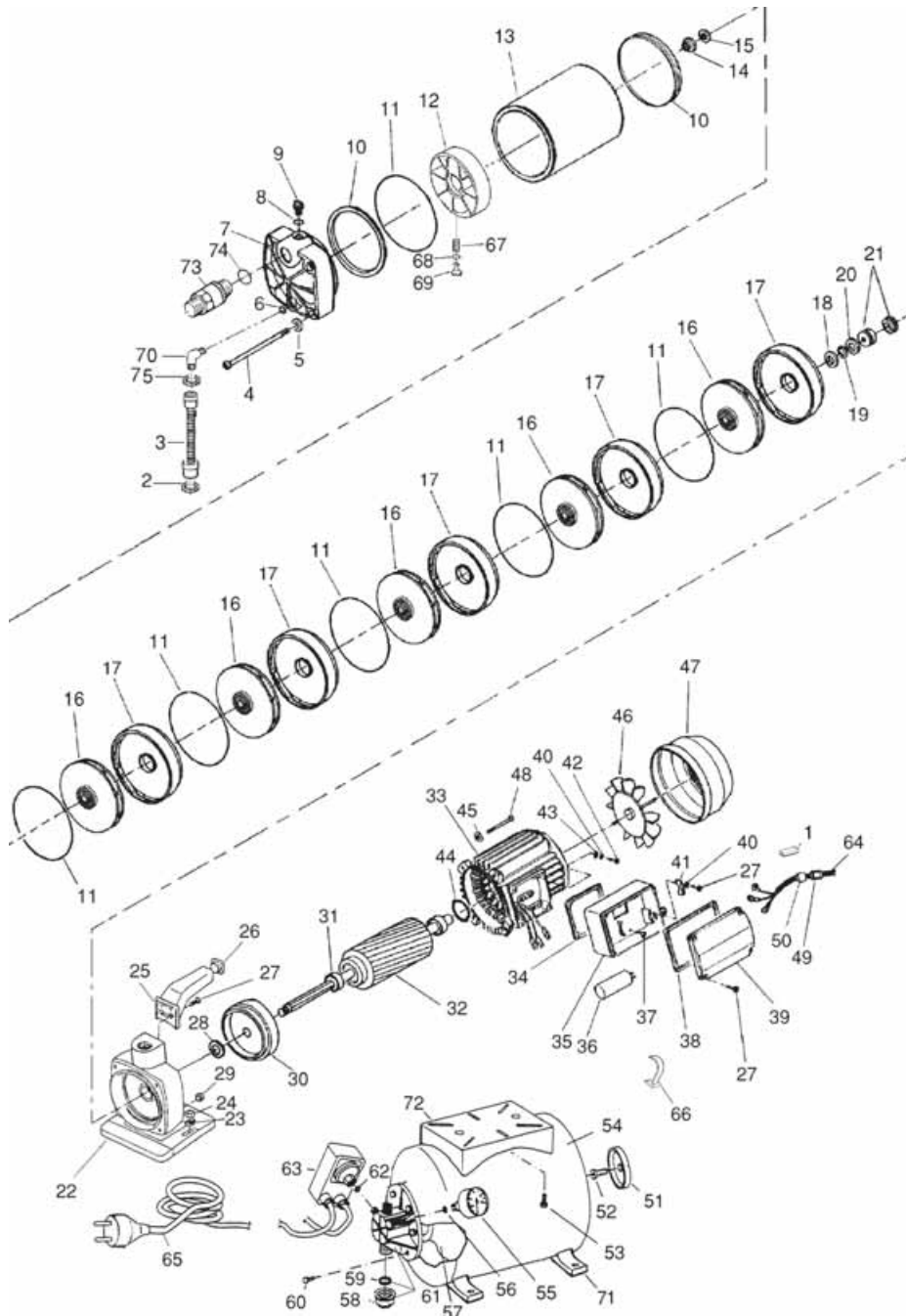

## CBM250SS

No.	Description	Qty	Part No.	No.	Description	Qty	Part No.
1	Tab Terminal		LDP1390011	39	Cap Capacitor Holder		LDS3500218
2	Joint		LDP1240025	40	Spring washer		LDP1120003
3	Flexible Pipe		LDP1690044	41	Cable fastener		LDP1510004
4	Cross Screw		LDP1100039	42	Earth screw		LDP1100055
5	Spring Washer		LDP1120021	43	Washer		LDP1120051
6	Joint O-Ring		LDP1200010	44	Waved ring		LDP1120001
7	Flange MC 1" GAS		LDS3500280	45	Spring-washer		LDP1120030
8	Joint O-Ring		LDP1200004	46	Fan Mec 71		LDP1510001
9	Screw 3/8" GAS		LDS3500009	47	Fan cover Mec 71		LDS3200010
10	Joint		LDP1240009	48	Screw		LDP1100046
11	Joint O-Ring		LDP1200014	49	Nut		LDP1510009
12	Counterflange		LDS3500403	50	Joint D9		LDP1230001
13	Jacket inox		LDP1600014	51	Valve cap		LDS3500166
14	Nut		LDP1110009	52	Valve		LDP1230008
15	Washer		LDP1120014	53	Screw		LDP1100023
16	Impeller		LDS3250027	54	Shell stainless steel 24ft.		LDS3220018
17	Diffuser		LDS3250006	55	Manometer		LDP1170001
18	Washer		LDP1120028	56	Joint O-Ring		LDP1200003
19	Ring		LDP1120022	57	Gauge		LDP1230022
20	Washer		LDP1120027	58	Cap 1" GAS		LDS3500527
21	Mechanical Seal		LDP1220003	59	Joint O-Ring		LDP1200049
22	Pump housing		LDS3600121	60	Screw		LDP1100026
23	Washer		LDP1120005	61	4-way flange		LDS3600380
24	Nut		LDP1110003	62	Joint O-Ring		LDP1200016
25	Handle MC		LDS3500286	63	Pressure switch		LDP1380012
26	Handle Cap MC		LDS3500287	64	Cable		LDP1330008
27	Screw		LDP1100006	65	Cable		LDP1330069
28	Joint		LDP1240014	66	Clip		LDS3500205
29	Nut		LDP1110013	67	Spring		LDP1130006
30	Anterior flange Mec 71		LDS3120001	68	Joint O-Ring		LDP1200039
31	Bearing		LDP1180006	69	Adjuster		LDS3500402
32	Shaft with bearings		LDS3111010	70	Elbow		LDP1690030
33	Stator		LDS3410208	71	Feet		LDP1510048
34	Gasket 63/71		LDS3500199	72	Bracket		LDP1510049
35	Base capacitor holder		LDS3500212	73	Non-return valve M/M 1"		LDS3600098
36	Capacitor		LDP1360001	74	Joint O-Ring		LDP1200002
37	Screw		LDP1100004	75	Joint		LDP1240005
38	Joint O-Ring		LDP1200021				

## ACCESSORIES

Please contact your CLARKE dealer who will be happy to advise you regarding the accessories listed below.

1" Foot Valve Filter .....	7950561
1" BSP Spigot Hose Connector .....	7950210
1" I.D. Reinforced Hose for suction and delivery. ....	7955010
1" I.D. Layflat Hose for delivery only. ....	7955110
Non-Return Valve (male/female for CPE100P) .....	LDS3600099
Non-Return Valve (male/male fitting) .....	LDS3600098
Filter Assembly c/w Cartridge .....	LDP1591072
Filter Cartridge .....	LDP1591076

## SPARE PARTS & SERVICING

For Spare Parts and Service, please contact your nearest dealer,  
or CLARKE International, on one of the following numbers.

**PARTS & SERVICE TEL: 020 8988 7400**

**PARTS & SERVICE FAX: 020 8558 3622**

**or e-mail as follows:**

**PARTS: [Parts@clarkeinternational.com](mailto:Parts@clarkeinternational.com)**

**SERVICE: [Service@clarkeinternational.com](mailto:Service@clarkeinternational.com)**



**This is an important document and should be retained**

## **DECLARATION OF CONFORMITY**



We declare that this product complies with the following standards/directives:

- **98/37/EC**
- **2000/14/EC**

For Guaranteed Sound Power Levels, please refer to 'Specifications'

Description: **NON-SUBMERSIBLE WATER PUMP**

Model No: **ALL CBM and CPE RANGE  
and HANDY PUMP 2**

Serial (Batch) No: **See Product Date Plate**

Signed:   
Service Manager

**Clarke** INTERNATIONAL  
Hemnal Street, Epping, Essex CM16 4LG