

# Clarke® *PUMP*



## **SUBMERSIBLE WATER PUMP** **Model: ISP11A**

### **OPERATING & MAINTENANCE INSTRUCTIONS**



LS0809

Thank you for purchasing this Clarke Submersible Pump.

This highly efficient centrifugal pump is ideally suited for draining ponds, pools, cellars, drains, building excavations, etc., and for pumping dirty water from septic tanks where the solids in suspension are not greater than 50mm dia., and where water temperature does not exceed 50°C. (please see Pump Features, page 5).

The pump is NOT suitable for pumping salt water, aggressive or chemical substances, or for permanent installation in fish ponds, as the acidity, found in fish ponds, will damage the pump seals. It **MUST NOT** be used for pumping hydrocarbons (petrol, diesel fuel, oils, solvents etc.).

Before using the pump, please read this instruction manual thoroughly and carefully follow all directions given. This is for your own safety and for that of others around you, and will also help you achieve long and trouble free service from your pump.

## GUARANTEE

This product is guaranteed against faults in manufacture for 12 months from purchase date. Keep your receipt as proof of purchase. This guarantee is invalid if the product has been abused or tampered with in any way, or not used for the purpose for which it is intended. The reason for return must be clearly stated. This guarantee does not affect your statutory rights.

**Please note that dismantling this pump will invalidate the guarantee**

## CONTENTS

Guarantee .....	2
Safety Precautions .....	3
Electrical Connections .....	4
Pump Features .....	5
Installation .....	6
Maintenance .....	7
Trouble Shooting .....	8
Pump Specifications .....	9
Parts List and Diagram .....	10
Parts and Servicing .....	11
Declaration of Conformity .....	11



When disposing of this product, do not dispose of with general waste. It must be disposed of according to the laws governing Waste Electrical and Electronic equipment, at a recognised disposal facility.

# SAFETY PRECAUTIONS

1. This pump is designed to pump **WATER ONLY**. Never use for pumping flammable liquids or chemicals of any kind.
2. **NEVER** allow the pump to run dry.
3. An approved Residual Current Device (RCD) **MUST** be used when pumping from ponds or swimming pools.
4. Your submersible pump may **ONLY** be used for pumping water from a swimming pool when there is no person or animal in the pool.
5. **ALWAYS** disconnect the pump from the electrical supply before placing into, or removing from water, and before any cleaning or maintenance.
6. When raising or lowering the pump, **ALWAYS** use a rope or chain attached to the handle. **NEVER** lift or carry the pump by the mains cable or the float switch cable.
7. **DO NOT** run the pump with the body exposed for longer than 10 minutes.
8. **DO NOT** install the pump on sand, silt, mud etc., or ground which is likely to shift.
9. If pumping water which is liable to freeze, the pump **MUST** be run continuously, otherwise the pump must be removed from the water and stored in a frost free location.
10. If the pump is to be used where there may be silt or mud (e.g., garden ponds), **ALWAYS** keep the pump clear of any sediment by standing it on a platform or bricks or suspending from a rope or chain attached to the handle.
11. **DO NOT** use for permanent installation in pumping clean or pure water, (particularly drinking water), as there is the remote risk of contamination, should there be a leak in the seal device.
12. If the mains cable becomes damaged, it **MUST** be replaced - NOT repaired. (see Electrical Installation).
13. If used in a confined space - in a shaft or sump etc., **ENSURE** the float has sufficient room to operate correctly (see Installation on page 6).
14. Connection to the mains supply **MUST** be made well clear of the water, or, if in close proximity, it must be completely waterproofed and secured to prevent the possibility of it coming into contact with water. If necessary consult a qualified technician.

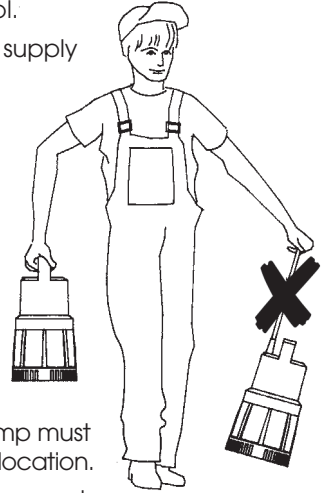

## WARNING

***Failure to comply with these safety precautions could be extremely hazardous, not only causing a risk to personal safety but also damage to the pump, which could invalidate your guarantee.***

# ELECTRICAL CONNECTIONS

The mains lead should be connected to a standard 230Volt (50Hz) electrical supply through an approved 13Amp BS 1363 plug or a suitably fused isolator switch. We recommend that the pump be connected via a Residual Current Device (RCD).

## **IMPORTANT:**

***If used for draining swimming pools or ponds, it is mandatory that the pump be fitted with a Residual Current Device (RCD), with a rated residual operating current of no greater 30mA.***

If the pump is to be connected to an outdoor electrical supply, make sure that both the plug and the socket are of a BS approved waterproof design.

In the event that the pump is hard wired into the electrical system, it must be carried out in accordance with IEE regulations.

## **WARNING: THIS APPLIANCE MUST BE EARTHED**

**IMPORTANT:** The wires in the mains lead are coloured in accordance with the following code:

Green & Yellow	-	Earth
Blue	-	Neutral
Brown	-	Live

As the colours of the flexible cord of this appliance may not correspond with the coloured markings identifying terminals in your plug proceed as follows:

Connect GREEN & YELLOW cord to plug terminal marked with a letter "E" or Earth symbol "⏏" or coloured GREEN or GREEN & YELLOW.

Connect BROWN cord to terminal marked with a letter "L" or coloured RED

Connect BLUE cord to terminal marked with a letter "N" or coloured BLACK

## **FUSE RATING**

The fuse in the plug for this appliance must be rated at **13 amps**.

If this appliance is fitted with a plug which is moulded onto the electric cable (i.e. non-rewirable) please note:

1. The plug must be thrown away if it is cut from the electric cable. There is a danger of electric shock if it is subsequently inserted into a socket outlet.
2. Never use the plug without the fuse cover fitted.
3. Should you wish to replace a detachable fuse carrier, ensure that the correct replacement is used (as indicated by marking or colour code).
4. Replacement fuse covers can be obtained from your local dealer or most electrical outlets
5. The fuse in the plug must be replaced with one of the same rating (**13 amps**) and this replacement must be approved to BS1362.

If the power cable becomes damaged, IT MUST BE REPLACED, DO NOT REPAIR.  
Return the pump to your Clarke dealer, or contact Clarke Service Department on:

**020 8988 7400**

**IMPORTANT:**

**If you are in any doubt regarding electrical installation, you should consult a qualified electrician. DO NOT attempt any electrical repairs yourself.**

## PUMP FEATURES

The pump is of rugged and durable construction, designed for long lasting continuous operation and its' stainless steel body provides good anticorrosive properties. The motor is provided with built in overload protection.

For your information, the chart on page 9 shows the flow rate for the pump at various heads. (HEAD is the distance, or height, from the surface of the water to the point of discharge)

The pump is designed to pump water containing solids in suspension with a maximum diameter of 50mm .

It is NOT designed for permanent installation in fish ponds or any water containing chemicals or other acidic contaminants including salt water.

Whenever the pump is used to pump contaminated water, e.g. to drain septic tanks, fish ponds etc., you must ALWAYS immerse the pump in clean water and run it for a few minutes on completion to ensure it is completely cleansed of all contaminants.

The maximum depth to which the pump should be submerged is 7.4 metres and it will deliver water to a max. head of 7.4 metres

The pump is fitted with a Float Switch and is suitable for permanent or semi-permanent installations, e.g. installations where it is necessary to maintain a water at a particular level.

As the water level rises, so will the float. At a certain point the switch will operate and start the pump. As the water level falls, so will the float until the switch operates again and stops the pump.

Float switches are adjusted at the factory to provide the correct ON-OFF switching mode, however, you can adjust the level at which the pump cuts in and out by sliding the float switch cable through the clip attached to the main body. Shorten or lengthen it as the case may be. The shorter it is, the earlier the pump will cut out, and the water therefore will be deeper at this point. Similarly, it will cut in earlier and the water will therefore be shallower when it does so.

It should not normally be necessary to change the length of cable (from the clamp to the float switch), but should you do so, remember that the cable length should NEVER be so long that the float switch fails to operate and switch the pump OFF. ALWAYS check its operation before use.

Similarly, the cable length must not be so long so as to allow the water level to drop below the level of the outlet pipe.

# INSTALLATION

The pumps' delivery outlet is provided with a 2" BSP female thread, for connection to a suitable adapter (not provided). It is advisable to seal the thread with PTFE, or similar tape, to ensure maximum performance from your pump.

The delivery hose used should be of the same ID as the delivery outlet and completely sound. Any holes, no matter how small, will reduce the efficiency of the pump, or even prevent the pump from delivering water at all. Smaller diameter hose will reduce capacity and put additional strain on the motor.

Where it is necessary for long horizontal stretches of delivery hose to be used, the hose ID should be greater than that of the delivery outlet.

Having connected the delivery hose, secure a suitable length of rope or chain to the pump handle, and plunge the pump into the water.

The pump must be in a vertical position on a solid flat surface. If this is not available, sit the pump on house bricks, or something similar, and ensure that this type of support is not likely to shift.

The pump should be well clear of silt, mud or any type of marine growth.

## IMPORTANT:

**ALWAYS** raise and lower the pump using a rope attached to the lifting handle, **NEVER** by the power cable.

Ensure the sump, or bore hole, has adequate dimensions so as not to restrict the movement of the float switch (see fig.1 for recommended minimum size).

The calculation, for the dimensions of the bore hole, must also take into account the quantity of water arriving and the pump flow rate, so as not to subject the motor to excessive starting operations, bearing in mind, **the pump should not be started more than 20 times per hour.**

Take all necessary precautions as described on page 4 before plugging in, and switching ON.

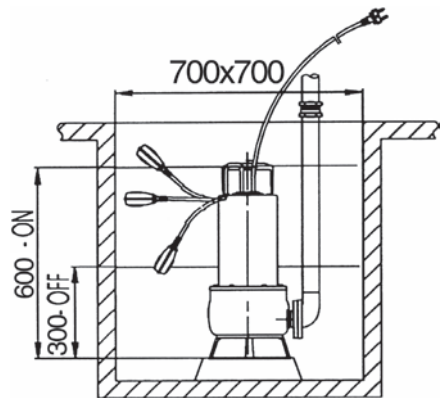

Fig.1

## NOTE:

- The symbol  $\sphericalangle$  on the pumps' Rating Plate, denotes the MAXIMUM depth to which the pump may be submerged, in metres.*
- When the pump is used in a permanent or semi-permanent installation, a check valve MUST be fitted in the delivery pipe.*

**IMPORTANT:** In such situations, care must be taken to ensure that all air is expelled from the delivery side of the pump when immersing in water.

# MAINTENANCE

## **WARNING**

***Before checking the condition of the pump, ensure it is unplugged from the mains supply. If the unit is hard wired, ensure the circuit breaker is open.***

The pump should require no maintenance other than regular cleaning. Its' mechanical seal is lubricated in an oil chamber, and its' bearings are 'sealed for life'. If the pump starts to show signs of wear or damage, contact your CLARKE dealer for advice. Do not use the pump if there is any damage to the mains supply cable, or to the float switch or its cable.

Check the pump installation regularly to ensure the base inlet is clear of leaves or other debris.

Note that the pump is fitted with automatic thermal overload protection. If it overheats due to an obstruction in the pump, or pumping warm water in excess of 50°C for example, it will shut off automatically. Switch the pump OFF and disconnect from the mains supply. Check for blockages and allow the motor to cool (at least 15 minutes) before attempting to restart.

Do not attempt to repair the pump yourself, as you may damage the seals and invalidate your guarantee. Repairs must be carried out by a qualified pump engineer, your CLARKE dealer, or contact the CLARKE Service Department, on:

**020 8988 7400**

If the pump becomes badly clogged, backflush the pump chamber by directing a jet of clean water through the outlet port. If you remove the outlet port adapter when you perform this operation, take the opportunity to inspect the impeller for wear or damage, viewing it through the outlet port.

## **WARNING:**

***Do not attempt to strip the pump further as this will invalidate the guarantee***

**ANNUALLY OR EVERY 2000 WORKING HOURS** (Whichever is sooner)

The sealing oil must be checked by a qualified pump engineer. Consult your Clarke dealer, or Clarke International Service Department.

**SUITABLE HOSE AND HOSE ADAPTERS  
ARE AVAILABLE FROM YOUR CLARKE DEALER**

# TROUBLE SHOOTING

## A. PUMP WILL NOT START

1. Check to ensure Power is switched on.
2. Check fuse (consult an electrician if in doubt).
3. If extension lead is fitted, check connections (consult an electrician if in doubt).
4. Internal thermal cutout has not reset. Leave for 15 minutes and try again.
5. The Impeller may be jammed. Disconnect from the mains supply, remove the bottom strainer and outlet connection. Remove any objects that may be obstructing the impeller. Replace the strainer and try again.
6. Float switch may be jammed against side wall or prevented from moving.
7. Water level too low - float switch in OFF position - Lift float to check switch.

If the pump still fails to start, consult your CLARKE dealer for advice.

## B. PUMP WILL START BUT NOT PUMP

1. Check to ensure strainer is not blocked - clean as necessary
2. Discharge tube clogged or obstructed - clear as necessary.
3. The head may be too great, i.e. you are trying to lift the water too great a distance for the pump to cope with. (See specifications pages 9).
4. Impeller may be damaged - Consult your CLARKE dealer

## C. PUMP WILL NOT STOP

1. Float switch may be prevented from moving to the fully down position.
2. Float switch may be faulty. Consult your CLARKE dealer for advice.

## D. PUMP STOPS RUNNING

1. Thermal overload has operated. If this condition persists, investigate the cause. Are you attempting to pump liquid which is too dense for the pump (mud, slurry etc.), or too high a temperature.
2. Pump has run dry, or float switch has cut in.
3. A foreign object has jammed the impeller.



# SPECIFICATIONS

Motor .....	230 V 50Hz 1ph
Motor Rating (Nominal -Output) .....	927 W
Input Current .....	4.13 Amps
Fuse Rating .....	13 Amps
Outlet Connection .....	2" BSP Female
Head Max. ....	7.5m
Max. Submersion Depth .....	7.5m
Max. Capacity .....	330 l/min
Max. Water Temperature .....	50°C
Weight (unpacked) .....	11.7 kg
Cable Length .....	10 m
Part No. ....	7230091

## WARNING!

Connection to the mains supply **MUST** be made well clear of the water, or, if in close proximity, it must be completely waterproofed and secured to prevent the possibility of it coming into contact with water. If necessary consult a qualified technician.

Fig.2

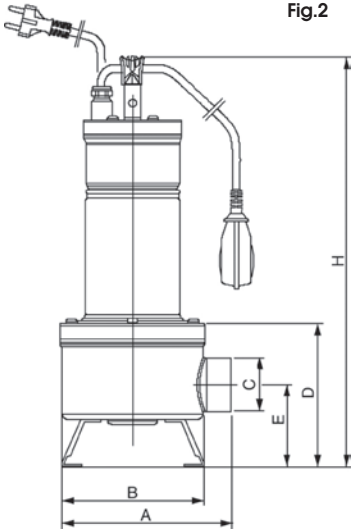

A - 203mm	D - 172mm
B - 170mm	E - 98mm
C - 2" BSP	H - 492mm

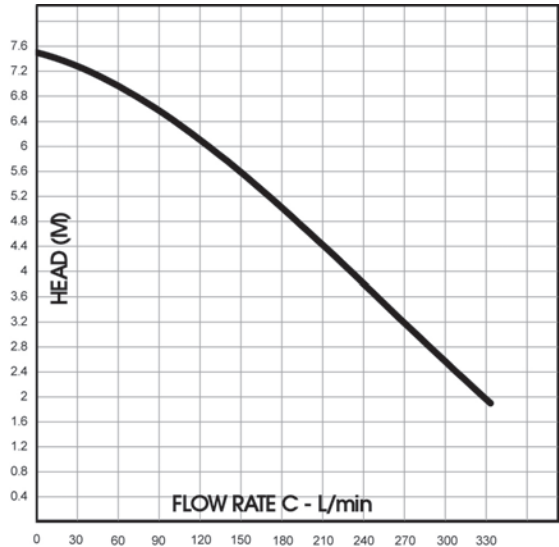

# Parts List and Diagram

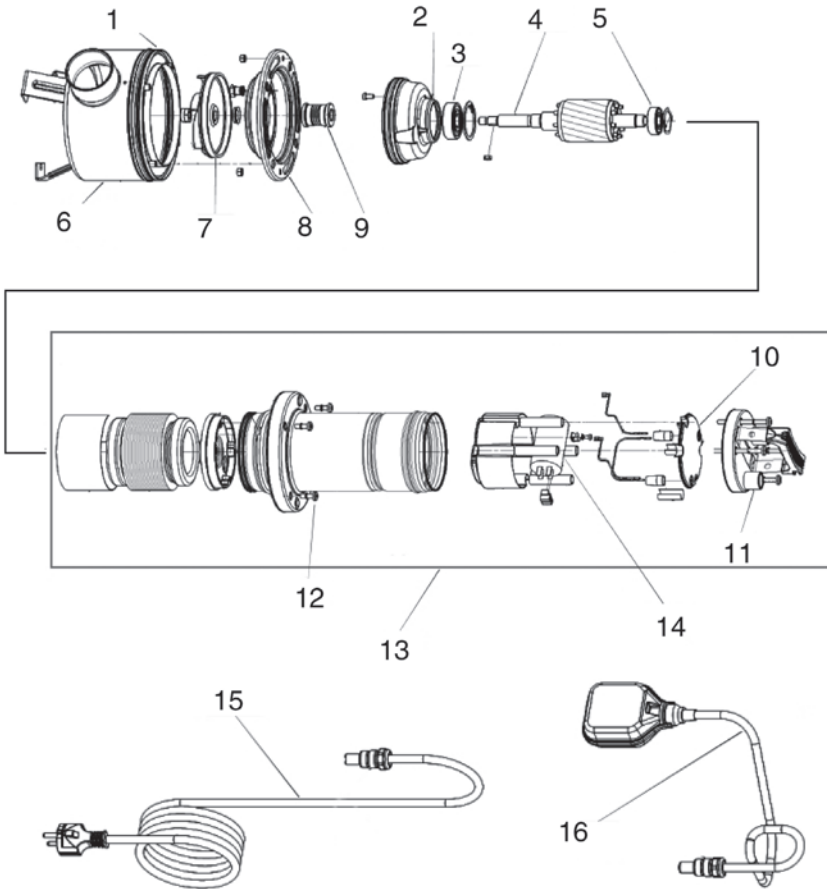

Item	Description	Part No	Item	Description	Part No
1	OR/Seals	DABR00004190	9	Seal	DABR00004133
2	Bearing Support	DABR00004134	10	Cables Cover	DABR00004135
3	Front Bearing	DABR00004129	11	Cover	DABR00004137
4	Motor Shaft	DABR00004126	12	Nuts and Bolts	DABR00004128
5	Rear Bearing	DABR00004130	13	Motor	DABR00004191
6	Pump Body	DABR00004125	14	Capacitor	DABR00004140
7	Impeller	DABR00004131	15	Cable	DABR00004139
8	Seal Disk	DABR00004192	16	Float	DABR00004138

## Parts & Servicing

For Parts & Servicing, please contact your nearest dealer, or  
CLARKE International, on one of the following numbers.

**PARTS & SERVICE TEL: 020 8988 7400**

**PARTS & SERVICE FAX: 020 8558 3622**

or e-mail as follows:

**PARTS: parts@clarkeinternational.com**

**SERVICE: service@clarkeinternational.com**

## Declaration of Conformity

<p style="text-align: center;"><b>Clarke</b> INTERNATIONAL</p> <p style="text-align: center;"><b>This is an important document, and should be retained.</b></p> <p style="text-align: center;"></p> <p style="text-align: center;"><b>DECLARATION OF CONFORMITY</b></p> <p style="text-align: center;">We declare that this product complies to the following standards/directives:</p> <p style="text-align: center;">■ <b>98/37/EC</b></p> <p>Product Description: <b>SUBMERSIBLE PUMP</b></p> <p>Model No: <b>ISP11A</b></p> <p>Serial (Batch) No: <b>See Product Data Plate</b></p> <p>Signed  Mr. D Kemp Engineering Manager</p> <p style="text-align: center;"><b>Clarke</b> INTERNATIONAL Hemnal Street, Epping, Essex CM16 4LG</p> <p style="text-align: right;">JANUARY, 2008</p>
--

Clarke International is a trading style of Clarke International Limited

A SELECTION FROM THE VAST RANGE OF

# Clarke®

## QUALITY PRODUCTS

### **AIR COMPRESSORS**

*From DIY to industrial. Plus air tools, spray guns and accessories.*

### **GENERATORS**

*Prime duty or emergency standby for business, home and leisure.*

### **POWER WASHERS**

*Hot and cold, electric and engine driven - we have what you need.*

### **WELDERS**

*Mig, Arc, Tig and Spot. From DIY to auto/industrial.*

### **METALWORKING**

*Drills, grinders and saws for DIY and professional use.*

### **WOODWORKING**

*Saws, sanders, lathes, mortises and dust extraction.*

### **HYDRAULICS**

*Cranes, body repair kits, transmission jacks for all types of workshop use.*

### **WATER PUMPS**

*Submersible, electric and engine driven for DIY, agriculture and industry.*

### **POWER TOOLS**

*Angle grinders, cordless drill sets, saws and sanders.*

### **STARTER/CHARGERS**

*All sizes for car & commercial use.*



## Clarke INTERNATIONAL

For spare parts and servicing, please contact your nearest dealer, or Clarke International on

**020 - 8988 - 7400**

e-mail: [Parts@clarkeinternational.com](mailto:Parts@clarkeinternational.com) e-mail: [Service@clarkeinternational.com](mailto:Service@clarkeinternational.com)

**Hemnal Street, Epping, Essex CM16 4LG**