

Charlton®

STRONG-ARM



3 TONNE TROLLEY JACK

MODEL NO: CTJ3QLGB

PART NO: 7621000

OPERATION & MAINTENANCE INSTRUCTIONS

UK
CA | CE

ORIGINAL INSTRUCTIONS

DL1021

INTRODUCTION

Thank you for purchasing this CLARKE Trolley Jack.

Before attempting to use this product, please read this manual thoroughly and follow the instructions carefully. In doing so you will ensure the safety of yourself and that of others around you, and you can look forward to your purchase giving you long and satisfactory service.

SPECIFICATIONS

Model number	CTJ3QLGB
Length (not including handle):	616 mm
Width	360 mm
Overall Height (not including handle):	300 mm
Height of Saddle from Floor (min. - max.)	135 mm - 510 mm
Weight	36.2 kg
Rated Load	3 tonne (3000kg)
Pump Oil Capacity	0.23 L
Number of Strokes to Max. Height	Handle Only: 22 With Foot Pedal: 10

GUARANTEE

This product is guaranteed against faulty manufacture for a period of 12 months from the date of purchase. Please keep your receipt which will be required as proof of purchase.

This guarantee is invalid if the product is found to have been abused or tampered with in any way, or not used for the purpose for which it was intended.

Faulty goods should be returned to their place of purchase, no product can be returned to us without prior permission.

This guarantee does not effect your statutory rights.

SAFETY PRECAUTIONS



WARNING: THE OPERATOR MUST FOLLOW ALL INSTRUCTIONS WITHIN THIS INSTRUCTION BOOKLET

1. **ALWAYS** wear protective footwear when using a trolley jack.
1. This jack is for lifting only, **DO NOT** move a load using the jack as a dolly.
2. **DO NOT** use to lift people.
3. **ALWAYS** inspect the jack before use. Make sure that all parts are in good condition and operating smoothly, and that no cracks or distortion is apparent. If in doubt **DO NOT** use. Have the damaged parts replaced or consult your CLARKE dealer.
4. Make sure that the jack is on a firm level base, and there is no possibility of it slipping when under load.
5. Make sure the load is taken by the full saddle and that the point of lift on the load, is strong enough to support the load adequately.
6. **DO NOT** work under the raised vehicle until it is supported by suitable means e.g. axle stands, **NEVER** rely on the jack to support the vehicle by itself.
7. **NEVER** push a load off the jack.
8. Ensure that all personnel are well clear of a load being raised or lowered.
9. **DO NOT** try to lift more than the rated load for the jack.
10. **DO NOT** use the jack if an oil leak is apparent. Consult your CLARKE dealer.
11. Consult the vehicle handbook to determine the correct lifting points.
12. It is necessary that the operator watch the jack and the load during operation.
13. Check the condition of the labels regularly and replace as required.
14. The jack must be maintained and repaired in accordance with these instructions by suitably qualified persons.
15. **DO NOT** make any modifications to this jack or adjust any valves.

UNPACKING AND ASSEMBLY

1. Connect the two halves of the Operating Handle and secure with the locking pin.

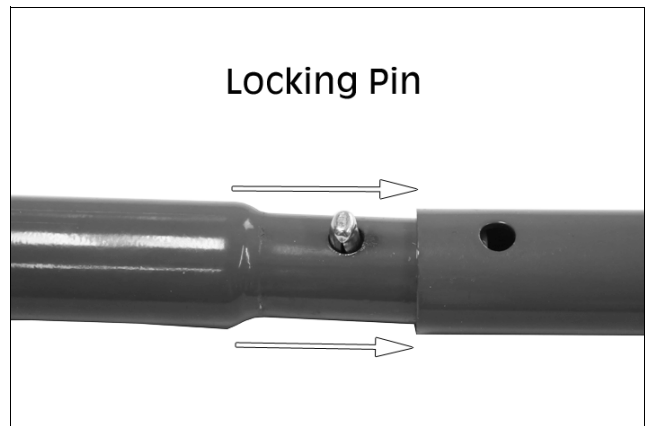

2. Remove the packing/storage clip shown.

NOTE: DO NOT dispose of packing/storage clip, as this is needed for access to the oil plug, see page 7.

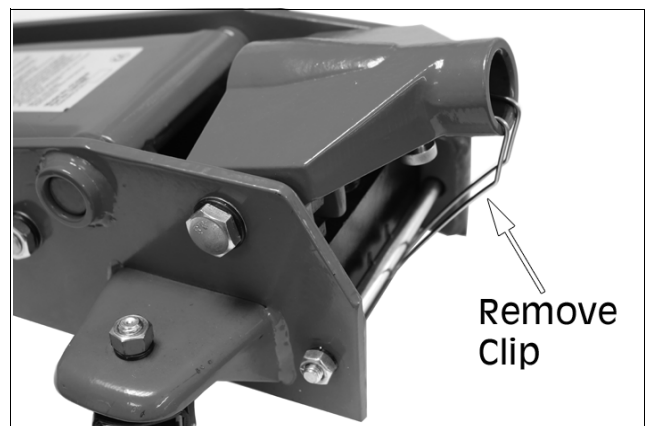

3. Loosen the locating screw from the rear of the handle housing shown and insert the handle into the housing, ensuring the square drive on the end of the handle, engages fully with the square spigot within the housing.

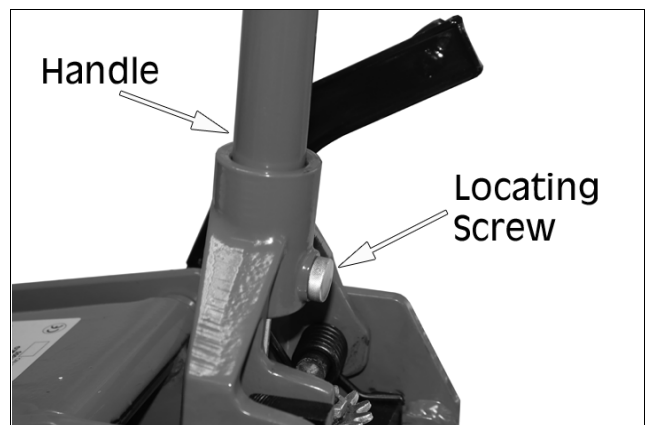



4. Tighten the locating screw.

5. Place the foot pedal on the socket located on the side of the jack and tighten the locking bolt (M5 x 12mm).

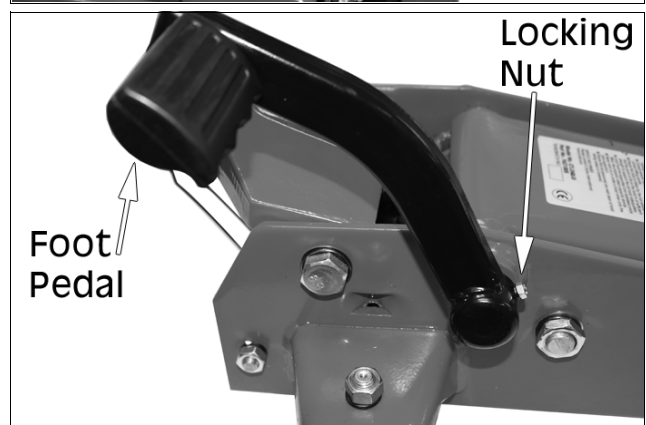
NOTE: The foot pedal can be used with the handle to pump up the jack. It will give you approximately twice the rise height per pump than the handle alone.

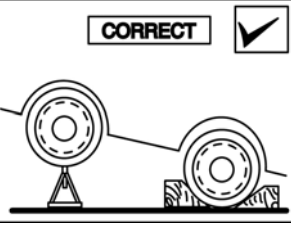
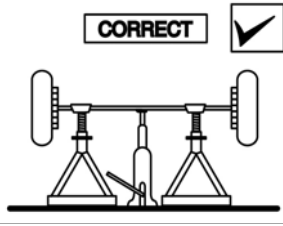
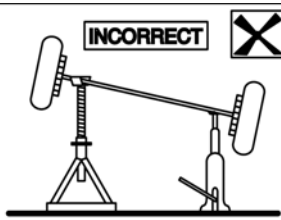
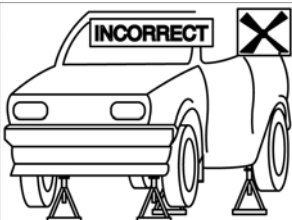

SAFETY SYMBOLS

	<p>Always read manual fully before use.</p>		<p>Always wear protective footwear</p>
	<p>Always chock wheels</p>		<p>Always lift from the central jacking point (See vehicle manual for location)</p>
	<p>Never use a single axle stand and jack to support the vehicle</p>		<p>Never support the vehicle on 4 axle stands</p>

FIRST TIME OPERATION & PURGING AIR FROM THE SYSTEM

If air bubbles become trapped inside the hydraulic system during shipping or transport, the efficiency of the jack will be reduced and the jack will feel spongy.

1. Turn the control handle counter-clockwise, relieving the pressure inside the jack.
2. Pump the handle several strokes to purge air from the system.
3. Turn the control handle clockwise and pump to raise the jack to its full height. Pump the handle again several full strokes.
4. Test the jack and if efficiency is still low, repeat the above procedure with the oil filler plug loosened. Check the oil level as described under Maintenance section on page 7.
5. The jack is now ready to use.

OPERATION

Before use, inspect the jack for oil leaks or any other sign of damage. Should any be apparent, have the jack repaired by a qualified technician.



WARNING: NEVER WORK ON THE VEHICLE WHEN SUPPORTED ONLY BY A JACK. THIS IS HIGHLY DANGEROUS. THE VEHICLE SHOULD BE SUPPORTED ON AXLE STANDS OR SUITABLE SUPPORTS, BENEATH THE CORRECT JACKING/SUPPORT POINTS.

1. Ensure the vehicle to be raised is stable and on firm level ground with the wheels chocked.
2. To ensure safe lifting, position the jack at a 90° angle to the vehicle and under the appropriate jacking point.
 - Consult the vehicle handbook to determine suitable jacking points.
3. Twist the handle clockwise until it stops to close the control valve.
4. Pump the handle to raise the saddle is in contact with the jacking point.
5. Make sure that the saddle is in full contact with the lifting point and that there is nothing that will prevent a clean lift. Keep all personnel at a safe distance before lifting the vehicle.
6. Continue pumping the handle until the vehicle is at the required height.
 - **CAUTION:** Observe the vehicle carefully during the lifting operation. The jack should move in the direction of the vehicle during lifting. Should this not be the case, there is a strong possibility that the vehicle will slide off the jack.
7. Position axle stands directly beneath suitable supporting points on the vehicle and very gently twist the handle anti-clockwise.
8. This will open the control valve to lower the load onto the stands.
 - Make sure that the axle stands are in good condition and that they can hold the load.
9. Ensure that the axle stands cannot move when supporting the load. Use suitable wheel chocks to stop the vehicle from moving.

NOTE: The jack may move slightly during operation. It is important therefore, that the floor is clean and completely free from debris.
10. To stop it lowering at any point, turn the handle clockwise again. Always avoid a rapid descent by turning the handle slowly.
11. Carefully lower the vehicle onto the axle stand, checking constantly, preferably with an assistant, that the vehicles jacking point rests snugly and

cleanly on the axle stand, and that the stand is stable before the weight is taken.

NOTE: Ensure this operation is carried out under complete control. **DO NOT** allow the load to drop suddenly as this could damage internal parts.

12. Completely remove the jack from the vehicle.

MAINTENANCE

CHECKING /MAINTAINING THE OIL LEVEL

If the jack has been stored for long periods, check for oil leaks before use. If necessary, check the oil level as follows:

1. Ensure the jack is fully lowered by turning the control valve fully anti-clockwise.
2. Remove handle and attach the packing/storage clip.
3. Remove the oil plug.
 - The oil should be almost level with the bottom of the oil filler hole.
 - Oil can be topped up using CLARKE Hydraulic Oil (p/n 3050830 1 litre).
4. Purge any air from the system and replace the oil plug.
5. Dispose of old/spilled oil appropriately and wipe up any spillage.

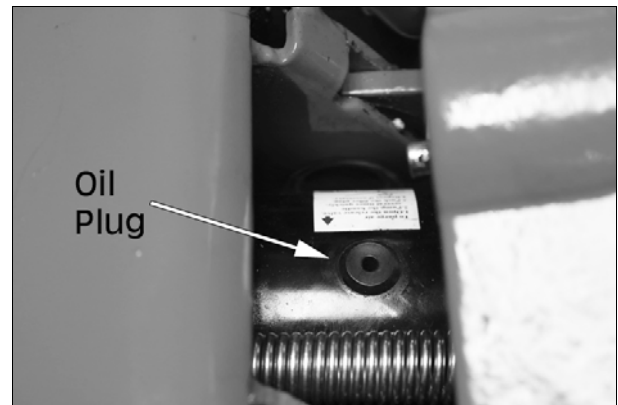

GENERAL CARE

1. Periodically lubricate the hinges, front wheels & rear castors with light oil.
2. Store in a dry location, with the ram fully retracted.
3. In the event of damage or broken components **DO NOT USE**, replacements are available from CLARKE Parts & Service.

ENVIRONMENTAL PROTECTION

One of the most damaging sources of environmental pollution is oil products. Never throw away used hydraulic oil with domestic refuse or flush it down a sink or drain. Collect any hydraulic oil in a leak proof container and take it to your local waste disposal site.



If disposing of this product or any damaged components, do not dispose of with general waste. This product contains valuable raw materials and should be taken to your local civic amenity site for recycling of metal products.



TROUBLESHOOTING

PROBLEM	CAUSE	SOLUTION
The lifting arm won't raise when pumping under load.	Check whether the drain valve is fully closed.	Close it by rotating the handle clockwise.
	Low oil level in the pump.	Check the oil level by placing the trolley jack in a horizontal position.
		Top up the hydraulic oil and purge the hydraulic system - See "Checking and Maintaining the Oil Level" section on page 7.
The lifting arm is sinking under load.	As Above	Follow the instructions provided for previous problem. Should this still not eliminate the fault, the trolley jack needs to be repaired by an authorised repairer.
The lifting arm can't be lowered.	The tension spring for the lifting arm has unhooked or broken.	Re-hook the spring or replace the broken spring with an equivalent new spring.
	The trolley jack presumably needs lubricating.	All moving parts must be cleaned and lubricated or greased (see Instructions for use). IMPORTANT: The rods of the pumping and lifting cylinder should NEVER be lubricated or greased.
	Too much oil in the hydraulic system.	Screw out the drain valve and drain out the excess oil - See "Checking and Maintaining the Oil Level" section on page 7.

If any of these remedies fail to restore your jack, consult your CLARKE dealer.

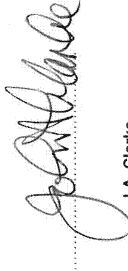
DECLARATION OF CONFORMITY

	 Clarke[®] INTERNATIONAL Fitzwilliam Hall, Fitzwilliam Place, Dublin 2
DECLARATION OF CONFORMITY This is an important document and should be retained.	
<p>We hereby declare that this product(s) complies with the following directive(s): 2006/42/EC Machinery Directive.</p>	
<p>The following standards have been applied to the product(s): EN 1494:2000 + A1:2008</p>	
<p>The technical documentation required to demonstrate that the product(s) meet(s) the requirement(s) of the aforementioned directive(s) has been compiled and is available for inspection by the relevant enforcement authorities.</p>	
The CE mark was first applied in: 2021	
Product Description:	3 Tonne Quick Lift Jack
Model number(s):	CTJ3QLGB
Serial / batch Number:	N/A
Date of Issue:	18/10/2021
Signed:	 J.A. Clarke Director

	 Clarke[®] INTERNATIONAL Hemncoll Street, Epping, Essex CM16 4LG
DECLARATION OF CONFORMITY This is an important document and should be retained.	
<p>We hereby declare that this product(s) complies with the following statutory requirement(s): Supply of Machinery (Safety) Regulations 2008</p>	
<p>The following standards have been applied to the product(s): EN 1494:2000 + A1:2008</p>	
<p>The technical documentation required to demonstrate that the product(s) meet(s) the requirement(s) of the aforementioned legislation has been compiled and is available for inspection by the relevant enforcement authorities.</p>	
The UKCA mark was first applied in: 2021	
Product Description:	3 Tonne Quick Lift Jack
Model number(s):	CTJ3QLGB
Serial / batch Number:	N/A
Date of Issue:	18/10/2021
Signed:	 J.A. Clarke Director

COMPONENT PARTS - GENERAL ASSEMBLY

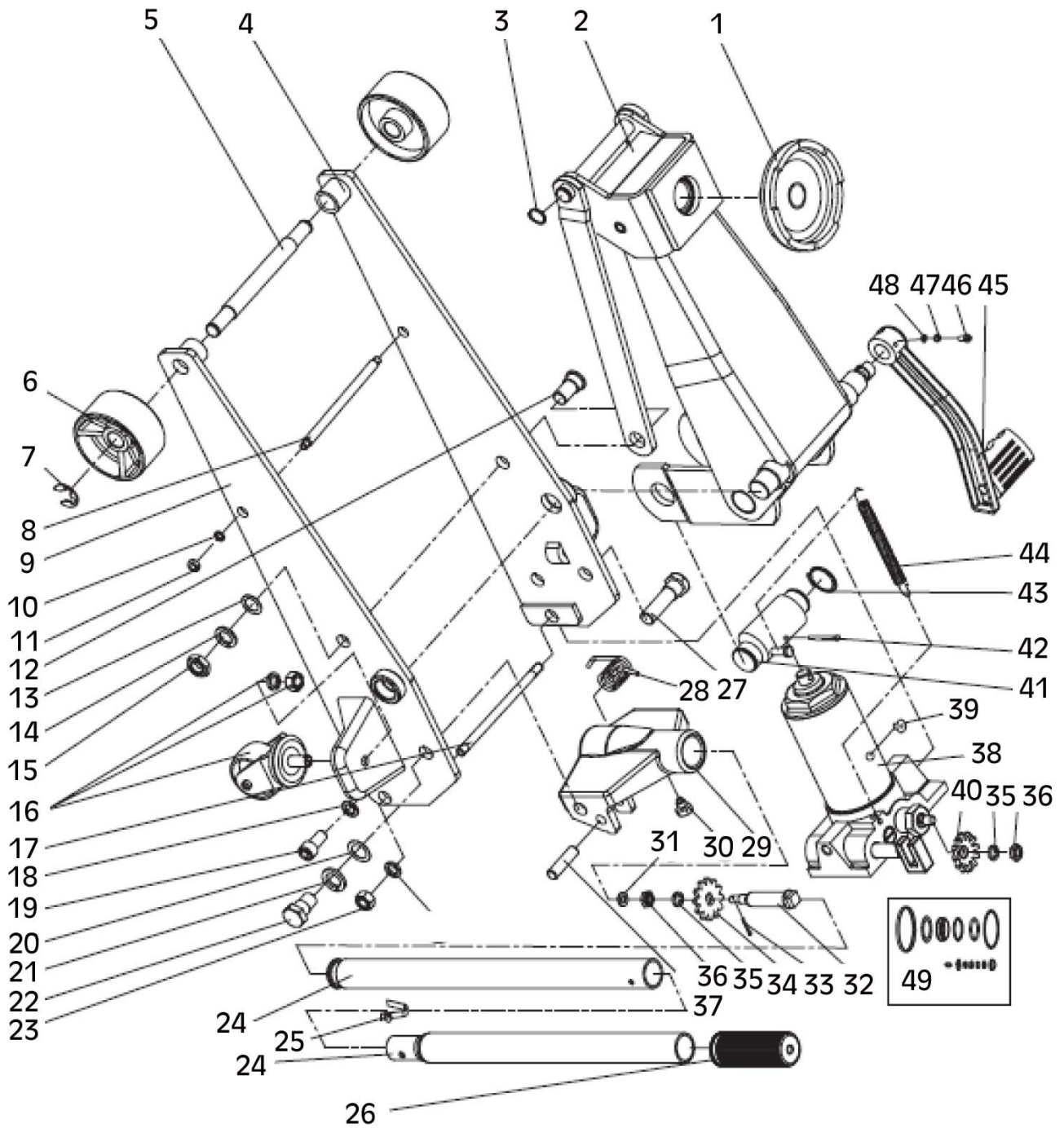

COMPONENT PARTS - GENERAL ASSEMBLY

No	Description
1	Saddle
2	Lifting Arm Assembly
3	C-Clip Ø18mm
4	Right Frame Assembly
5	Shaft for Front Wheel
6	Front Wheel
7	Side-mount External Retaining Ring Ø15mm
8	Connected rod
9	Left Frame Assembly
10	Spring Washer M8
11	Nut M8
12	Connecting Rod Pintle
13	Washer M16
14	Spring Washer M16
15	Nut M16
16	Rear Caster Assembly M12
17	Back Shaft
18	Spring Washer M12
19	Socket Head Cap Screw M12 x 25mm
20	Washer M18
21	Spring Washer M18
22	Shoulder Bolt M18 x 35.5mm
23	Nut M12
24	Handle Assembly
25	Handle Lock Pin

No	Description
26	Handle Cover
27	Shoulder Bolt M18 x 66.5mm
28	Torsion Spring
29	Handle Socket
30	Handle Socket Screw M10 x 19mm
31	Washer M8
32	Shaft for Spur Gear
33	Cotter Pin Ø2 x 16mm
34	Spur Gear
35	Spring Washer M10
36	Nut M10
37	Pump Plunger Pin
38	Power Unit Assembly
39	Oil Plug
40	Helical Gear
41	Coupling Connector
42	Cotter Pin Ø4 x 45mm
43	C-Clip Ø30mm
44	Return Spring
45	Foot Pedal Assembly
46	Hex Bolt M5 x 12mm
47	Spring Washer M5
48	Washer M5
49	Seal Kit

A SELECTION FROM THE VAST RANGE OF

Clarke®

QUALITY PRODUCTS



AIR COMPRESSORS
From DIY to industrial, Plus air tools,
spray guns and accessories.

GENERATORS
Prime duty or emergency standby
for business, home and leisure.

POWER WASHERS
Hot and cold, electric and engine
driven - we have what you need

WELDERS
Mig, Arc, Tig and Spot.
From DIY to auto/industrial.

METALWORKING
Drills, grinders and saws for DIY
and professional use.

WOODWORKING
Saws, sanders, lathes, mortisers
and dust extraction.

HYDRAULICS
Cranes, body repair kits,
transmission jacks for all types of
workshop use.

WATER PUMPS
Submersible, electric and engine driven
for DIY, agriculture and industry.

POWERTOOLS
Angle grinders, cordless drill sets,
saws and sanders.

STARTERS/CHARGERS
All sizes for car and commercial use.



PARTS & SERVICE: 0208 988 7400

Parts Enquiries
Parts@clarkeinternational.com

Servicing & Technical Enquiries
Service@clarkeinternational.com

SALES: UK 01992 565333 or Export 00 44 (0)1992 565335

Clarke® INTERNATIONAL Hemnall Street, Epping, Essex CM16 4LG
www.clarkeinternational.com