

MAINTENANCE

Daily.

Inspect for distortion of components, and security of all nuts and bolts. If in doubt, do not use. Have damaged parts repaired or replaced. If necessary, consult your CLARKE dealer.

Every 6 months

Remove the top cover by unscrewing the cover securing screws (the covers on the 5 and 10 Tonne models, hinge back towards the handle), and inspect thoroughly for cracks or distortion of the components, and security of all nuts and bolts. If in doubt, do not use. Have damaged parts repaired or replaced.

Lubricate all parts and check for oil leaks. If a slight oil seepage is evident, check the ram oil level, by removing the filler plug, directly on top of the ram. The oil should be level with the bottom of the filler orifice. If necessary, top up with CLARKE HYDRAULIC OIL. (See your CLARKE dealer. For 1 litre bottle quote Part No. 3050830.)

If the leak is more pronounced, DO NOT use the jack....consult your CLARKE dealer.

Grease the points shown in Fig.1..Castor Assembly's, Front Wheels (except for the 3 Tonne model which is not provided with grease points at the front wheels), and pivot point.

Storage

Store in a dry place where it cannot be attacked by the elements. If stored for long periods, inspect at least twice a year, clean and re-oil. For servicing, contact your CLARKE dealer, or CLARKE International Service Dep't.

SPECIFICATIONS

Model No.	CTJ3GLC (3tonne)	CTJ5GLC (5tonne)	CTJ10GLC (10tonne)
Maximum load (Tonnes)	3	5	10
Minimum Height (mm)	130	150	170
Maximum Height (mm)	610	570	585
Overall Length (mm)	1415	1405	1545
Overall Width	340	375	460
Weight (kg/lbs)	80/176	102.5/225	148/325
Part No.	7621030	7621035	7621040

SPARE PARTS

The following user serviceable parts are available from your Clarke dealer, or Clarke International Parts Dept.

1. Saddle
2. Castor Assembly
3. Front Wheel Assembly
4. Release Valve Operating Lever

For Spare Parts and Servicing, please contact your nearest dealer, or CLARKE International, on one of the following numbers.

PARTS & SERVICE TEL: 020 8988 7400
PARTS & SERVICE FAX: 020 8558 3622

ClarkeTM STRONG-ARM

3, 5 & 10 tonne LONG REACH TROLLEY JACK

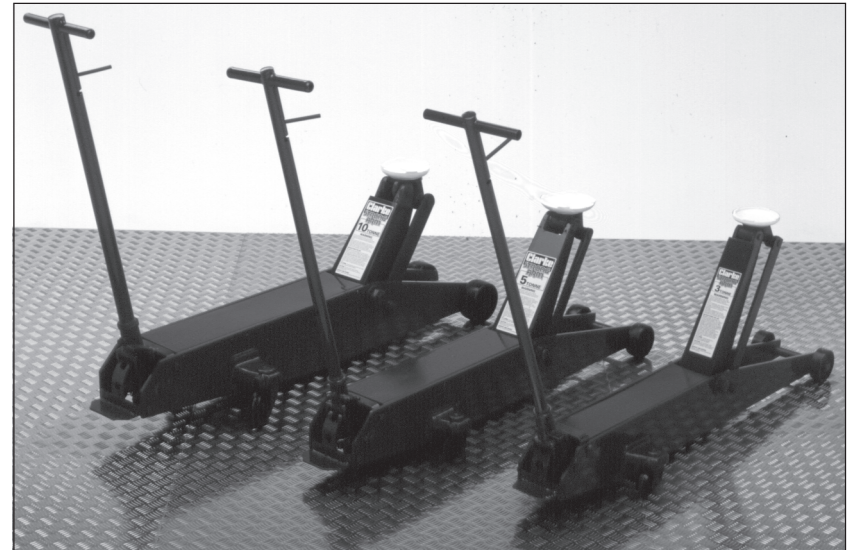

Model Nos. CTJ3GLC, CTJ5GLC & CTJ10GLC

GUARANTEE.

This CLARKE product is guaranteed against faulty manufacture for a period of 12 months from the date of purchase. Please keep your receipt which will be required as proof of purchase.

This guarantee is invalid if the product is found to have been abused in any way, or not used for the purpose for which it was intended. Faulty goods should be returned to their place of purchase, no product can be returned to us without prior permission.

This guarantee does not effect your statutory rights.

Thank you for purchasing this Clarke Long Reach Trolley Jack.

Before attempting to use the unit, please read this instruction booklet thoroughly, and follow all directions carefully, paying particular attention to the safety precautions. By doing so, you will ensure the safe operation of the unit, and the safety of yourself and others around you. You can then look forward to long and reliable service from your CLARKE Trolley Jack.

SAFETY PRECAUTIONS

1. This jack is for lifting ONLY..DO NOT move a load using the jack as a dolly
2. Always inspect the jack before use. Ensure that all parts are in good condition and operating smoothly, the wheels are sound and that no cracks or distortion is apparent. If in doubt **do not use**. Have the parts replaced or consult your CLARKE dealer.
3. Ensure the jack is on a firm solid base, and that there is no likelihood of it slipping when under load.
4. Ensure the load is taken by the **FULL** saddle and that the point of lift on the load, is of sufficient strength to support the full load adequately.
5. Always ensure that the load is stabilised or supported in such a way that it will not shift during lifting or lowering operations.
6. Always use supports to stabilise the load once lifted. **NEVER** work on or under a load unless it is fully and adequately supported. **NEVER** rely upon the jack to hold the load in position.
7. Never push a load off the jack.
8. Ensure that all personnel are well clear of a load being raised, or lowered.
9. NEVER exceed the rated load for the jack (see 'Specifications').
10. Do not use if an oil leak is apparent...Consult your Clarke dealer.

FITTING THE JACK HANDLE

Remove the bolt, at the rear of the jack handle housing, sufficient for the handle to be inserted fully, with the Release Valve Operating Lever facing forward (see Fig.1).

Replace the bolt so that it locates in the hole provided in the handle shaft, and tighten fully.

OPERATION

POSITIONING THE JACK

For ease of positioning, the jack handle may be locked in three different positions... vertically...horizontally...and a mid-position. This is achieved as follows:

3 tonne model:

To lock the handle in place, move it roughly to the desired position, i.e. vertically, horizontally, or mid-position then push the valve operating lever downwards as far as possible. Move the handle forwards or backwards slightly until the locking bar engages in the locating hole at the base of the handle. This action will be felt at the lever, which may now be moved sideways so that it engages in the bottom slot, thereby locking the handle in place. To release the handle, disengage the lever from the bottom slot.

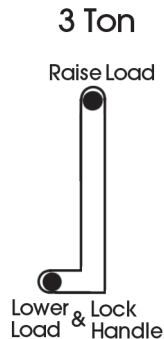

5 and 10 tonne models:

When at rest, the locking mechanism will automatically lock the handle in one of the three positions. To release the handle, raise the lever and engage it in the upper slot.

To lock the handle in any particular position, raise the operating lever and hold it, against spring pressure, in order to disengage the locking mechanism. Move the handle to the desired position and release the valve operating lever so that it reasserts to the bottom of the slot. The locking bar will automatically snap into the locating hole when the components line up. To release the locking mechanism again, simply lift the operating lever, and to prevent the locking mechanism from operating, turn the lever sideways so that it engages in the upper slot.

5 & 10 Ton

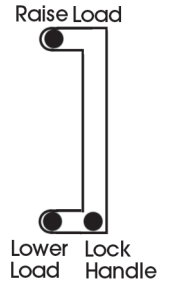

RAISING AND LOWERING

Ensure the load is chocked and stable and on firm level ground, before manoeuvring the jack so that the saddle is directly beneath the lifting point.

3 tonne model.

To raise the saddle, allow the lever to remain in the 'UP' position and pump the handle.

To lower the load, follow all precautions to ensure that there are no obstacles that could prevent the load from lowering without hindrance, and that all personnel are well away from the site, before pushing the lever down, and VERY GENTLY turning it sideways, so that it enters the lower slot. This will open the release valve and allow the load to drop. The more you turn the lever, the faster the rate of descent. DO NOT jerk the lever sideways...ALWAYS lower the load under complete control.

5 and 10 tonne models:

In order to raise the saddle, lift the operating lever and turn sideways so that it engages in the upper slot, thereby locking the lever in the 'up' position. Pumping the handle, or alternatively the foot pedal, adjacent to the base of the handle, will cause the saddle to rise.

IMPORTANT:

The foot pedal is used to quickly bring the saddle to the lifting point, NOT to raise a load.

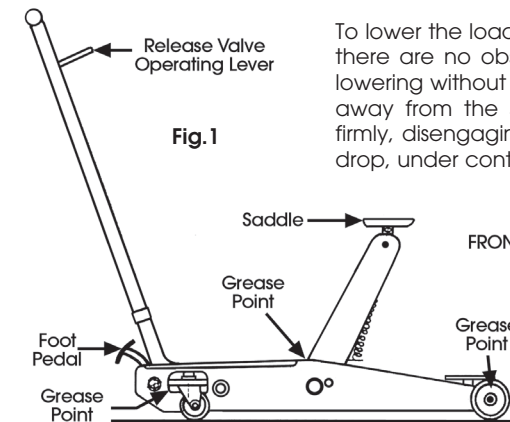

To lower the load, first make one final check to ensure that there are no obstacles that could prevent the load from lowering without hindrance, and that all personnel are well away from the site, before gripping the operating lever firmly, disengaging it from the upper slot and allowing it to drop, under control to the bottom of the vertical slot.

VERY GENTLY, turn the lever sideways, so that it enters the lower slot, thereby opening the release valve and allowing the load to drop. The more you turn the lever, the faster the rate of descent. DO NOT jerk the lever into the lower slot...ALWAYS lower the load under complete control.