

# Clariflo®



## DESKTOP MAGNIFYING LAMP MODEL NO: TML89

PART NO: 5460512

## OPERATING INSTRUCTIONS



ORIGINAL INSTRUCTIONS

GC0117

---

## INTRODUCTION

---

Thank you for purchasing your CLARKE desktop magnifying lamp, which is ideal for fine detail assembly and repair work, stamp collectors, model makers, jewellers, etc.

Before using this product, read this leaflet thoroughly, and follow the instructions carefully. Although the product is robust it should nevertheless be used with care and consideration, you can then look forward to it giving long and reliable service.

---

## GUARANTEE

---

This product is guaranteed against faulty manufacture for a period of 12 months from the date of purchase. Please keep your receipt which will be required as proof of purchase.

This guarantee is invalid if the product is found to have been abused or tampered with in any way, or not used for the purpose for which it was intended.

Faulty goods should be returned to their place of purchase, no product can be returned to us without prior permission.

This guarantee does not effect your statutory rights.

---

## ENVIRONMENTAL RECYCLING POLICY

---



Through purchase of this product, the customer is taking on the obligation to deal with the WEEE in accordance with the WEEE regulations in relation to the treatment, recycling & recovery and environmentally sound disposal of the WEEE.

In effect, this means that this product must not be disposed of with general household waste. It must be disposed of according to the laws governing Waste Electrical and Electronic Equipment (WEEE) at a recognised disposal facility.

# ELECTRICAL CONNECTIONS



**WARNING: READ THESE ELECTRICAL SAFETY INSTRUCTIONS THOROUGHLY BEFORE CONNECTING THE PRODUCT TO THE MAINS SUPPLY.**

Before switching the product on, make sure that the voltage of your electricity supply is the same as that indicated on the rating plate. This product is designed to operate on 230VAC 50Hz. Connecting it to any other power source may cause damage.

This product may be fitted with a non-rewireable plug. If it is necessary to change the fuse in the plug, the fuse cover must be refitted. If the fuse cover becomes lost or damaged, the plug must not be used until a suitable replacement is obtained.

If the plug has to be changed because it is not suitable for your socket, or due to damage, it should be cut off and a replacement fitted, following the wiring instructions shown below. The old plug must be disposed of safely, as insertion into a mains socket could cause an electrical hazard.



**WARNING: THE WIRES IN THE POWER CABLE OF THIS PRODUCT ARE COLOURED IN ACCORDANCE WITH THE FOLLOWING CODE:  
BLUE = NEUTRAL    BROWN = LIVE**

If the colours of the wires in the power cable of this product do not correspond with the markings on the terminals of your plug, proceed as follows.

- The wire which is coloured **Blue** must be connected to the terminal which is marked **N** or coloured **black**.
- The wire which is coloured **Brown** must be connected to the terminal which is marked **L**, or coloured red

**Plug must be BS1363/A approved.**

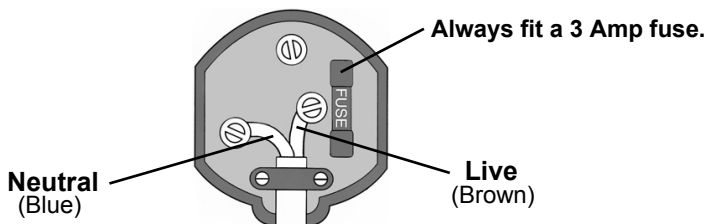

**Ensure that the outer sheath of the cable is firmly held by the clamp**

**We strongly recommend that this machine is connected to the mains supply via a Residual Current Device (RCD)**

If in any doubt, consult a qualified electrician. DO NOT attempt any repairs yourself.



This symbol indicates that this is a Class II product, and does not require an earth connection.

---

# ASSEMBLY AND OPERATION

---

## SETTING UP

The lamp may be tilted and the arm set at any angle by slackening the pinch bolts, adjusting the angle and re-tightening.

Do not over tighten the pinch bolts. When they are correctly tightened, the lamp should be capable of maintaining stability in any position.

## MAINTENANCE

The lamp requires no maintenance other than cleaning the lens. Liquid glass cleaner may be used to clean the lens, used sparingly and with a soft dry cloth. **Do not allow** the LEDs or electrical connections to get wet.

**IMPORTANT:** Always switch the lamp OFF and unplug from the power supply before cleaning the lens.

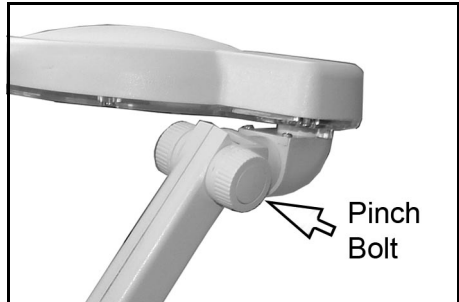

## CARE & STORAGE

1. When not in use, switch off & unplug from the power supply.
2. This product should be stored in a secure, dry place, out of the reach of children. DO NOT leave it exposed to the elements and avoid direct sunlight, direct heat, rain/moisture etc.
3. Keep the external surfaces clean. Avoid impact damage & do not allow this product to come into contact with abrasive or corrosive materials.
4. Do not use solvents, thinners or alcohol for cleaning, as these chemicals will damage the finish. With the lamp unplugged from the power supply, use a dry cloth to wipe over the lamp components.
5. Only use extension leads that are of an appropriate power rating and suitable for the work environment. Inspect the extension lead regularly and replace if damaged.
6. Only use parts and accessories recommended in this manual. Never use unauthorised accessories or attachments which may result in personal injury or damage to the product.

Do not attempt to repair or modify this product or attempt any electrical repair yourself. Consult a qualified electrician or the Clarke Service Department on 020 8988 7400.

## SPECIFICATIONS

<b>Model Number</b>	<b>TML89</b>
Product dimensions (L x W x H)	460 x 137 x 510 mm
Weight	0.9 kg
Operating Temperature	0-35°C
Duty Cycle	S1 (continuous)
Fuse Rating	3A
Power Supply	230V @50Hz 1ph
Insulation Class	II
IP Rating	IP20
Lens type/diameter	Glass/90 mm
Number of LEDs	18
Luminance	5000 lux @15 cm
Lumen output	320 @1 m
Colour temperature	6300K
Efficiency Class	A++, A+, A
Life expectancy	20,000 hours

# COMPONENT PARTS

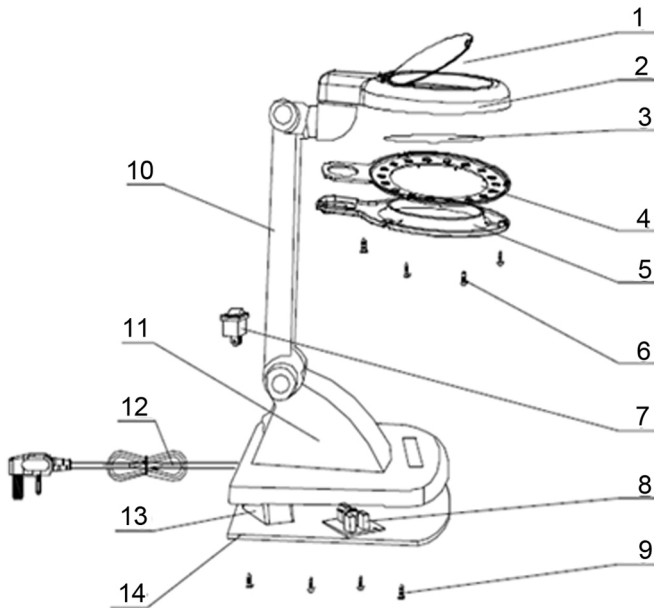

Item No	Description	Qty
1	Lens Cover	1
2	Plastic Head	1
3	Lens (3D)	1
4	LED Board	1
5	Diffuser	1
6	Screws	4
7	On/Off Switch	1
8	LED Driver	1
9	Screws	4
10	Arm & Screw Fastening	1
11	Base Housing	1
12	BS Plug & Cable	1
13	Weight	1
14	Base Bottom Cover	1

# DECLARATION OF CONFORMITY



**Clarke**<sup>®</sup>  
**INTERNATIONAL**

Hemnall Street, Epping, Essex CM16 4LG

## DECLARATION OF CONFORMITY

This is an important document and should be retained.

We hereby declare that this product(s) complies with the following directive(s):

2014/30/EU *Electromagnetic Compatibility Directive.*

2014/35/EU *Low Voltage Equipment Directive.*

2011/65/EU *Restriction of Hazardous substances.*

The following standards have been applied to the product(s):

*EN 60598-2-4: 1997, EN 60598-1-2015+AC: 2016, EN, 55015:2015, EN 61547:2010*

*EN 61000-3-2:2014, EN 61000-3-2:2013.*

The technical documentation required to demonstrate that the product(s) meet(s) the requirement(s) of the aforementioned directive(s) has been compiled and is available for inspection by the relevant enforcement authorities.

The CE mark was first applied in: 2006

**Product Description:** Desk top magnifying LED lamp  
**Model number(s):** TML89  
**Serial / batch Number:** N/A  
**Date of issue:** 22/11/2016

Signed:



J.A. Clarke  
Director

# A SELECTION FROM THE VAST RANGE OF

# Clarke®

## QUALITY PRODUCTS

### AIR COMPRESSORS

From DIY to industrial, Plus air tools, spray guns and accessories.

### GENERATORS

Prime duty or emergency standby for business, home and leisure.

### POWER WASHERS

Hot and cold, electric and engine driven - we have what you need

### WELDERS

Mig, Arc, Tig and Spot. From DIY to auto/industrial.

### METALWORKING

Drills, grinders and saws for DIY and professional use.

### WOODWORKING

Saws, sanders, lathes, mortisers and dust extraction.

### HYDRAULICS

Cranes, body repair kits, transmission jacks for all types of workshop use.

### WATER PUMPS

Submersible, electric and engine driven for DIY, agriculture and industry.

### POWERTOOLS

Angle grinders, cordless drill sets, saws and sanders.

### STARTERS/CHARGERS

All sizes for car and commercial use.

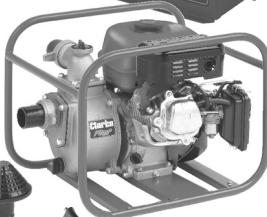

**PARTS & SERVICE: 0208 988 7400**  
E-mail: [Parts@clarkeinternational.com](mailto:Parts@clarkeinternational.com) or [Service@clarkeinternational.com](mailto:Service@clarkeinternational.com)  
**SALES: UK 01992 565333 or Export 00 44 (0)1992 565335**

**Clarke® INTERNATIONAL** Hemnall Street, Epping, Essex CM16 4LG  
[www.clarkeinternational.com](http://www.clarkeinternational.com)