



SHELF UNIT

Model No: CS5150 Part Nos: 6600400 - 150kg Galvanised
 Part Nos: 6600450, 6600470, 6600472 - 150kg Painted
 Model No: CS5350 Part Nos: 6600405 - 350kg Galvanised
 6600455, 6600480, 6600882 - 350kg Painted

ASSEMBLY INSTRUCTIONS

PARTS INVENTORY CHECKLIST

MDF Shelves	5
Short shelf supports	10
Long Shelf Supports	10
Angle Leg Sections	8
Angle leg Joiners	8
Plastic floor protectors	8
Nuts and Bolts	4

Please read these instructions before assembly.

TOOLS NEEDED FOR THE JOB

- A Hammer or a Mallet

SAFETY TIPS

- Please Handle Sharp Metal Edges Carefully

IMPORTANT: IT IS STRONGLY RECOMMENDED THAT YOU WEAR A GOOD PAIR OF INDUSTRIAL GLOVES WHEN ASSEMBLING THIS UNIT, TO AVOID INJURY DUE TO THE POSSIBILITY OF THERE BEING SHARP EDGES AND CORNERS.

Decide on the position you require the bottom shelf to be.

Fit 1 short shelf support between the 2 leg angles.

Repeat this again making sure that the same short shelf support is at the same height.

Now fit the 2 long shelf supports matching the 2 short shelf supports.

Always hammer gently, being sure the shelf support tabs are in line with the leg angle slots.

If the tabs are out of line, simply bend them to line up either way to suit.

Do not use force and damage the tabs.

When hammering the shelf supports, always hammer the leg surface closest to the angle.

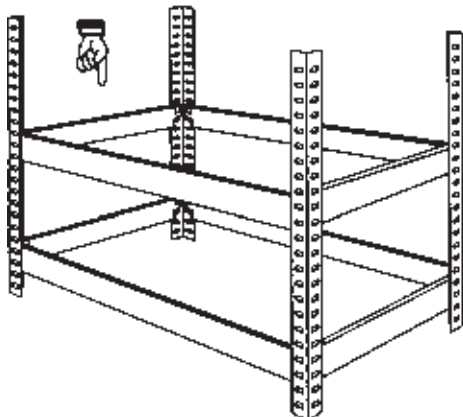
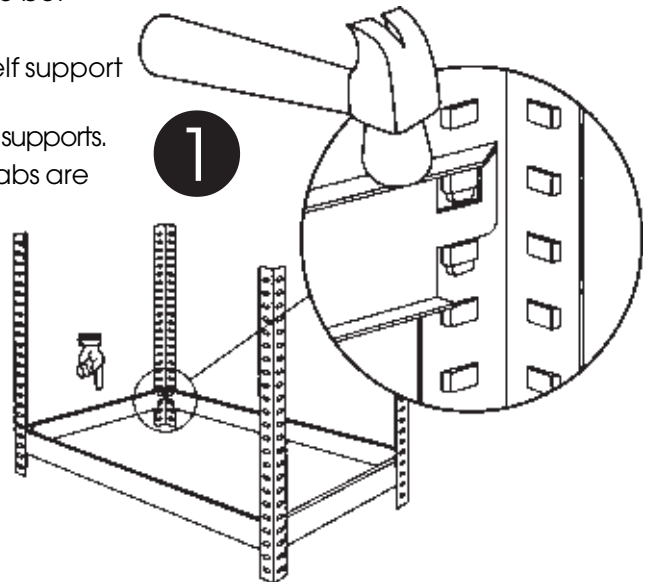

2

Fit another 2 short shelf supports at the desired height then fit the 2 long shelf supports to match the short shelf supports.

3

Secure the MDF shelves on to the shelf supports after full assembly.

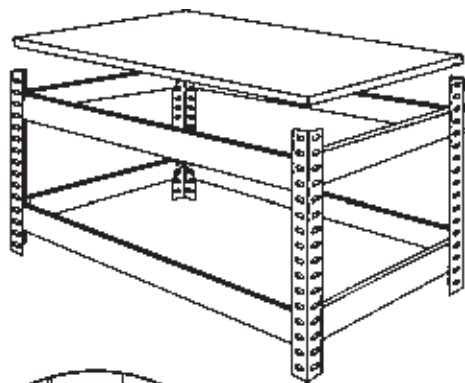

4

To extend the legs, use the leg joiners in the angle of each leg, as illustrated. However, if you require a shelf to be located at the joint, refer to step 5

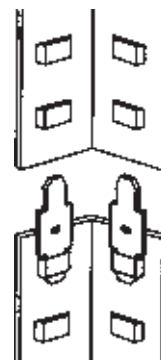

6

Fit the floor protectors provided on the end of each leg.

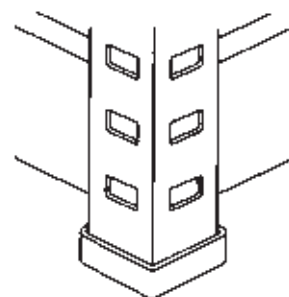

5

For assembly as a 5 shelf unit, with a shelf at the joint between top and bottom leg.....

Fit a short shelf support between the top legs, as shown, then insert the lower tab of the shelf support into the top slot of the lower leg. Repeat this at the other end, then fit the 2 long shelf supports.

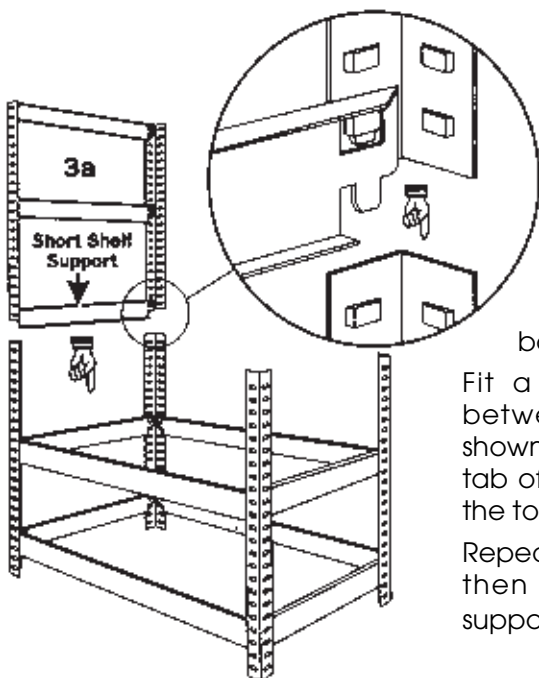

7

Assembling as a standard bench

Refer to Step 1 and Step 2, assemble as shown, bolting the two frames together with the nuts and bolts supplied, then place the 4 MDF shelves as in step 3.

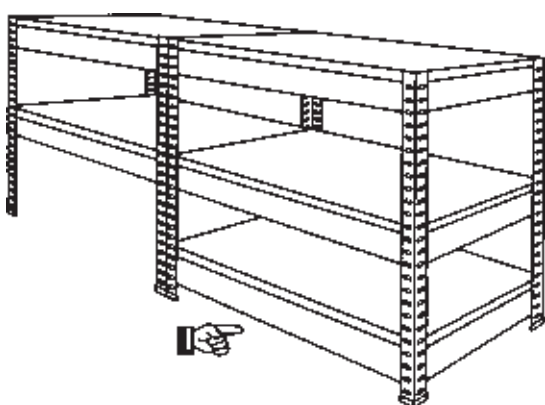

8

Assembling as a corner bench

The same assembly instructions apply as Step 7 except you bolt the bench together at right angles as illustrated.

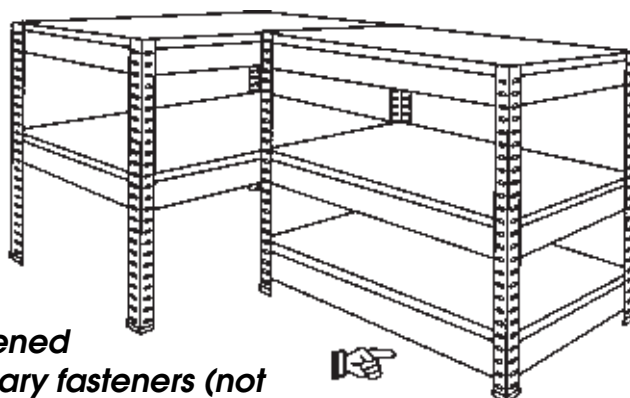

MAY WE SUGGEST...

- **Your Hammer fast Shelving should be fastened to the wall where possible with the necessary fasteners (not included).**
- **Always place heavier items on the lower shelves.**
- **Always evenly distribute your loads across the shelves where possible.**