

# Clarke® **POWER WASHER**



## **POWERWASHER**

Models:

PLS130AB & PLS130AH - PLS200AB & PLS200AH  
DLS200AL & PLS160AH

OPERATING & MAINTENANCE  
INSTRUCTIONS



0108

## CONTENTS

Guarantee .....	3
Specifications .....	3
Safety Precautions .....	4
Features .....	4
Assembly and Preparation for Use .....	5
Operation .....	6
Chemical Cleaning Agents .....	6
Maintenance .....	7
Parts and Service Contacts .....	7
Parts Lists and Diagrams .....	8 - 11

### DECLARATION OF CONFORMITY

We declare that this product complies to the following standards/directives:

- **98/37/EC**
- **2000/14/EC**  
**Annex V1 Procedure 1**

<b>Guaranteed Sound Power Level</b>	PLS130AH 105dBA	PLS160AH 104dBA	PLS200AH 105dBA	PLS200AL 121dBA
---	--------------------	--------------------	--------------------	--------------------

**Product Description:** Power Washer

**Model No:** PLS Range

**Serial (Batch) No:** **See Product Data Plate**

Signed   
Engineering Manager

**Clarke** INTERNATIONAL  
Hemnal Street, Epping, Essex CM16 4LG

October, 2007

Clarke International is a trading style of Clarke International Limited

Thank you for selecting this CLARKE Power Washer for your cleaning requirements. This booklet contains important information about its operation and maintenance and should be read in conjunction with a similar guide produced by the manufacturers of the engine fitted to this particular unit.

Please read both of these carefully before using the machine.

## GUARANTEE

This CLARKE product is guaranteed against faults in manufacture for twelve months from the date of purchase.

In case it is necessary to make a claim under this scheme, please retain your receipt or invoice to show when and where your purchase was made.

This guarantee will not be valid if the product is found to have been abused in anyway, or used otherwise than for its intended purpose.

Under the Terms of this Warranty, any repair or replacement can only be carried out by Clarke International Limited, or one of our authorised dealers.

Where possible any machine requiring attention should be returned to the dealer from whom it was purchased. Where this is not appropriate, please contact Clarke International, Service Department, Tel. 020 8988 7400

This guarantee does not affect your statutory rights.

## SPECIFICATIONS

	PLS130AB	PLS130AH	PLS160AH	PLS200AH	PLS200AB	DLS200AL
<b>Engine Type</b>	B.&Stratton	Honda	Honda	Honda	B.&Stratton	Lombardini
<b>Engine Rating</b>	5HP	5.5HP	6.5HP	11HP	11HP	8.5HP
<b>Engine Speed</b>	3,400RPM	3,400RPM	3,400RPM	3,400RPM	3,400RPM	3,400RPM
<b>Max. Pressure</b>	120Bar	120Bar	150Bar	200Bar	200Bar	200Bar
<b>Max. Water flow</b>	11LPM	11LPM	11LPM	15 LPM	15LPM	15LPM
<b>Max. Water temp.</b>	50°C	50°C	50°C	50°C	50°C	50°C
<b>Pump Oil Type</b>	SAE20W/40	SAE20W/40	SAE20W/40	SAE20W/40	SAE20W/40	SAE20W/40
<b>Tyre Pressure</b>	30PSI	30PSI	30PSI	30PSI	30PSI	30PSI
<b>Part No.</b>	7330250	7330260	7330280	7330300	7330310	7330320

## GENERAL SAFETY PRECAUTIONS

### WARNING:

Water at high pressure can be dangerous and can cause damage to persons or property if the operator is careless. Never allow anyone to operate this equipment unless they are thoroughly reliable, and familiar with the safety precautions.

- X NEVER** direct the spray towards any person or animal.
- X NEVER** direct the spray towards electrical wiring or equipment.
- X NEVER** hold your finger over the high pressure nozzle.
- X NEVER** allow children to use this machine.
- X NEVER** operate the machine with any of the covers removed.
- X NEVER** attempt any repairs to this machine unless you are properly qualified.
- X NEVER** supply any liquid other than water to the water inlet.
- X NEVER** use the chemical injection facility to introduce solvents, e.g. paint thinners, petrol, oil etc.
- ✓** When making a connection directly to the water mains supply you must ensure that it incorporates a device suitable to prevent liquids syphoning back from the power washer into the mains pipework.
- ✓** After the engine has been stopped and the water supply turned off, but before disconnecting any hose or accessory, **ALWAYS** release any residual pressure in the system by operating the trigger.
- ✓** **ALWAYS** keep the machine itself dry and well clear of water spray
- ✓** When not in use, **ALWAYS** disconnect from the water supply, and ensure the system is completely drained. Store in a cool dry location.
- ✓** When using the chemical injection facility, use only the chemical cleaning agents (detergents), that are approved for power washers. CLARKE Traffic Film Remover or CLARKE Wash and WAX (available from your dealer), is recommended.

## FEATURES

These fully portable machines incorporate a variable pressure control, together with a fan or jet spray, and may be used with or without a detergent. Although these machines were designed to operate using a mains water supply, they will also work satisfactorily with a supply which is under positive pressure, i.e. from an elevated water tank etc.

### IMPORTANT:

When using the mains water supply, you must ensure you comply with all local bye laws.

## ASSEMBLY and PREPARATION FOR USE.

- A - Pressure Regulator Knob
- B - Low Pressure Water Inlet
- C - High Pressure Water Outlet
- D - Pressure Gauge
- E - Unloader Valve
- F - Detergent Hose

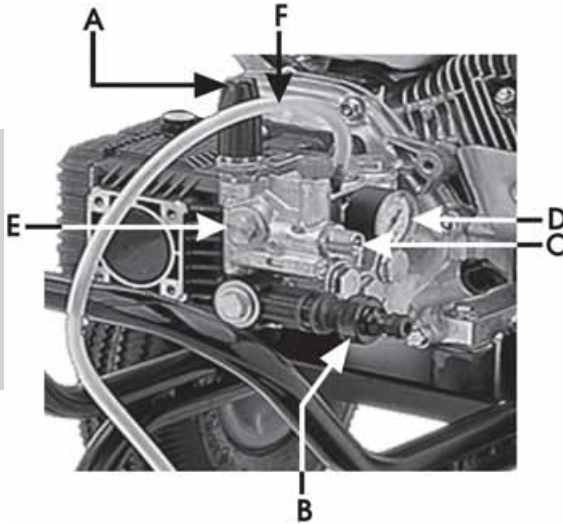

1. Attach the handle to the frame, using the plastic screws supplied.
2. Assemble the lance, by screwing the two halves together securely, with the hand grip in any position convenient to the operator.
3. Two nipple sizes are supplied. That with the larger bore, is the low pressure nipple, and should be screwed in to the tube nearest to the hand grip, using a suitable socket.  
The smaller bore nipple, is therefore screwed into the tube furthest from the hand grip.
4. Connect one end of the high pressure hose to the upper connection on the unloader valve, and the other end to the connection at the lance, ensuring these seals are correctly in place.  
The hose from the mains supply is connected to the lower connection, as shown in fig.1  
A good quality hose of at least 1/2" should be used, and is available from DIY, Hardware and Gardening Supply stores.  
ALL connections must be tight to avoid leaks.
5. Check the pump oil level using the sight glass, but be aware that if the level is not visible, it may be as a result of OVER filling, and should be checked by removing the filler plug, and checking. Top up where necessary with the recommended oil ONLY.
6. Refer to the handbook supplied for the engine, and check the engine oil level, topping up where necessary with the recommended oil ONLY.

## OPERATION

1. Turn the water supply fully ON at the mains.
2. Refer to the engine handbook, and start the engine. Move the speed lever to MAX.
3. To set the lance at high pressure, turn the hand grip of the lance clockwise (i.e. screw it 'IN'), as far as it will go. Low pressure is set by screwing the grip 'OUT'.

**NOTE: Low pressure setting is used for detergent spraying.**

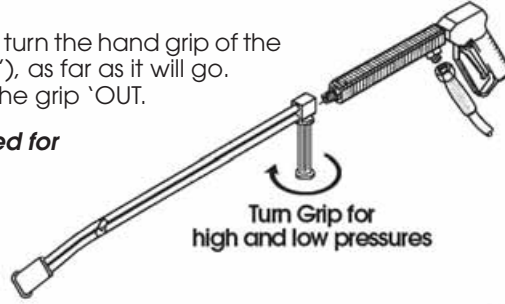

4. Check that there are no leaks in the line connections. Switch off the engine and make the necessary repairs before re-starting the engine, and pressing the trigger of the lance.
5. With the lance set at high pressure, (i.e. the hand grip screwed 'in'), the pressure may be regulated by turning the adjuster knob on the unloader valve.
6. The low pressure setting is used for detergent pick-up (see below). ALWAYS ensure the filter is attached to the end of the pick-up tube, and is completely submerged in the detergent. It is not necessary to adjust the pressure at the unloader valve when set to low pressure.

### NOTE:

1. ***If there is any difficulty in starting the engine, particularly the diesel model, get an assistant to fully depress the lance trigger whilst you attempt to start. This will relieve any pressure in the pump so that there is no load on the engine, making for an easier start.***
2. ***Be aware that the pump delivers a considerable pressure. If the lance is set to high pressure and the trigger is depressed, you will experience a kick back. Ensure you are prepared for this, and hold the lance firmly. DO NOT allow children to hold or operate the lance.***

## CHEMICAL CLEANING AGENTS

To improve cleaning qualities, chemical cleaning agents (detergents) may be injected into the low pressure spray. This is particularly useful for washing cars, greasy engine parts, oil spots on concrete etc.

To inject a detergent, insert the clear plastic hose with filter attachment into the detergent container, ensuring it is completely submerged.

**NOTE: Use ONLY detergents designed for use with power washers. We recommend the use of CLARKE Traffic Film Remover, which is a powerful low foaming agent, for car cleaning, as well as other cleaning tasks.**

When detergent injection is required, screw the lance hand grip 'out' (anticlockwise), to the low pressure setting, and the detergent will automatically

be drawn into the water supply.

Spray the detergent on to the vehicle, patio etc., and allow it to work itself into the grime.

To rinse, set the lance to its' high pressure setting, and blast off the off the dirt.

After cleaning, suspend the detergent hose in a container of clean water. Set the lance to low pressure, and with the engine running, and the mains water supply 'on', depress the trigger of the lance, and thoroughly flush out the system.

## MAINTENANCE

If detergents have been used, it is important to flush the system with clean water for a few minutes after use.

If there is a danger of freezing, anti freeze should be mixed with the flush water, or the system must be completely drained.

After the final flush, stop the engine; do not allow it to idle for longer than 15 seconds.

### Storage

Store in an upright position, completely drained of water, in a dry location.

### Engine

Refer to the engine handbook, and service accordingly.

**NOTE: Engine oil should be checked regularly.**

### Pump

Change the oil after the first 50 hours of service, and every 500 hours thereafter.

Check the level as described on page 3

DO NOT attempt to carry out any mechanical repairs yourself. Please contact your CLARKE dealer for Service and repairs

## PARTS & SERVICE CONTACTS

For Spare Parts and Service, please contact your nearest dealer,  
or CLARKE International, on one of the following numbers.

**PARTS & SERVICE TEL: 020 8988 7400**

**PARTS & SERVICE FAX: 020 8558 3622**

or e-mail as follows:

**PARTS: [Parts@clarkeinternational.com](mailto:Parts@clarkeinternational.com)**

**SERVICE: [Service@clarkeinternational.com](mailto:Service@clarkeinternational.com)**

## PARTS LIST

### PLS200AB, PLS200AH & DLS200AL

No.	Description	Qty	Part No.	No.	Description	Qty	Part No.
1	Engine (200AB) 11HP	1	8000118	16	Screw M8x12	4	3044506
1	Engine (200AH) 11HP	1	8000081	17	Washer M8	4	3044582
1	Engine (200AL) 11HP	1	8000805	18	Washer M8	4	3044582
2	Pump	1	AR20001	19	Screw M8	4	3044506
3	Frame	1	8050490	20	Engine Bracket	2	8050700
4	Screw	4	3040526	21	Anti Vibration Mount	4	8950357
5	Washer	4	3040583	22	Nut M8	2	3040611
6	Key	1	3040481	23	Washer M8	2	3044576
7	Screw (200AB)	4	3044508	24	Saddle	2	2100308
	Screw (200AH)	4	3044509	25	Feet	2	2100313
	Screw (200AL)	4	3044518	26	Screw	2	3044508
8	Washer M8 (200AB)	4	3044576	27	Plastic Insert	2	2000337
	Washer M10 (200AH)	4	3044577	28	Screw	2	3044544
	Washer M10 (200AL)	4	3044577	29	Washer	2	1301402
9	Washer M8 (200AB)	4	3044576	30	Knob M6x40	2	7200326
	Washer M10 (200AH)	4	3044577	31	Label (Spec.)	1	8950880
	Washer M10 (200AL)	4	3044577	32	Label (POWERWASH)	1	8950885
10	Nut M8 (200AB)	4	3040611	33	Hose	1	AR13004
	Nut M10 (200AH)	4	3040612	34	Lance Handle Assy	1	AW010431806
	Nut M10 (200AL)	4	3040612	35	Twin Lance	1	AW004392403
11	Pressure Gauge	1	AR13003	36	Nozzle HP	1	AW004180210
12	Unloader	1	AR13007	37	Nozzle LP	1	AW004180221
13	Hose Connection	1	AR15504	38	Wheel 260x20	2	2100280
14	Chemical Hose	1	AR15502	39	Washer	2	3044583
15	Chemical Filter	1	AR15503	40	Split Pin	2	2200302



# PARTS DIAGRAM

## PLS200AB, PLS200AH, DLS200AL

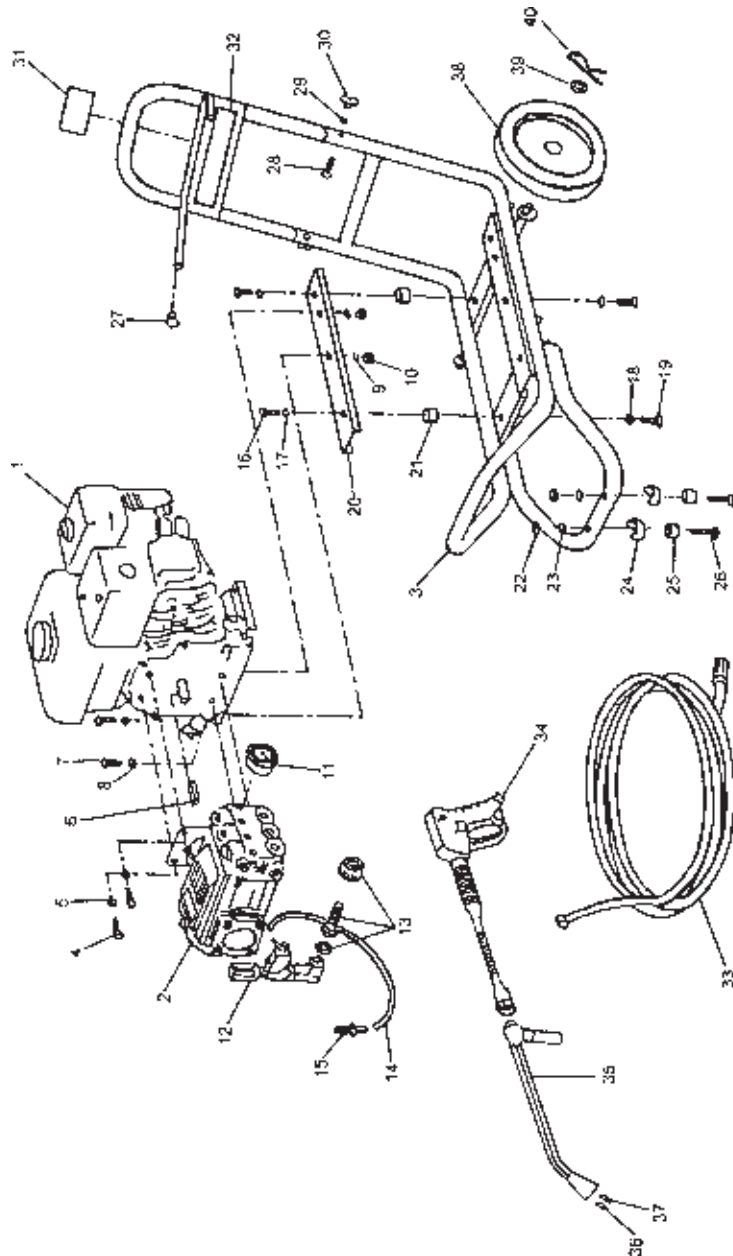

## PARTS LIST

### PLS130AB & PLS130AH

No.	Description	Qty	Part No.	No.	Description	Qty	Part No.
1	Engine (130AB)	1	8000113	16	Anti Vibration Mount	4	8950357
1	Engine (130AH)	1		17	Plastic Foot	2	2100302
2	Pump	1	AR13001	18	Knob M6x40	2	7200362
3	Frame	1	8050480	19	Washer	2	1301402
4	Screw	4	3040490	20	Screw	2	3040543
5	Washer	4	3044576	21	Plastic Insert	2	2000337
6	Key	1	3040483	22	Wheel	2	2100280
7	Screw (130AB)	4	3044504	23	Washer	2	3044573
	Screw (130AH)	4	3044503	24	Split Pin	2	2200302
8	Washer	4	3044582	25	Label (Spec.)	1	8950880
9	Washer	4	3044582	26	Label (POWERWASH)	1	8950885
10	Nut	4	3044506	27	Hose	1	AR13004
11	Pressure Gauge	1	AR13009	28	Lance Handle Assy	1	AW010431806
12	Unloader	1	AR13005	29	Twin Lance	1	AW004392403
13	Hose Connection	1	AR15504	30	Nozzle HP	1	AW004280209
14	Chemical Hose	1	AR15502	31	Nozzle LP	1	AW004180221
15	Chemical Filter	1	AR15503				

### PLS160AH

No.	Description	Qty	Part No.	No.	Description	Qty	Part No.
1	Engine (160AH)	1	8000055	17	Plastic Foot	2	2100302
2	Pump	1	AR16001	18	Knob M6x40	2	7200362
3	Frame	1	8050480	19	Washer	2	1301402
4	Screw	4	3040490	20	Screw	2	3040543
5	Washer	4	3044576	21	Plastic Insert	2	2000337
6	Key	1	3040483	22	Wheel	2	2100280
7	Screw	4	3044503	23	Washer	2	3044583
8	Washer	4	3044582	24	Split Pin	2	2200302
9	Washer	4	3044582	25	Label (Spec.)	1	8950880
10	Nut	4	3044506	26	Label (POWERWASH)	1	8950885
11	Pressure Gauge	1	AR13009	27	Hose	1	AR13004
12	Unloader	1	AR13006	28	Lance Handle Assy	1	AW010431806
13	Hose Connection	1	AR15504	29	Twin Lance	1	AW004392403
14	Chemical Hose	1	AR15502	30	Nozzle HP	1	AW004180208
15	Chemical Filter	1	AR15509	31	Nozzle LP	1	AW004180221
16	Anti Vibration Mount	4	8950357				

# PARTS DIAGRAM

## PLS130AB, PLS130AH, PLS160AH

