

Clarke®

weld



NO GAS MIG WELDER

MIG85ENB

Part No. 6010109

0606

OPERATING & MAINTENANCE INSTRUCTIONS



Thank you for purchasing this CLARKE NO-GAS MIG Welder.

Before attempting to operate the machine, it is essential that you read this manual thoroughly and carefully follow all instructions given. In doing so you will ensure the safety of yourself and that of others around you, and you can also look forward to the welder giving you long and satisfactory service.

CLARKE GUARANTEE

This CLARKE product is guaranteed against faulty manufacture for a period of 12 months from the date of purchase. Please keep your receipt as proof of purchase.

This guarantee is invalid if the product is found to have been abused or tampered with in any way, or not used for the purpose for which it was intended.

Faulty goods should be returned to their place of purchase, no product can be returned to us without prior permission.

This guarantee does not effect your statutory rights.

For **Clarke** Service, please contact the following:

TEL: 020 8988 7400

or e-mail

Service@clarkeinternational.com

CONTENTS

PAGE

Guarantee	2
Electromagnetic Interference (EMC)	4
Safety Precautions	6
Additional Safety Precautions for MIG Welding	11
Principles of Operation	13
Electrical Connections	14
Unpacking and Parts Identification	15
Assembly	16
Installing Welding Wire	16
Welding Shield	18
Preparation for Use	
Preparing the Work	19
Setting the Controls	19
Attaching the Earth Clamp	20
Control Settings Reference Tables	20
MIG Welding Operation	21
Thermal Overload	21
Welding Tips	22
Maintenance	22
Troubleshooting	23
Parts Lists	24
Parts Diagram	25
Wiring Diagrams	26
Parts & Service Contacts	26
Welder Specifications	27
Accessories	27

ELECTROMAGNETIC INTERFERENCE (EMC)

Whilst this unit complies with EMC regulations, the user is responsible for installing and using the welding equipment according to the manufacturers instructions. If electromagnetic disturbances are detected then it shall be the responsibility of the user of the welding equipment to resolve the situation. In some cases this remedial action may be as simple as earthing the welding circuit, see 'Note'. In other cases it could involve constructing an electromagnetic screen enclosing the power source and the work complete with associated input filters. In all cases electromagnetic disturbances must be reduced to the point where they are no longer troublesome.

Note - The welding circuit may or may not be earthed for safety reasons. Changing the earthing arrangements should only be authorised by a person who is competent to assess whether the changes will increase the risk of injury, e.g. by allowing parallel welding current return paths which may damage the earth circuits of other equipment.

1. ASSESSMENT OF AREA

Before installing welding equipment the user shall make an assessment of potential electromagnetic problems in the surrounding area. Avoid using your welder in the vicinity of:

- a) other supply cables, control cables, signalling and telephone cables; above, below and adjacent to the welding equipment;
- b) radio and television transmitters and receivers;
- c) computer and other control equipment;
- d) safety critical equipment, e.g. guarding of industrial equipment;
- e) pacemakers and hearing aids etc.;
- f) equipment used for calibration or measurement;
- g) other equipment in the environment. The user shall ensure that other equipment being used in the environment is compatible. This may require additional protection measures;



It may be possible to avoid the above by changing the time of day that welding or other activities are to be carried out.

The size of the surrounding area to be considered will depend on the structure of the building and other activities that are taking place. The surrounding area may extend beyond the boundaries of the premises.

2. METHODS OF REDUCING EMISSIONS

2.1 Mains supply

Welding equipment should be connected to the mains supply according to the manufacturers recommendations. If interference occurs, it may be necessary to



take additional precautions such as filtering of the mains supply. Consideration should be given to shielding the supply cable of permanently installed welding equipment, in metallic conduit or equivalent. Shielding should be electrically continuous throughout its length. The shielding should be connected to the welding power source so that good electrical contact is maintained between the conduit and the welding power source enclosure.

2.2 Maintenance of the welding equipment

The welding equipment should be routinely maintained according to the manufacturers recommendations. All access and service doors and covers should be closed and properly fastened when the welding equipment is in operation. The welding equipment should not be modified in any way except for those changes and adjustments covered in the manufacturers instructions. In particular, the spark gaps of arc striking and stabilizing devices should be adjusted and maintained according to the manufacturers recommendations.

2.3 Welding cables

The welding cables should be kept as short as possible and should be positioned close together, running at or close to the floor level.

2.4 Equipotential bonding

Bonding of all metallic components in the welding installation and adjacent to it should be considered. However, metallic components bonded to the work piece will increase the risk that the operator could receive a shock by touching these metallic components and the electrodes at the same time. The operator should be insulated from all such bonded metallic components.

2.5 Earthing of the workpiece

Where the workpiece is not bonded to earth for electrical safety, nor connected to earth because of its size and position, e.g. ships hull or building steelwork, a connection bonding the workpiece to earth may reduce emissions in some, but not all instances.

Care should be taken to prevent the earthing of the workpiece increasing the risk of injury to users, or damage to other electrical equipment.

Where necessary, the connection of the workpiece to earth should be made by a direct connection to the workpiece, but in some countries where direct connection is not permitted, the bonding should be achieved by suitable capacitance, selected according to national regulations.

2.6 Screening and shielding

Selective screening and shielding of other cables and equipment in the surrounding area may alleviate problems of interference. Screening of the entire welding installation may be considered for special applications.

SAFETY PRECAUTIONS FOR ALL TYPES OF WELDING

1. WARNING:

As with all machinery, there are certain hazards involved with their operation and use. Exercising respect and caution will considerably lessen the risk of personal injury. However, if normal safety precautions are overlooked, or ignored, personal injury to the operator may result.

FAILURE TO FOLLOW THESE RULES MAY RESULT IN SERIOUS PERSONAL INJURY

2. GENERAL PRECAUTIONS

A) Burn prevention

Wear protective clothing - gauntlet gloves designed for use in welding, apron, and protective shoes. Button shirt collar and pocket flaps, and wear cuffless trousers to avoid entry of sparks and slag. Wear helmet with safety goggles or glasses with side shields underneath, appropriate filter lenses or plates (protected by clear cover glass). This is a MUST for welding or cutting, (and chipping) to protect the eyes from radiant energy and spatter. Replace cover glass when broken, pitted, or spattered. Avoid oily greasy clothing. A spark may ignite them. Hot metal such as electrode stubs and workpieces should never be handled without gloves. First aid facilities and a qualified first aid person should be available unless medical facilities are close by for immediate treatment of flash burns of the eyes and skin burns. Ear plugs should be worn when working overhead or in a confined space. A hard hat should be worn when others work overhead. Flammable hair preparations should not be used by persons intending to weld or cut.

B) Toxic fume prevention

Severe discomfort, illness or death can result from fumes, vapours, heat, or oxygen enrichment or depletion that welding (or cutting) may produce. Prevent them with adequate ventilation. NEVER ventilate with oxygen. Lead-, cadmium-, zinc-, mercury- and beryllium-, bearing materials, when welded (or cut) may produce harmful concentrations of toxic fumes. Adequate local exhaust ventilation must be used, or each person in the area as well as the operator must wear an air-supplied respirator. For beryllium, both must be used. Metals coated with or containing materials that emit toxic fumes should not be heated unless coating is removed from the work surface, the area is well ventilated, or the operator wears an air-supplied respirator. Work in a confined space only while it is being ventilated and, if necessary, while wearing an air-supplied respirator. Vapours from chlorinated solvents can be decomposed by the heat of the arc (or flame) to form PHOSGENE, a highly toxic gas, and other lung and eye irritating products. The ultraviolet (radiant) energy of the arc can also decompose trichloroethylene and perchloroethylene vapours to form phosgene. DO NOT WELD or cut where solvent vapours can be drawn into the welding or cutting atmosphere or where the radiant energy can penetrate to atmospheres containing even minute amounts of trichloroethylene or perchloroethylene.

C) Fire and explosion prevention

Causes of fire and explosion are:

- 1) combustibles reached by the arc, flame, flying sparks, hot slag or heated material;
- 2) misuse of compressed gases and cylinders;
- 3) short circuits.

BE AWARE THAT flying sparks or falling slag can pass through cracks, along pipes, through windows or doors, and through wall or floor openings, out of sight of the goggled operator. Sparks and slag can fly 10M.

To prevent fires and explosion: keep equipment clean and operable, free of oil, grease, and (in electrical parts) of metallic particles that can cause short circuits. If combustibles are in area, do NOT weld or cut. Move the work if practicable, to an area free of combustibles.

Avoid paint spray rooms, dip tanks, storage areas, ventilators. If the work cannot be moved, move combustibles at least 10M, away out of reach of sparks and heat; or protect against ignition with suitable and snug fitting, fire-resistant covers or shields.

Walls, ceilings, and floor near work should be protected by heat resistant covers or shields. Fire watcher must be standing by with suitable fire extinguishing equipment during and for some time after welding or cutting if:

- a) appreciable combustibles (including building construction) are within 10m.
- b) appreciable combustibles are further than 10m but can be ignited by sparks.
- c) openings (concealed or visible) in floors or walls within 10m can expose combustibles to sparks.
- d) combustibles adjacent to walls, ceilings, roofs or metal partitions can be ignited by radiant or conducted heat.

After work is done, check that area is free of sparks, glowing embers, and flames. An empty container that held combustibles, or that can produce flammable or toxic vapours when heated, must never be welded on or cut, unless container has first been cleaned. This includes.....a thorough steam or caustic cleaning (or a solvent or water washing, depending on the combustible's solubility) followed by purging and inerting with nitrogen or carbon dioxide, and using protective equipment.

Water filling just below working level may substitute for inerting.

A container with unknown contents should be cleaned (see paragraph above), do NOT depend on sense of smell or sight to determine if it is safe to weld or cut.

Hollow castings or containers must be vented before welding or cutting - they can explode.

In explosive atmospheres, never weld or cut where the air may contain flammable dust, gas, or liquid vapours.

3. ELECTRIC ARC (MIG, TIG) WELDING

Comply with precautions in 1 above, and this section. Arc welding, properly done, is a safe process, but a careless operator invites trouble. The equipment carries high currents at significant voltages. The arc is very bright and hot. Sparks fly, fumes rise, ultraviolet and infrared energy radiates, weldments are hot. The wise operator avoids unnecessary risks and protects himself and others from accidents.

3A) BURN PROTECTION

Comply with precautions in 2. The welding arc is intense and visibly bright. Its radiation can damage eyes, penetrate lightweight clothing, reflect from light coloured surfaces, and burn the skin and eyes. Skin burns resemble acute sunburn, those from gas - shielded arcs are more severe and painful.

DON'T GET BURNED! COMPLY WITH PRECAUTIONS!

1) Protective clothing

Wear long sleeved clothing (particularly for gas shielded arc) in addition to gloves, apron and shoes (2A). As necessary, use additional protective clothing such as leather jacket or sleeves, flameproof apron, and fire-resistant leggings. Avoid outer garments of untreated cotton. **Bare skin protection:** Wear dark substantial clothing, Button collar to protect chest and neck and button pockets to prevent entry of sparks.

2) Eye and head protection

Protect eyes from exposure to arc. NEVER look at an electric arc without protection. Welding helmet or shield containing a filter plate shade no. 12 or denser must be used when welding. Place over face before striking arc. Protect filter plate with a clear cover plate. Cracked or broken helmet or shield should NOT be worn; radiation can pass through to cause burns. Cracked, broken, or loose filter plates must be replaced IMMEDIATELY. Replace clear cover plate when broken, pitted, or spattered. WE SUGGEST you wear flash goggles with side shields under the helmet, to give some protection to the eyes should the helmet not be lowered over the face before an arc is struck. Looking at an arc momentarily with unprotected eyes (particularly a high intensity gas-shielded arc) can cause a retinal burn that may leave a permanent dark area in the field of vision. Before welding whilst wearing contact lenses, seek advice from your optician.

3) Protection of nearby personnel

For production welding, a separate room or enclosed bay is best. In open areas, surround the operation with low reflective, non- combustible screens or panels. Allow for free air circulation, particularly at floor level. Provide face shields for all persons who will be looking directly at the weld. Others working in the area should wear flash goggles. Before starting to weld, make sure that screen or bay doors are closed.

3B) TOXIC FUME PREVENTION

Comply with precautions in 2B. Generator engine exhaust must be vented to the outside air. Carbon monoxide can kill.

3C) FIRE AND EXPLOSION PREVENTION

Comply with precautions in 2C. Equipment's rated capacity. Do not overload arc welding equipment. It may overheat cables and cause a fire. Loose cable connections may overheat or flash and cause a fire. Never strike an arc on a cylinder or other pressure vessel. It creates a brittle area that can cause a violent rupture or lead to such a rupture later under rough handling.

3D) SHOCK PREVENTION

Exposed live conductors or other bare metal in the welding circuit, or in unearthed, electrically-LIVE equipment can fatally shock a person whose body becomes a conductor. DO NOT STAND, SIT, LIE, LEAN ON, OR TOUCH a wet surface when welding, without suitable protection.

3E) PROTECTION FOR WEARERS OF ELECTRONIC LIFE SUPPORT DEVICES (PACEMAKERS)

Magnetic fields from high currents can affect pacemaker operation. Persons wearing electronic life support equipment (pacemaker) should consult with their doctor before going near arc welding, gouging, or spot welding operations.

3F) TO PROTECT AGAINST SHOCK:

Keep body and clothing dry. Never work in damp area without adequate insulation against electrical shock. Stay on a dry duckboard, or rubber mat when dampness or sweat can not be avoided. Sweat, sea water, or moisture between body and an electrically LIVE part - or earthed metal - reduces the body surface electrical resistance, enabling dangerous and possibly lethal currents to flow through the body.

1) Earthing the equipment

When arc welding equipment is earthed according to the National Electrical Code, and the workpiece is earthed, a voltage may exist between the electrode and any conducting object.

Examples of conducting objects include, but are not limited to, buildings, electrical tools, work benches, welding power source cases, workpieces, etc. Never touch the electrode and any metal object unless the welding power source is off. When installing, connect the frames of each unit such as welding power source, control, work table, and water circulator to the building earth.

Conductors must be adequate to carry earth currents safely. Equipment made electrically LIVE by stray current may shock, possibly fatally. Do NOT EARTH to electrical conduit, or to a pipe carrying ANY gas or a flammable liquid such as oil or fuel.

2) Electrode holders

Fully insulated electrode holders should be used. Do NOT use holders with protruding screws or with any form of damage.

3) Connectors

Fully insulated lock-type connectors should be used to join welding cable.

4) Cables

Frequently inspect cables for wear, cracks and damage. IMMEDIATELY REPLACE those with excessively worn or damaged insulation to avoid possibly lethal shock from bared cable. Cables with damaged areas may be taped to give resistance equivalent to original cable. Keep cable dry, free of oil and grease, and protected from hot metal and sparks.

5) Terminals and other exposed parts

Terminals and other exposed parts of electrical units should have insulating covers secured before operation.

6) Electrode

a) Equipment with output on/off control (contactor)

Welding power sources for use with the gas metal arc welding, gas tungsten arc welding and similar processes normally are equipped with devices that permit on/off control of the welding power output. When so equipped the electrode wire becomes electrically LIVE when the power source switch is ON and welding gun switch is closed. Never touch the electrode wire or any conducting object in contact with the electrode circuit unless the welding power source is off.

b) Equipment without output on/off control (no contactor)

Welding power sources used with shielded metal arc welding and similar processes may not be equipped with welding power output on/off control devices. With such equipment the electrode is electrically LIVE when the power switch is turned ON. Never touch the electrode unless the welding power source is off.

7) Safety devices

Safety devices such as interlocks and circuit breakers should not be disconnected or shunted out. Before installation, inspection, or service of equipment, shut OFF all power and remove line fuses (or lock or red-tag switches) to prevent accidental turning ON of power. Do not open power circuit or change polarity while welding. If, in an emergency, it must be disconnected, guard against shock burns, or flash from switch arcing. Always shut OFF and disconnect all power to equipment. Power disconnect switch must be available near the welding power source.

PREPARATION OF THE WORKING AREA

The working area must be sufficiently spacious, not humid, and well-ventilated as to avoid any fumes which develop from the welding process and from incidental material adhering to the pieces to be welded (oils, paints, tars...) which may cause annoyance to the operator.

Avoid welding by contact with humid parts nearby combustible liquids. Least of all, do not weld upon tanks which may contain flammable residuals.

ADDITIONAL SAFETY PRECAUTIONS for MIG WELDING

- ✓ **ALWAYS** ensure that there is full free air circulating around the outer casing of the machine, and that the louvres are unobstructed.
- ✓ Welding arc can seriously damage your eyes. Both operator and spectators must **ALWAYS** use a proper welding face shield or helmet, with suitable filter lenses. Proper gloves and working clothes should be worn at all times.
- ✓ **ALWAYS** inspect the hose before use to ensure it is in good condition.
- ✓ **ALWAYS** keep the free length of hose outside the work area.
- ✓ **ALWAYS** remove all flammable materials from the welding area.
- ✓ **ALWAYS** Keep fire extinguisher handy....'Dry Powder, CO₂ or BCF, **NOT Water**

- ✗ **NEVER** remove any of the panels unless the machine is disconnected from the supply, AND never use the machine with any of the panels removed.
- ✗ **NEVER** attempt any electrical or mechanical repair unless your are a qualified technician. If you have a problem with the machine contact your local CLARKE dealer.

- X NEVER** use or store in a wet/damp environment. DO NOT EXPOSE TO RAIN.
- X NEVER** continue to weld, if, **at any time**, you feel even the smallest electric shock. Stop welding IMMEDIATELY, and DO NOT attempt to use the machine until the fault is diagnosed and corrected.
- X NEVER** point the MIG torch at any person or animal.
- X NEVER** touch the MIG torch nozzle until the welder is switched OFF and the nozzle has been allowed to cool off.
- X NEVER** connect, disconnect, or attempt to service the MIG torch, until the machine is switched OFF and disconnected from the mains supply.
- X NEVER** allow the cables to become wrapped around the operator or any person in the vicinity.

DANGER - ELECTRIC SHOCK CAN BE FATAL.

A person qualified in first aid should always be present in the working area. If person is unconscious and electric shock is suspected, do not touch the person if he or she is in contact with the welder or cables. Disconnect the welder from the power source and then use First Aid. Dry wood, or other insulating material can be used to move cables, if necessary, away from the person.

SAFETY EQUIPMENT

A comprehensive range of CLARKE safety equipment for use when welding is available from your local dealer.

NO-GAS WELDING - PRINCIPLES OF OPERATION

MIG (Metal Inert Gas) welding is a process in which a power wire electrode is fed continuously into the weld pool at a controlled, constant rate.

The wire is connected to the **negative** side of a rectified voltage supply. The workpiece is connected to the **positive** side of the supply.

When the wire is fed, it comes into contact with the workpiece and an arc is struck. The arc melts the wire and the material, fusing it together.

The wire, which is fed by the wire feed motor is fed into the weld pool, burning itself off at a rate dependent upon the selected wire feed speed.

To protect the weld pool from oxidation and impurities during the welding process, a shielding gas flows over and around the weld pool. This gas flow is provided by a flux core within the welding wire electrode. The flux melts due to the heat produced, giving off a gas. This gas prevents oxygen, in the surrounding air, from coming into contact with the molten pool at a critical time. Solidification takes place, creating a much stronger, cleaner weld, free of impurities.

BENEFITS OF NO-GAS MIG WELDING

1. No need for cumbersome or short life gas bottles
2. Better outdoor use as wind has less chance of disturbing the gas shroud.
3. 50% faster welding time.
4. Operator training time kept to a minimum.
5. There is no slag removal, thus eliminating almost all post-welding cleaning operations.
6. Minimum waste of welding consumables.
7. Overall, a faster more efficient way of getting the job done.
8. Less heat - less distortion.
9. Ability to weld thin material.

ELECTRICAL CONNECTIONS

 **WARNING! THIS APPLIANCE MUST BE EARTHED.**

The welder is fitted with a standard 13 amp BS 1363 plug, fitted with a 13 amp fuse. Connect to a 230 volt (50Hz) domestic electrical supply and **we strongly recommend that this be done via a Residual Current Device (RCD).**

IMPORTANT: The wires in the mains lead are coloured in accordance with the following code:

Green & Yellow Earth
Blue Neutral
Brown Live

As the colours of the flexible cord of this appliance may not correspond with the coloured markings identifying terminals in your plug, proceed as follows:

- Connect GREEN & YELLOW cord to plug terminal marked with a letter "E" or Earth symbol "", or coloured GREEN or GREEN & YELLOW.
- Connect BROWN cord to plug terminal marked letter "L" or coloured RED.
- Connect BLUE cord to plug terminal marked letter "N" or coloured BLACK.

IMPORTANT: If the welder is fitted with a plug which is moulded onto the electric cable (i.e. non- re-wirable) please note:

1. The plug must be thrown away if it is cut from the electric cable. There is a danger of electric shock if it is subsequently inserted into a socket outlet.
2. Never use the plug without the fuse cover fitted.
3. Should you wish to replace a detachable fuse carrier, ensure that the correct replacement is used (as indicated by marking or colour code). Replacement fuse covers can be obtained from your local dealer or most electrical stockists.

Fuse Rating

The fuse in the plug must be replaced with one of the same rating (**13 amps**) and this replacement must be ASTA approved to BS1362.

Extension Cable

If an extension cable is fitted, ensure the minimum cross section of the conductor is 1.5mm² for up to 15 metres in length, and 2.5mm² for up to 25 metres.

UNPACKING & PARTS IDENTIFICATION

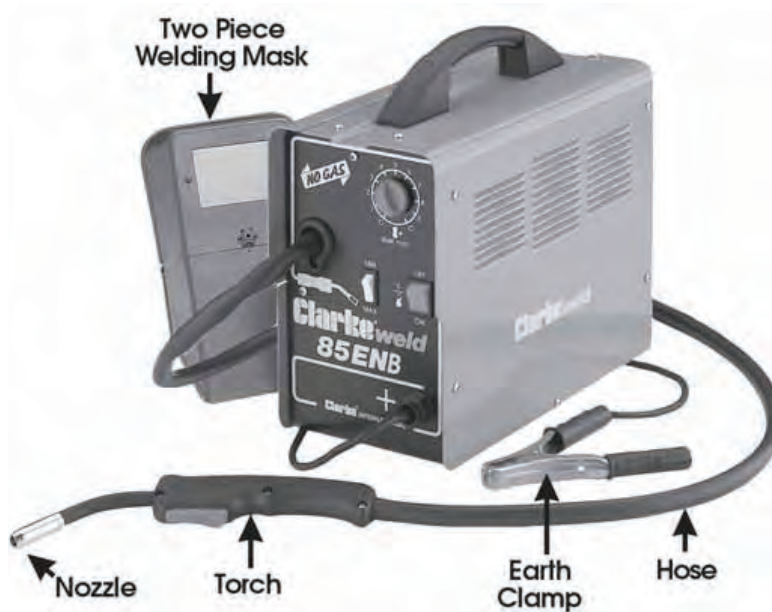

Unpack and lay out the components, checking against the following list. Any damage or deficiency should be reported to your CLARKE dealer immediately.

Some of the components are stored within the side compartment. To open the compartment, pull the side panel up, as indicated in Fig.1.

The cover may be quite tight when new, so ease off gently.

1. Welder complete with Torch and Hose, Earth Cable with Clamp and Power cable.
2. 2-Piece Welding Mask
3. Welding Mask handle, complete with plastic nut and 2xPlastic screws.
4. Package containing 1xClear Glass and Dark Glass Lens
5. Wire Spool, fitted to the Spool Holder
6. Spare welding tip



ASSEMBLY & INSTALLATION

A. INSTALLING THE WELDING WIRE

NOTE: This machine is supplied with a Clarke 'Mini' spool of 0.9mm, mild steel, flux cored welding wire. Replaceable spools available from your Clarke dealer. See 'Accessories' for full details.

1. **IMPORTANT:** Ensure that the electrical supply is disconnected.
2. Firstly remove the side cover, on the left hand side of the unit, by pulling it sharply upwards.

(1) Removing/Replacing the Wire Spool

Fig.3

Re: Fig. 3

If the wire spool is mounted on the spool holder, it needs to be removed in order to remove the plastic wrapper. To do this, proceed as follows:

Pull out the centre retainer, arrowed in Fig.3, then squeeze the retaining lugs together (on the spindle), so that the spool may be withdrawn.

Remove the wrapper and replace the spool, pushing home fully, and ensuring the centre retainer is properly located.



(2) Installing the Wire

Fig.4

Re: Fig.4

1. Loosen the plastic knob (A) by turning it anticlockwise, (this device maintains pressure on the wire).
2. Pull, on the plastic knob, so that the screw rod hinges out of its slot. This releases the pivoted pressure roller bracket (C). Raise the bracket, in the direction of the arrow, and pull out any wire that has been left in the wire liner (D), pulling it from the nozzle end of the hose.

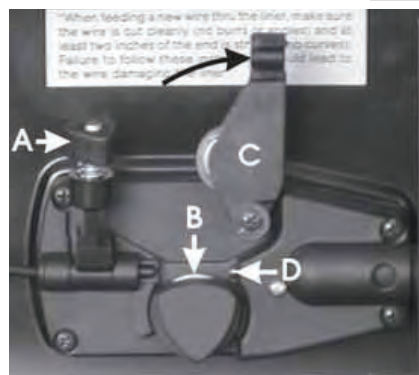

3. **Re: Fig.5**

Pull out the end of the wire from the rim of the spool, taking care NOT to release it. The spool is wound firmly and should remain this way.

Ensuring the wire is straight and not kinked in any way, clip off the end cleanly, ensuring there are no burrs or sharp edges.

Proceed to feed it through the guide tube (E), over the groove on the roller (B), and into the wire liner (D), by about 10 - 15 cm.

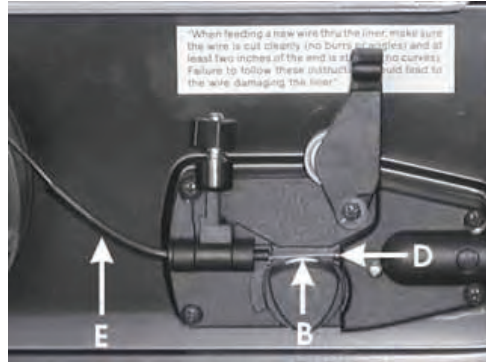

Fig.5

4. Reposition the pressure roller bracket (C, FIG.4) and plastic knob (A, Fig.4) and tighten slightly.

CAUTION:

Tightening the knob (A) too tightly will crush the wire and damage the wire feed motor, too loose will not allow the wire to be pulled by the roller.

5. **(Ref. Fig 6)**

Unscrew and remove the torch shroud by twisting it anti clockwise, then unscrew the contact tip.

6. Close the side panel of the machine, plug into a 230V, 50HZ outlet (or switch on Isolator).

Set the 'WIRE FEED' rotary switch, on the front panel, to position 7OR 8, switch on the machine and press the trigger.

The wire will feed through the hose and when it appears at the torch end, release the trigger, switch off the machine and disconnect the machine from the mains supply. Replace the contact tip and the torch shroud.

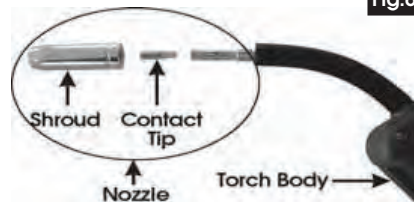

Fig.6

IMPORTANT:

Ensure the hose is kept straight during this operation, to assist the wire as it is fed through to the wire liner and contact tip.

B. ASSEMBLING THE WELDING SHIELD

To assemble the welding shield, (Fig.2), insert the clear glass panel first, followed by the dark glass panel into the recess in the shield, i.e. the clear glass MUST be on the outside of the shield. Securing them with the plastic screws provided.

Slot the two pieces together as shown, and enter the threaded end of the handle into the holes provided. Thread on the plastic nut and tighten.

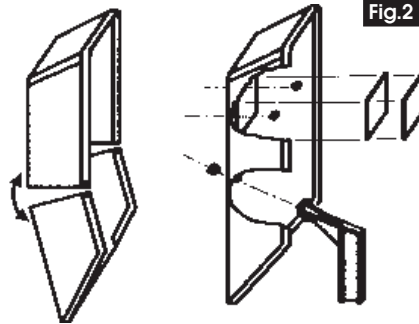

It is important to pay attention to the notes on welding shield maintenance, given on page 22. When replacing the glass panels, use ONLY those parts supplied by Clarke International. The dark panel is a certified, specific optical class, and should not be exchanged for any other type.

The clear glass panel should be replaced when it becomes badly pitted.

WARNING:

NEVER look at an electric arc without eye protection as this can injure the eyes permanently. ALWAYS use a protection mask or welding helmet.

PREPARATION FOR USE

A. PREPARE THE WORK

MOST IMPORTANT!

It is VITAL that the workpiece is perfectly clean at the point of weld. Any coating, plating or corrosion MUST be removed, otherwise a good weld will be impossible to achieve.

B. SET THE CONTROLS



Three switches are provided....(1) ON/OFF, (2) MAX/MIN and (3) WIRE FEED.

The ON/OFF switch is self explanatory, but serves a secondary function. You will note that it is coloured amber. The switch doubles as a lamp, which will illuminate if the Thermal Overload intervenes. Please see the notes on page 21.

The MAX/MIN switch controls the welding current....and the 'WIRE FEED' rotary knob controls the speed of the wire feed to the nozzle.

In order to determine the correct settings for the job in hand....the following table serves as a useful reference.

Workpiece Thickness (mm)	Current Setting	Wire Feed
0 - 2.0	MIN	6
2.0 - 4.0	MAX	6

The 10-position wire speed control should be set to 6 to begin with, then adjusted as required. (See notes under 'Operation').

D. Trim the Welding Wire

Trim the welding wire so that it protrudes no more than 5mm from the end of the contact tip.

E. Attach the Earth Clamp

Attach the earth clamp to the workpiece, as close to the point of weld as possible, without it being intrusive.

Again, as with the 'welding point of contact', the earth clamp MUST be attached to CLEAN BARE METAL. Any coating, plating or corrosion MUST be removed, otherwise a good weld will be impossible to achieve.

Your welder is now fully prepared for welding.

⚡ WARNING!
ELECTRICITY CAN KILL
NEVER TOUCH LIVE ELECTRICAL COMPONENTS
DISCONNECT THE POWER SUPPLY BEFORE ALL INSPECTIONS AND
MAINTENANCE OPERATIONS
BEWARE HOT SURFACES.....ALWAYS LET THE POWER SUPPLY COOL DOWN
BEFORE ACCESSING INTERNAL COMPONENTS.

OPERATION

Plug the machine into the mains supply or switch on at the isolator, and, ensuring all precautions have been taken and with the machine set up correctly, lower the torch to the workpiece with one hand, whilst holding the welding mask in the other.

Approach the work with the tip at an angle of approx. 45° and pull the torch trigger fully.

As the electrode touches the workpiece, an arc will be struck....BUT, before it is struck, **COVER THE FACE WITH THE FACE MASK.**

Simultaneously gas will be generated, via the flux core in the wire, as the wire is fed into the molten pool.

Maintain a gap of approx. 5 - 7mm from the workpiece to the tip.

The speed of weld will depend upon the wire speed and welding current.

NOTES:

As MIG welding is an acquired skill, it is strongly advised that, if you are not fully familiar with this type of welding, you practise on a piece of material with the same characteristics as that of your workpiece, until you are satisfied with the result, and you have fine tuned your welder to produce a satisfactory weld.

One of the problems experienced with novice welders, is the welding wire sticking to the contact tip. This is as a result of the wire feed speed being too slow. It is always better therefore to start with too high a speed, and back off slightly, to avoid the possibility of the wire welding itself to the tip. This is the reason position 6 is recommended for start up.

The Wire Feed control is for fine tuning the wire speed. The speed of wire delivery will increase automatically as the current is increased from MIN to MAX, and vice versa. Therefore, once the ideal speed is achieved, by fine tuning, it should not be necessary to adjust this control when the welding current is changed.

Listen to the sound made. An irregular crackling sound denotes too high a wire speed. Decrease the speed until a regular, strong buzzing sound is heard.

Thermal Overload

Should your welder cut out for no apparent reason, it is probable that the THERMAL OVERLOAD has intervened. This is a safety device which shuts off the welder when the duty cycle has been exceeded. This is to prevent damage to the machine caused by overheating.

When this occurs, the ON/OFF switch will glow (amber). Allow the welder to cool, until the amber light extinguishes before resuming.

For details of the duty cycle...i.e. the length of time the machine may be used continuously, refer to the data and notes on page 27.

WELDING TIPS

1. Try to maintain the tip of the nozzle at an angle of approx. 45° and at a constant distance of approx 5-7mm from the workpiece.
2. Try to maintain a constant speed of movement with the torch.
3. Do not weld in windy conditions or in an area where ventilation is a problem, or where air flow fluctuates.
4. ALWAYS keep the wire and nozzle clean...NEVER use rusted wire.
5. Avoid sharp bends or kinks in the welding hose.
6. Whenever possible, clean out the wire liner with compressed air when replacing the wire spool.
7. Periodically remove the dust, using LOW PRESSURE compressed air, within the casing. Adequate heat dissipation is essential during the welders operation.

MAINTENANCE

Frequency of maintenance operations depends on the operating conditions, how intensively the welder is used, and how clean or dirty the welding site is (aggressive atmospheres, etc).

Always inspect the cables, both earth and torch cable, before use to ensure they are in perfect condition.

Ensure the earth clamp is clean and secured correctly to the cable.

Check the hose for security and serviceability.

As a general rule the covers should be removed and the transformer, and other components, should be inspected at least annually. Consult your CLARKE dealer for advice if necessary.

WELDING SHIELD

Always maintain the welding mask in good condition. If the clear glass protection lens becomes badly pitted, sufficient to interfere with vision, or cracked, have it replaced immediately.

Replacement clear and dark lenses are available from your Clarke dealer - see Parts Lists for details. NEVER use any dark filter lens other than that provided by CLARKE International, or one with the same certified 'Optical class' (degree of protection).

The shield should always be cleaned with a clean soft cloth after use, ensuring the lenses are clean. Remove any dust that may have accumulated and store it in a safe place where it cannot be damaged.

NEVER use a shield that is **not** in perfect condition.

TROUBLESHOOTING

Your **Clarke** Mig Welder has been designed to give long and trouble free service. If, however, having followed the instructions in this booklet carefully, you still encounter problems, the following points should help identify and resolve them.

PROBLEM	CAUSE	REMEDY
1. No "life" from welder	Check fuses and mains lead	a) Replace fuses as necessary If problem persists return welder to your local dealer b) Check fuse size
2. No wire feed	Motor malfunction	Return welder to your local dealer
3. Feed motor operates but wire will not feed	a) Insufficient Feed Roller Pressure b) Burr on end of wire c) Liner blocked or damaged d) Inferior wire e) Roller worn out	a) Increase roller pressure b) Re-cut wire square with no burr c) Clean with compressed air or replace liner. d) Use only good "clean" wire e) Replace roller
4. Wire welds itself to tip	a) Wire feed speed too low b) Wrong size tip	a) Unscrew tip, cut wire and fit new tip Increase wire speed before operating again b) Fit correct size tip
5. Wire feeds into 'birds nest' tangle	a) Wire welded to tip b) Wire liner damaged preventing smooth operation	a) As above plus reduce feed roller pressure so that if blockage occurs wire slips on roller i.e. no feed b) Renew wire liner
6. Loose coils of wire tangle around wire drum inside machine	Drum brake too slack	Tighten drum brake Caution: Do not over-tighten
7. Erratic wire feed	a) Drum brake too tight b) Feed roller worn c) Insufficient pressure on feed roller d) Wire dirty, rusty, damp or bent e) Liner partially blocked	a) Loosen drum brake slightly b) Check and replace if necessary c) Increase pressure on feed roller Caution: Do not over-tighten d) Re-cut wire and ensure it is clean e) Clean with compressed air
8. Poor quality welds	a) Insufficient gas at weld area b) Rusty, painted, damp, oil or greasy workpiece c) Rusty/dirty wire d) Poor earth contact	a) Check that gas is not being blown away by draughts and if so move to more sheltered weld area. If not increase gas supply b) Ensure workpiece is clean and dry c) Ensure wire is clean and dry d) Check earth clamp/workpiece conn
9. Welder cuts out whilst in use	Duty cycle exceeded (auto cut-out operates)	Allow welder to cool before continuing (Until amber light goes out) <i>Note: If duty cycle is continually exceeded, damage to the welder may result, and welder output is probably too small for application</i>

If you have any problems which cannot be resolved by reference to the above, or if you require spare parts for your welder please contact your local Clarke dealer.

PARTS DIAGRAM

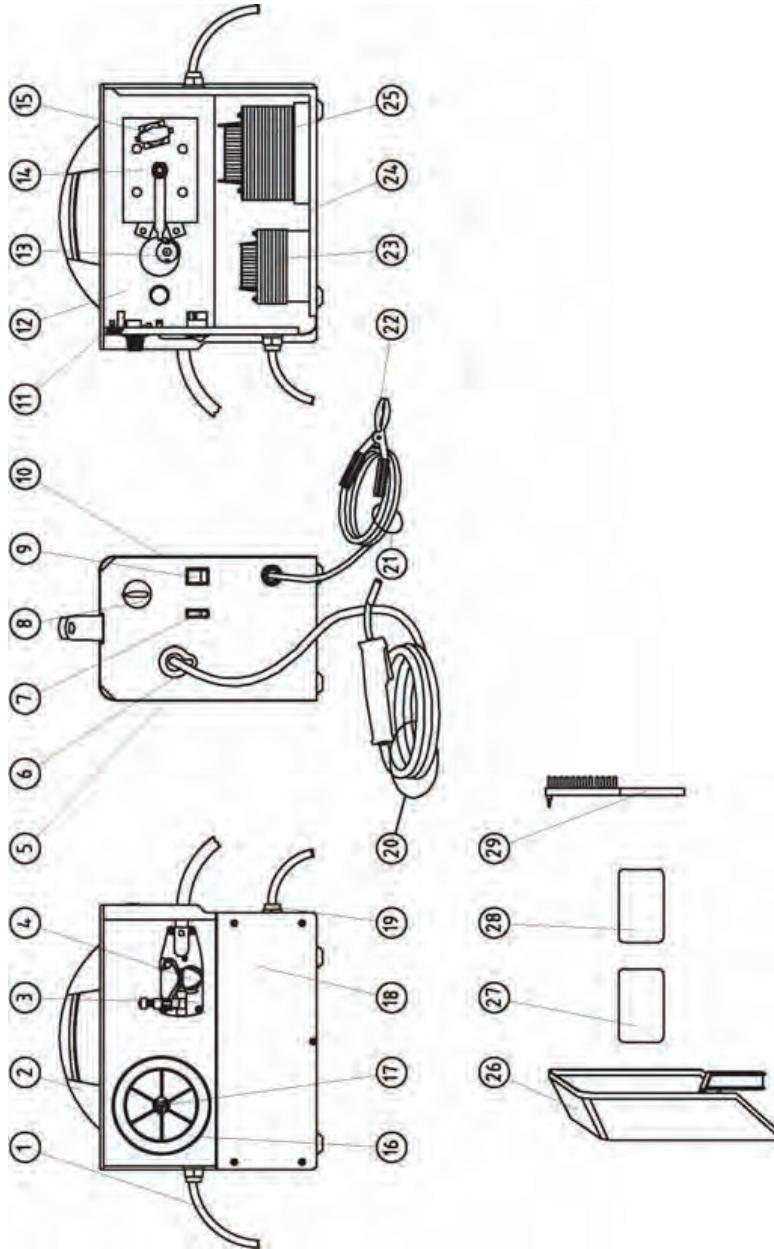

PARTS LIST

No.	Description	Part No.
01	Input Cable	EN20220068
02	Handle	EN21600030
03	Plastic Wire Feeder	EN44400018
04	Wire Feed Roll	EN33805074
05	Side Panel	EN33705482
06	Torch Grommet	EN21690458
07	Welding Current Switch	EN22200006
08	Potentiometer Knob	EN21690309
09	Yellow Pilot-light Switch	EN22200022
10	Right Upper Panel	EN33705324
11	Motor Control PC Board	EN22710047
12	Dividing Panel	EN33720159
13	Slow Motor	EN04600144
14	Rectifier	EN22400082
15	Complete Thermostat	EN04600126
16	Flux-cored Wire Spool	6000664
17	Kit Spool Holder	EN04600108
18	Left Side Panel	EN33705325
19	Cable Clamp	EN21605032
20	Torch	EN23000074
21	Earth Cable	EN43210021
22	Earth Clamp	EN22110005
23	Choke	EN44135097
24	Rear Panel	EN33700174
25	Transformer	EN44120092
26	Plastic Mask	EN21905018
27	Transparent Glass	EN21905020
28	Dark Glass	EN21905021
29	Hammer/Brush	EN21905011

WIRING DIAGRAM

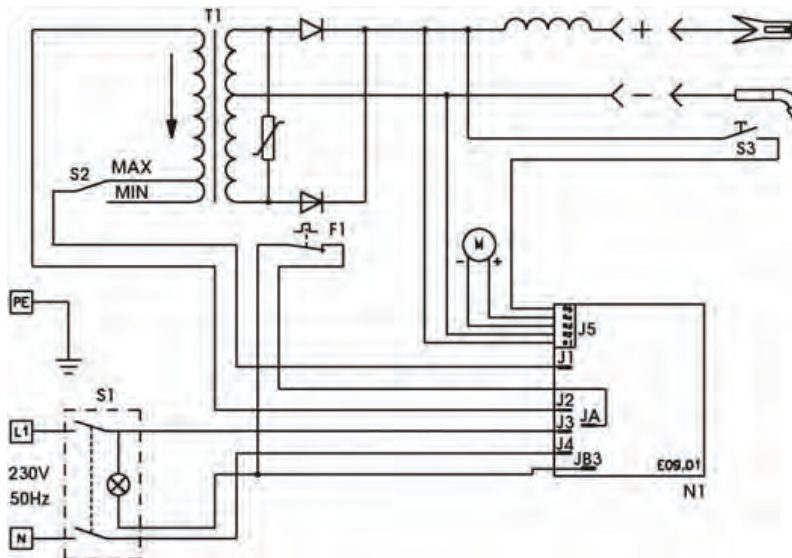

PARTS & SERVICE CONTACTS

For Spare Parts and Service, please contact your nearest dealer, or CLARKE International, on one of the following numbers.

PARTS & SERVICE TEL: 020 8988 7400

PARTS & SERVICE FAX: 020 8558 3622

or e-mail as follows:

PARTS: Parts@clarkeinternational.com

SERVICE: Service@clarkeinternational.com

SPECIFICATIONS

Power Supply	230V, 50Hz 1Ph
Fuse Rating	13Amps
Current Range	27 - 85Amps
Max. Metal Thickness	4mm
Welding Wire Sizes	0.9mm Flux Cored
Duty Cycle*	
MIN (27A)	100%
MAX (85A)	12%
Dimensions	380x175x350mm
Weight (net)	20.4kg
Part No.	6010109

Please note that the details and specifications contained herein, are correct at the time of going to print. However, CLARKE International reserve the right to change specifications at any time without prior notice. ALWAYS CONSULT THE MACHINE'S DATA PLATE

* **Duty Cycle:** Determines the machine 'down time'.

eg. Operating at MIN setting and welding thin material, the Duty Cycle is 100%. i.e. the welder may be used continuously.

At MAX setting, welding thick material (4mm), the Duty Cycle is 12%. This means that in ANY 10 minute period, the machine may be used for a total of 1.2 minutes and must have a down time of 8.8 minutes.

Always bear in mind that the welding current will be influenced by the thickness and characteristics of the workpiece...the thicker the workpiece, the greater the current.

ACCESSORIES

The following accessories are available from your Clarke dealer. Please quote the part numbers shown below:

Welding Wire Spool

Mini - 0.9mm (FLUX Core)

Part No.

6000664