

Clarke® CONTRACTOR®



4½" (115mm) ANGLE GRINDER

Model No. CON115

OPERATING & MAINTENANCE INSTRUCTIONS



GC0911



SPECIFICATIONS

Motor	230V~ 50Hz 1ph
Power Rating	1010Watts
Fuse Rating	13Amps
No Load Speed	11,000RPM
Wheel/Disc Dia.	115mm
Bore	22mm
Sound Power Level	103dBLWA
Sound Pressure Level	89.9dBLWA
Vibration Level	2.7m/s²
Weight (Net)	2.7kg
Part No.	6470140

Please note that the details and specifications contained herein, are correct at the time of going to print. However, CLARKE International reserve the right to change specifications at any time without prior notice.

Thank you for selecting this CLARKE 115mm (4½”) Angle Grinder. Before attempting to use the tool, please read this leaflet thoroughly and follow the instructions carefully. In doing so you will ensure the safety of yourself and that of others around you, and you can look forward to the Angle Grinder giving you long and satisfactory service.

GUARANTEE

This product is guaranteed against faulty manufacture for a period of 12 months from the date of purchase. Please keep your receipt therefore, as proof of purchase. This guarantee is invalid if the product is found to have been abused or tampered with in any way, or not used for the purpose for which it was intended. Faulty goods should be returned to their place of purchase, no product can be returned to us without prior permission. This guarantee does not effect your statutory rights.

CONTENTS

Specifications	2
Safety Precautions	3
Additional Precautions for Angle Grinders	5
Electrical Connections	6
Features	7
Assembly	7
Operation	8
Maintenance	8
Troubleshooting	9
Spare Parts & Service Contacts	9
Spare Parts	10
Declaration of Conformity	11

GENERAL SAFETY PRECAUTIONS

WARNING:

As with all machinery, there are certain hazards involved with their operation and use. Exercising respect and caution will considerably lessen the risk of personal injury. However, if normal safety precautions are overlooked or ignored, personal injury to the operator or damage to property, may result.

1. READ and BECOME FAMILIAR with the entire operating manual. Learn the tool's applications, limitations and the specific potential hazards peculiar to it.

2. ALWAYS ensure that ADEQUATE LIGHTING is available. A minimum intensity of 300 lux should be provided. Ensure that lighting is placed so that you will not be working in your own shadow.
3. CHECK FOR DAMAGE. Before using the tool, any damaged part should be checked to ensure that it will operate properly and perform its intended function. Check for alignment of moving parts, breakage of parts, mountings and any other condition that may affect the tools' operation. Any damage should be properly repaired or the part replaced. If in doubt, DO NOT USE the tool. Consult your local dealer.
4. DISCONNECT THE TOOL from the power supply before servicing and when changing accessories.
5. ALWAYS WEAR SAFETY GOGGLES manufactured to the latest European Safety Standards. Everyday eyeglasses do not have impact resistant lenses, and are NOT safety glasses.
6. KEEP WORK AREA CLEAN. Cluttered work areas and benches invite accidents.
7. DON'T FORCE the tool. It will do a better and safer job at the rate for which it was designed.
8. ALWAYS use a face or dust mask if operation is particularly dusty.
9. DRUGS, ALCOHOL & MEDICATION. Do not operate tool while under the influence of drugs, alcohol or any medication.
10. USE RECOMMENDED ACCESSORIES. The use of improper accessories could be hazardous.
11. NEVER LEAVE THE TOOL RUNNING UNATTENDED. Turn power OFF. Do not leave the tool until it comes to a complete stop.
12. AVOID DANGEROUS ENVIRONMENT. Don't use power tools in damp or wet locations or expose them to rain. Keep your work area well illuminated. DO NOT USE in an explosive atmosphere (near paint, flammable liquids etc).
13. KEEP CHILDREN AWAY. All visitors should be kept a safe distance from the work area, especially whilst operating the tool.
14. MAINTAIN TOOL IN TOP CONDITION. Keep tools clean for the best and safest performance. Follow maintenance instructions.
15. DON'T OVERREACH. Keep your proper footing/balance at all times. For best footing wear rubber soled footwear. Keep floor clear of oil, scrap wood, etc.
16. WEAR PROPER APPAREL. Loose clothing or jewellery may get caught in moving parts. Wear protective hair covering to contain long hair.
17. HANDLE WITH EXTREME CARE Do Not carry the tool by its electric cable, or yank the cable to disconnect it from the power supply.
18. AVOID ACCIDENTAL STARTING. Ensure the switch is OFF before plugging into mains.
19. BE AWARE that accidents are caused by carelessness due to familiarity. ALWAYS concentrate on the job in hand, no matter how trivial it may seem.
- 20 Guard against electric shock. Avoid body contact with earthed or grounded surfaces (e.g. Pipes, Radiators, Ranges, Refrigerators).

ADDITIONAL PRECAUTIONS FOR ANGLE GRINDERS

1. It is strongly advised that you wear ear protectors/defenders as the noise level during operation, depending upon the work being carried out, can exceed safe working levels.
2. Always wear a good pair of industrial gloves to avoid potential injury from sparks and debris.
3. Do not use the tool if the electric cable, plug or motor is in poor condition.
4. Keep the mains cable well away from the tool and ensure an adequate electrical supply is close at hand so that the operation is not restricted by the length of the cable.
5. Switch the tool OFF immediately the task is completed.
6. Never allow the ventilation slots in the tool to become blocked.
7. Do not attempt any electrical repair yourself. Consult a qualified electrician, or the Clarke Service Department on 0208 988 7400.
8. DO NOT cut through walls or cavities before checking for hidden electrical wires or water pipes etc.
9. Ensure the grinding wheel or cutting disc is fully tightened before use.
10. Do not use the tool in a confined space which may limit body movement.
11. Ensure the wheel/disc is not touching the work when switching ON.
12. Use only wheels/discs having a maximum operating speed of at least 11,000RPM.
13. Check the disc carefully for cracks or damage before operation. Replace cracked or damaged wheels/discs immediately.
14. Take care not to damage the spindle or wheel flanges as damage to these parts could result in wheel/disc breakage.
15. ALWAYS hold the tool firmly in BOTH hands.
16. Before using the tool on an actual workpiece, allow it to run briefly, checking for vibration which could indicate poor balance or installation of the wheel/ disc.
17. Use only wheels/discs designed for their specific function. DO NOT use cutting discs for grinding metal, or metal grinding wheels for cutting masonry.
18. When grinding, hold the grinder at an angle of 15-30° to the work surface.
19. NEVER use excessive force. It should only be necessary to use a little more than the weight of the tool. If the rotational speed drops abnormally, reduce pressure immediately. Forcing the tool and excessive pressure can cause dangerous disc breakage and/or damage to the tool.
20. NEVER use the tool with the guard removed. If the guard becomes damaged, it should be replaced.
21. NEVER twist the grinder when using Cutting Discs. Take care to ensure sparks do not fall on to sensitive areas. Be aware of the fire risk from sparks.
22. Never use Wheels/Discs other than 115mm diameter.
23. ALWAYS store and handle abrasive discs according to the manufacturer's instructions.

24. NEVER use a cutting-off wheel for side grinding.
25. ALWAYS ensure the work is properly secured or supported.
26. Do not allow flying sparks to fall on sensitive areas. Be aware of fire risks.
27. When not in use always store in a dry clean environment and out of reach of children.

Additionally, ALWAYS keep these instructions in a safe place for future reference.

ELECTRICAL CONNECTIONS

This product is provided with a 13 amp, 230 volt (50Hz), BS 1363 plug, for connection to a standard, domestic electrical supply. Should the plug need changing at any time, ensure that a plug of identical specification is used.

WARNING!

This appliance is of Double Insulation construction 

No earth conductor is provided. The two wires in the mains lead should be wired up in accordance with the following colour code:

Blue	—	Neutral
Brown	—	Live

Connect the BROWN coloured cord to the plug terminal marked a letter "L"
Connect the BLUE coloured cord to the plug terminal marked a letter "N"

If this appliance is fitted with a plug which is moulded on to the electric cable (i.e. non-rewireable) please note:

1. The plug must be thrown away if it is cut from the electric cable. There is a danger of electric shock if it is subsequently inserted into a socket outlet.
2. Never use the plug without the fuse cover fitted.
3. Should you wish to replace a detachable fuse carrier, ensure that the correct replacement is used (as indicated by marking or colour code).
4. Replacement fuse covers can be obtained from your local dealer or most electrical stockists.

Fuse Rating

The fuse in the plug must be replaced with one of the same rating (**13 amps**) and this replacement must be approved to BS1362.

If in doubt, consult a qualified electrician. Do not attempt any electrical repairs yourself.

Cable Extension

Do not use an extension longer than 10 metres and one where the conductors, are less than 1.5mm².

If used outdoors, ensure the extension cable is designed for outdoor use.

FEATURES (Ref. Fig 1)

1. ON/OFF Switch (A)

The ON/OFF switch (A) is provided with a safety lock button (B). The lock button (B) must be held in before the trigger can be squeezed in to the 'ON' position. This is designed to prevent accidental starting.

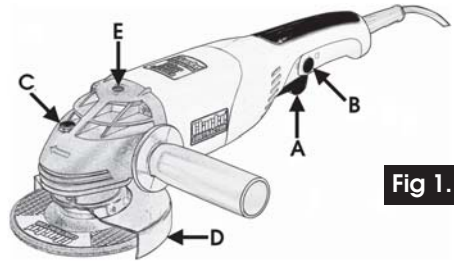

Fig 1.

2. Spindle Lock Button (C)

When pressed, this button, located on top of the head, is used to lock the spindle when attempting to unscrew and remove the outer flange (using the special tool provided), in order to mount or change the grinding wheel or cutting disc.

WARNING:

NEVER press the spindle lock button when starting the tool, and
NEVER press the button when the tool is operating.
DO NOT press the button until the wheel/disc has stopped completely

ASSEMBLY

1. Mounting the Grinding Wheel/Cutting Disc

Ensure the grinder is disconnected from the mains supply.

- 1.1 Unscrew and remove the outer flange by locking the spindle using the Spindle Lock button then use the flange tool supplied to turn the flange (right hand thread). It may then be screwed off by hand.
- 1.2 The grinding wheel supplied is the 'Depressed Centre' type. Mount it as shown in the Fig.2. i.e. with the depressed centre towards the motor
- 1.3 Ensuring the wheel sits snugly over the raised boss on the inner flange, screw on the outer flange with the centre boss facing inwards.
- 1.4 Tighten the flange using the tool provided, locking the spindle by pressing the Spindle Lock button, and taking care to ensure the wheel is still sitting snugly, centred over the flange bosses. Care should be taken also NOT to overtighten the outer flange.

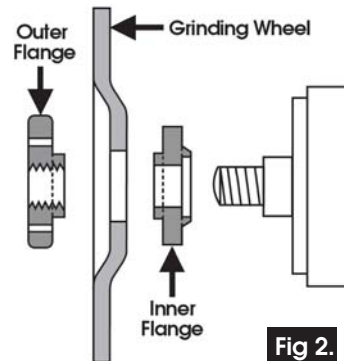

Fig 2.

WARNING:

Fig 2 shows the set up for a grinding wheel.
When attaching a cutting or diamond disc YOU MUST REVERSE the outer flange so that the boss faces OUTWARDS.

2. Hand Grip

A threaded hole 'E', on the top, left or right hand side of the gear housing, is provided so that the hand grip may be screwed in, as required, to provide left or right hand control of the tool.

OPERATION

IMPORTANT: DO NOT plug the tool in to the mains, unless you have ensured it is switched OFF and the guard is set to the desired position.

The blade guard can be rotated about its axis and is locked by a single hex head screw (see Fig.3). Slacken the screw, using the tool supplied, grasp the guard firmly and move to the desired position, ensuring maximum protection for the operator without impeding the work being carried out. The screw must be tightened when the guard is in the desired position.

NOTE: When the tool is new, it may be necessary to slacken the three cross head screws, in addition to the securing screw, in order to free off the guard. This can only be achieved with the cutting disc removed. Once the guard has been moved, the three screws must be retightened, and should not require slackening for this purpose again. Before fitting the cutting disc, try moving the guard again ensuring only the locking screw is loose, then with the guard in the desired position, retighten the locking screw.

The hand holding the tool body will control the ON/OFF trigger switch, whilst the other hand grasps the hand grip and guides the tool over the workpiece.

Hold the tool firmly but not tightly. Allow the tool to do the work...DO NOT force the wheel on to the workpiece.

The ON/OFF trigger switch (A) in Fig 1, is provided with a safety lock button (B), to prevent accidental starting. To operate, fully depress the trigger switch and depressing the safety lock button (B). To stop, release the lock button, and the trigger switch. The grinder will slow down and stop.

Whenever changing discs, always run the grinder at no load speed to check for irregularities before beginning work.

Securing
Screw



MAINTENANCE

IMPORTANT: Before carrying out any maintenance tasks, ALWAYS disconnect the tool from the mains electrical supply.

Before Each Use

1. Always inspect the tool before use and ensure it is in top condition.
2. Ensure all air vents are clear, use compressed air to clean the tool where possible. (Always wear protective goggles when cleaning with compressed air.). Take all necessary precautions regarding the use of compressed air.
3. Check the power cable to ensure it is sound and free from cracks, bare wires etc.
4. Ensure the grinding wheel or cutting disc is perfectly sound, free from cracks or damage in any way.

TROUBLESHOOTING

Problem	Possible Cause	Remedy
Tool will not operate	<ol style="list-style-type: none"> 1. No supply 2. Switch is faulty 3. Fuse blown 4. Motor faulty 	<ol style="list-style-type: none"> 1. Check supply and rectify where necessary. 2. Consult your Clarke dealer 3. Check and replace if necessary. If condition persists, consult your dealer 4. Consult your Clarke dealer.
Motor runs but disc will not	<ol style="list-style-type: none"> 1. Flange nut not tight 2. Gear shaft or key broken 	<ol style="list-style-type: none"> 1. Tighten flange nut 2. Consult your Clarke dealer
Heavy internal Sparking	<ol style="list-style-type: none"> 1. Faulty motor 	<ol style="list-style-type: none"> 1. Consult your Clarke dealer
Motor gets hot	<ol style="list-style-type: none"> 1. Work load too heavy 2. Low supply voltage 	<ol style="list-style-type: none"> 1. Reduce force applied to tool 2. Ensure supply voltage is correct. If extension cable is used, ensure it is of the correct value, and is fully unreeled
Excessive vibration	<ol style="list-style-type: none"> 1. Wheel not mounted correctly 2. Bearings worn 	<ol style="list-style-type: none"> 1. Check and rectify 2. Consult your Clarke dealer

SPARE PARTS AND SERVICE CONTACTS

For Spare Parts and Service, please contact your nearest dealer, or CLARKE International, on one of the following numbers.

PARTS & SERVICE TEL: 020 8988 7400

PARTS & SERVICE FAX: 020 8558 3622

or e-mail as follows:

PARTS: Parts@clarkeinternational.com

SERVICE: Service@clarkeinternational.com

PARTS DIAGRAM

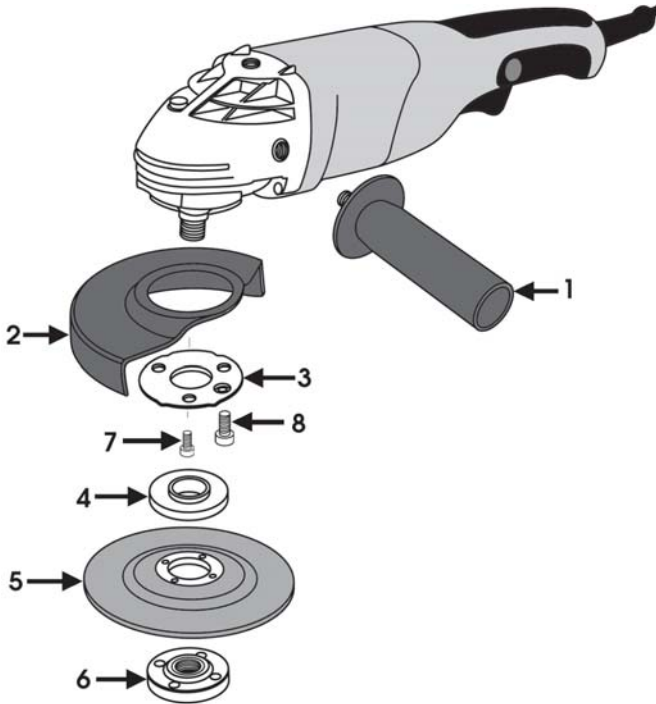

SPARE PARTS

1.	Hand Grip	HTCON11501
2.	Guard	HTCON11502
3.	Friction Washer	HTCON11503
4.	Inner Flange	HTCON11504
5.	Grinding Wheel/Cutting Disc	(See below)
6.	Outer Flange	HTCON11506
7.	Guard Securing Screw	HTCON11507
8.	Guard Locking Screw	HTCON11508
-	Flange Release Tool	HTCON11509

The following Grinding Wheels/ Cutting Discs are available from your Clarke dealer.

1.	Metal Grinding (DPC) 115mm x 6mm thickness	Part No:	6470705
2.	Metal Cutting (DPC) 115mm x 3mm thickness	Part No:	6470775
3.	Masonry Cutting (DPC) 115mm x 3mm thickness	Part No:	6470735

ClarkeTM
INTERNATIONAL



This is an important document and should be retained

DECLARATION OF CONFORMITY

We declare that this product complies with the following standards/directives:

- **98/37/EC**
- **89/336/EEC**
- **73/23/EEC**
- **EN 50 144**

Description: **ANGLE GRINDER**

Model No: **CON115**

Serial (Batch) No: **See Product Date Plate**

Signed: 

Clarke[®] **INTERNATIONAL**
Hennall Street, Epping, Essex CM16 4LG