

CLARKE[®]

METALWORKER



ENGLISH WHEEL

Model No. EW-705

PART NO: 7627900

OPERATING & ASSEMBLY INSTRUCTIONS

INTRODUCTION

Thank you for purchasing this CLARKE English Wheel.

The EW705 is suitable for forming and shping light gauge steel and aluminium panels and for removing dents, smoothing hammer marks, flattening welds etc. Pressure is applied by adjusting the lower anvil roller. Standard anvil rollers are supplied as listed in the specification.

Before attempting to use this product, please read this manual thoroughly and follow the instructions carefully. In doing so you will ensure the safety of yourself and that of others around you, and you can look forward to your purchase giving you long and satisfactory service.

GUARANTEE

This product is guaranteed against faulty manufacture for a period of 12 months from the date of purchase. Please keep your receipt which will be required as proof of purchase.

This guarantee is invalid if the product is found to have been abused or tampered with in any way, or not used for its intended purpose.

Faulty goods should be returned to their place of purchase, no product can be returned to us without prior permission. This guarantee does not effect your statutory rights.

TABLE OF CONTENTS

INTRODUCTION	2
GUARANTEE	2
GENERAL SAFETY RULES	3
OVERVIEW	4
ASSEMBLY	5
BEFORE STARTING WORK	8
OPERATION	9
MAINTENANCE	9
SPECIFICATION	10
COMPONENT PARTS LIST	11

GENERAL SAFETY RULES

WORK AREA

1. **Keep the work area clean and well lit.** Cluttered and dark areas invite accidents.
2. **Keep children and bystanders away while operating this tool.** Distractions can cause you to lose control.

PERSONAL SAFETY

1. **Stay alert, watch what you are doing and use common sense when you are using this equipment.** Do not operate this tool when you are tired, ill or under the influence of alcohol, drugs or medication.
2. Safety equipment such as gloves and non-skid shoes used for appropriate conditions will reduce personal injuries.
3. **Do not over-reach.** Keep your proper footing and balance at all times.
4. **Concentrate on the job in hand,** no matter how trivial it may seem. Be aware that accidents are caused by carelessness due to familiarity.
5. **Do not wear loose clothing or jewellery** which may get caught in moving parts. Wear protective hair covering to contain long hair. For best footing, wear rubber soled footwear. Keep floor clear of oil, scrap wood, etc.
6. Keep equipment clean for the best and safest performance. Check for misalignment or binding of moving parts, broken parts, or any condition that may affect the tool's operation. If damaged, have the tool repaired before use.
7. **Always hold the workpiece securely.** Large workpieces should always be well supported to avoid loss of control.
8. Secure the English Wheel frame to the floor to prevent it from moving or tipping over in use.
9. Sheet metal may have sharp edges. Always wear gloves when handling sheet metal and use caution when bending and cutting.
10. Rollers are heavy, take care when handling.

SERVICING

1. **When necessary, have equipment repaired by a qualified person using identical replacement parts.** This will ensure that the safety of the tool is maintained.

Please keep these instructions in a safe place for future reference.

OVERVIEW

The following main components are supplied loose, accompanied by a fixings pack containing nuts, bolts, washers, handle balls, handle arms and locking knob.

- Upper Frame (1)
- Front Upright (16)
- Rear Upright (17)
- Link Beam (19)
- Front Legs (15)
- Backing Plate (18)
- Roller Storage Rack (13) & Locking Bar (12)
- Upper Roller (2)
- Lower Anvil Rollers (11) with spindles
- Roller Support Yoke (8)
- Support Tube (5)
- Adjusting Rod (14)
- Eccentric Shaft & Handle (6/7)

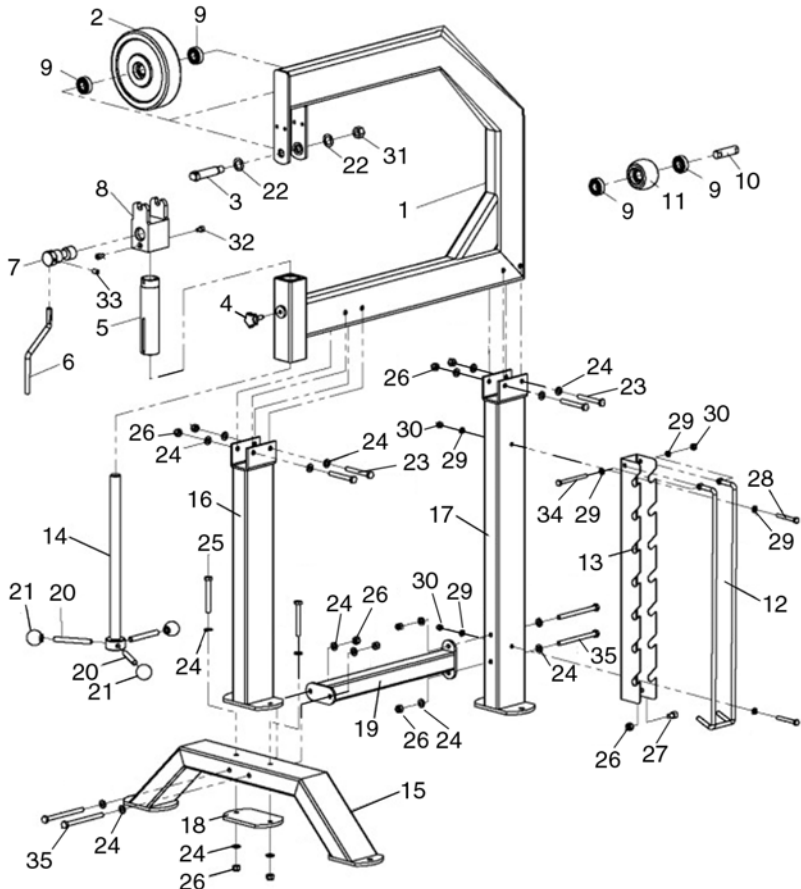

ASSEMBLY

This EW-705 components are shown below.

1. Unpack the components on the floor where the unit will be installed.
 - When unpacking, check for damage or shortages etc. Any found should be reported to your CLARKE dealer where the product was originally purchased.
 - Assemble all the frame components loosely to ensure all bolt holes will line up, then tighten everything securely when the assembly is complete.
2. Assemble the front upright (16) to the front legs (15), with the backing plate (18), 85 mm bolts (25), nuts (26) & washers (24).
3. Next connect the link beam (19) to the front legs with two 130 mm bolts (35), washer (24) and nuts (26).

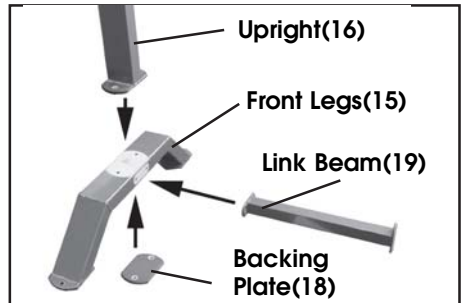

4. Attach the link beam (19) to the rear upright (17) with two 130 mm bolts (35), nuts (26) & washers (24).
5. Bolt the anvil roller storage rack (13) to the rear upright (17) using two 65 mm bolts (28), washers (29) and nuts (30).

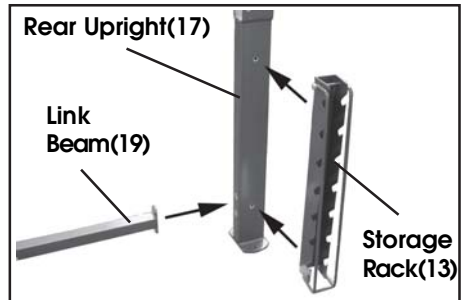

6. With the help of an assistant, lift the upper frame (1) into position on the front and rear legs and secure with the 80 mm bolts (23), nuts (26) & washers (24). Tighten all nuts & bolts securely.



7. Lower the roller yoke assembly into the mounting hole in the frame.
8. Screw the locking knob (4) into the threaded hole on the upper frame (1). Lift and turn the support tube (5) assembly so that the locking knob (4) seats into the slot in the support tube. Tighten the knob.
9. Insert the eccentric shaft (7) with its handle (6) into the hole in the yoke (8).
11. Thread each handle lever (20) into the adjusting rod (14) and securely tighten.
12. Offer the adjusting rod (14) into the under side of the frame (1) and screw it into the support tube already in position.
13. Take the upper roller (2) and position it within the bracket of the upper frame (1). Pass the axle (3) through the assembly and secure with two washers (22) and nut (31).
 - Note that a 24mm socket will be required for the nut and a 17mm open spanner for the end of the axle.
16. Slide the spindle into each of the anvil rollers and store the rollers on the roller storage rack (13).
 - Place them in order of size on the rack. (Each roller has the size stamped on it).

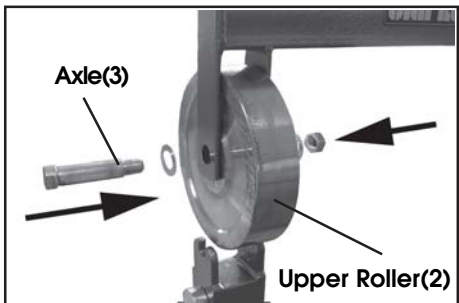
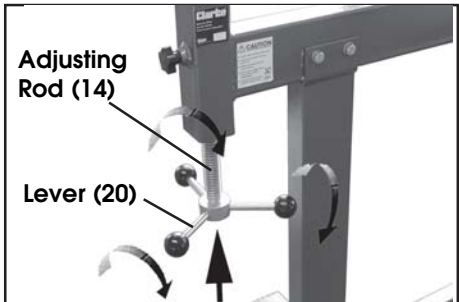
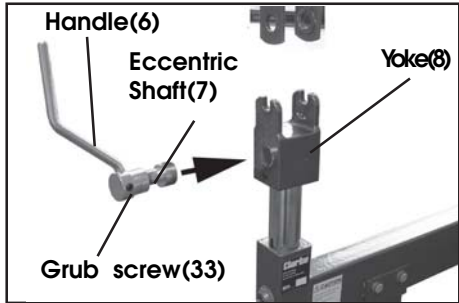
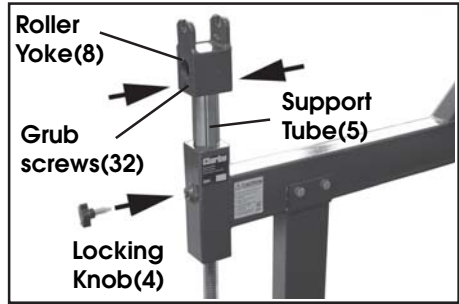

MOUNTING THE FRAME TO THE FLOOR

The foot of each leg has a bolt hole which allows the English Wheel to be fixed to a suitably level floor.

With the help of at least one other person, move the assembled unit to the chosen location where it will be mounted.

Measure the size of the mounting holes in the front leg and back stands, then drill appropriate sized holes to accommodate the mounting bolts or screws (fixings not supplied).

BEFORE STARTING WORK



CAUTION! METAL EDGES CAN BE VERY SHARP. AVOID INJURIES BY WEARING APPROVED SAFETY GLOVES

Check that all component parts are secure and that the rollers turn freely.

Practice on some scrap metal before attempting work on the actual stock workpiece. Using an English Wheel successfully requires a considerable degree of acquired skill and experience.

The English Wheel can be used with rollers of various radii in order to suit the task to be carried out. These various radii allow different curves to be formed in the workpiece.

SELECTING THE LOWER ANVIL ROLLER

1. Select the appropriate lower anvil roller from the storage rack and place it with its spindle on the roller yoke. When selecting the roller, consider the type and hardness of the metal being formed as well as the desired curvature of the metal.

- All the rollers have the same diameter (75 mm) and the same width (50.8 mm), but as can be seen from the picture, the working surface radii are different.

Note that these are always expressed in imperial units.

- The flat roller is used for smoothing, as against forming curved profiles.
- Smaller radius rollers produce a tighter curve on the workpiece than the larger radius rollers. It is also common practice to change rollers during operation in order to achieve a specific profile.

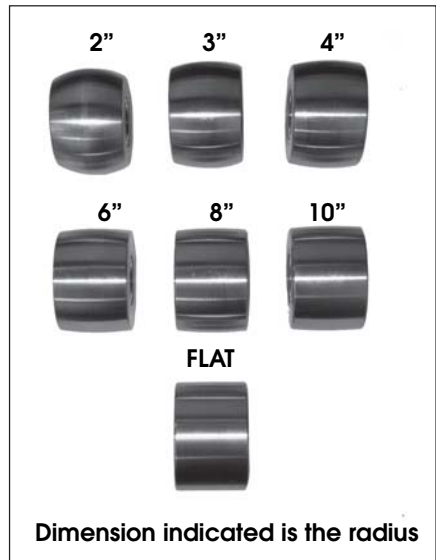

OPERATION

1. Insert the sheet metal workpiece between the upper and lower anvil rollers.
2. With the eccentric shaft handle in the horizontal (slack) position, turn the adjusting rod to raise the anvil roller yoke and gently pinch the workpiece.

Minor adjustments to the gap between the rollers can be made by moving the eccentric shaft up or down.

- Pinching it tightly will make it harder to pass the metal through the rollers and may cause unwanted creasing.
- Pinching it loosely makes work easier and therefore more accurate. However, it may take more passes to form the required shape.

3. Before working, turn the locking knob clockwise until tight.
4. Begin forming the metal by pushing and pulling it through the rollers.
5. If minor adjustments are required between the rollers, loosen the handle. This causes the eccentric shaft to slightly raise or lower the anvil roller.

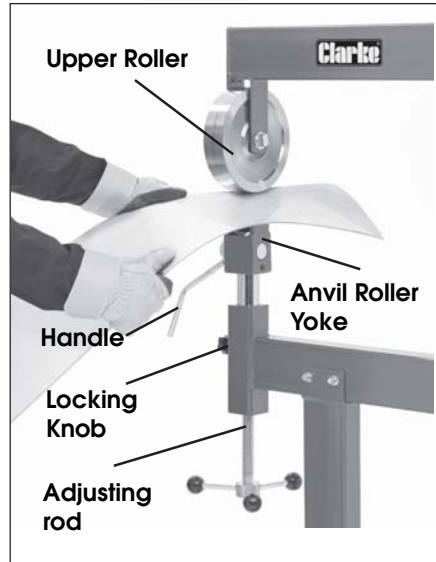

MAINTENANCE

Always inspect the wheel and anvil rollers before use and ensure they are in top condition. Check that all moving parts do so smoothly and freely.

After use, keep the rollers clean and occasionally lubricate moving parts with a light oil. This will also inhibit any corrosion of the metal components.

For any technical problems contact your CLARKE International Service Department on 020-8988-7400.

SPECIFICATION

Item	Specification
Weight	62.3 kg
Dimensions (W x D x H)	953 x 860 x 1508 mm
Throat Capacity	705 mm (28") (measured from centre of wheel surface)
Anvil Roller Dimensions	
2" Radius	75 dia x 50.8 wide x 50 radius (mm)
3" Radius	75 dia x 50.8 wide x 75 radius (mm)
4" Radius	75 dia x 50.8 wide x 100 radius (mm)
6" Radius	75 dia x 50.8 wide x 150 radius (mm)
8" Radius	75 dia x 50.8 wide x 203 radius (mm)
10" Radius	75 dia x 50.8 wide x 254 radius (mm)
Flat Profile	75 dia x 50.8 wide x 0 radius (mm)

Please note that the details and specifications contained herein, are correct at the time of going to print. However, CLARKE International reserve the right to change specifications at any time without prior notice.

COMPONENT PARTS LIST

No	Part No	Description	Qty
1	SMEW70501	Upper Frame	1
2	SMEW70502	Upper Roller	1
3	SMEW70503	Upper Roller Shaft	1
4	SMEW70504	Locking Knob	1
5	SMEW70505	Support Tube	1
6	SMEW70506	Handle	1
7	SMEW70507	Eccentric Shaft	1
8	SMEW70508	Roller Yoke	1
9	SMEW70509	Bearing 5004-ZZ	16
10	SMEW70510	Roller Spindle	7
11	SMEW70511	Anvil Roller **	1
12	SMEW70512	Retaining Bracket	1
13	SMEW70513	Anvil Roller Storage Rack	1
14	SMEW70514	Adjusting Rod	1
15	SMEW70515	Front Legs	1
16	SMEW70516	Front Upright	1
17	SMEW70517	Rear Upright	1
18	SMEW70518	Backing Plate	1

No	Part No	Description	Qty
19	SMEW70519	Link Beam	1
20	SMEW70520	Handle Lever	3
21	SMEW70521	Ball Handle	3
22	SMEW70522	Washer 20 mm	2
23	SMEW70523	Bolt, M10 x 80 mm	4
24	SMEW70524	Washer, 10 mm	20
25	SMEW70525	Bolt, M10 x 85 mm	2
26	SMEW70526	Nut, M10	11
27	SMEW70527	Bolt, M10 x 15 mm	1
28	SMEW70528	Bolt, M8 x 65 mm	2
29	SMEW70529	Washer, 8 mm	6
30	SMEW70530	Nut, M8	3
31	SMEW70531	Nut, M16	1
32	SMEW70532	Grub screw M8 x 12 mm	2
33	SMEW70533	Grub screw, M10 x 16 mm	1
34	SMEW70534	Bolt, M8 x 95 mm	1
35	SMEW70535	Bolt, M10 x 130mm	4

****Anvil rollers are supplied in the following sizes and are available individually**

11a	SMEW70536	Anvil Roller 2" rad	1
11b	SMEW70537	Anvil Roller 3" rad	1
11c	SMEW70538	Anvil Roller 4" rad	1
11d	SMEW70539	Anvil Roller 6" rad	1

11d	SMEW70540	Anvil Roller 8" rad	1
11e	SMEW70541	Anvil Roller 10" rad	1
11f	SMEW70542	Anvil Roller (flat)	1

A SELECTION FROM THE VAST RANGE OF

Clarke®

QUALITY PRODUCTS

AIR COMPRESSORS

From DIY to industrial, Plus air tools, spray guns and accessories.

GENERATORS

Prime duty or emergency standby for business, home and leisure.

POWER WASHERS

Hot and cold, electric and engine driven - we have what you need

WELDERS

Mig, Arc, Tig and Spot. From DIY to auto/industrial.

METALWORKING

Drills, grinders and saws for DIY and professional use.

WOODWORKING

Saws, sanders, lathes, mortisers and dust extraction.

HYDRAULICS

Cranes, body repair kits, transmission jacks for all types of workshop use.

WATER PUMPS

Submersible, electric and engine driven for DIY, agriculture and industry.

POWER TOOLS

Angle grinders, cordless drill sets, saws and sanders.

STARTERS/CHARGERS

All sizes for car and commercial use.

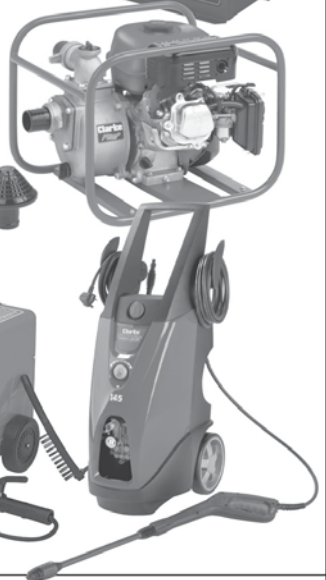

PARTS & SERVICE: 020 8988 7400

E-mail: Parts@clarkeinternational.com or Service@clarkeinternational.com

SALES: UK 01992 565333 or Export 00 44 (0)1992 565335

Clarke® INTERNATIONAL Hemnall Street, Epping, Essex CM16 4LG
www.clarkeinternational.com