

# Clarke<sup>TM</sup>



## 20m Retractable Water Hose Reel

Model WHR20

PART NO: 7956020

## USER GUIDE

---

## INTRODUCTION

---

Thank you for purchasing this CLARKE Hose Reel.

Please read this manual thoroughly and follow the instructions carefully. Before attempting to use the hose reel, thoroughly familiarise yourself with the reel & its operation. In doing so you will ensure the safety of yourself and that of others around you, and you can look forward to the hose reel giving you long and satisfactory service.

---

## GUARANTEE

---

This product is guaranteed against faulty manufacture for a period of 12 months from the date of purchase. Please keep your receipt which will be required as proof of purchase.

This guarantee is invalid if the product is found to have been abused or tampered with in any way, or not used for the purpose for which it was intended.

Faulty goods should be returned to their place of purchase, no product can be returned to us without prior permission. This guarantee does not effect your statutory rights.

---

## PARTS & SERVICE

---

For spare parts and service, please contact your nearest dealer, or CLARKE International, on one of the following numbers.

**PARTS & SERVICE TEL: 020 8988 7400 / FAX: 020 8558 3622**

**or e-mail as follows:**

**PARTS: [Parts@clarkeinternational.com](mailto:Parts@clarkeinternational.com)**

**SERVICE: [Service@clarkeinternational.com](mailto:Service@clarkeinternational.com)**

---

## ENVIRONMENTAL PROTECTION

---



Do not dispose of this product with general household waste. It should be disposed of at a recognised disposal facility in accordance with local authority guidelines.

---

## SPECIFICATION

---

This CLARKE retractable hose reel incorporates a spring-driven, automatic rewind with locking ratchet mechanism. It can be installed in any location using the integral mounting bracket and can be swivelled to cover a wide range of movement. The hose reel is supplied with an integral mounting bracket & four 8 x 70mm expanding sleeve anchor bolts for fixing to a building structure.

Model: ..... WHR20  
Part No: ..... 7956020  
Inlet Hose Length ..... 1.98m  
Outlet Hose Length ..... 20m  
Maximum Rated Pressure: ..... 6 bar / 88psi  
Hose end fittings ..... 'Hoselock' type with  $\frac{3}{4}$  &  $\frac{1}{2}$ " Npt tap adaptors

---

## CONTENTS

---

### *IMPORTANT*

Before commencing please check contents and advise immediately of any shortages.

FIGURES IN BRACKETS REFER TO DIAGRAM & PARTS LIST ON PAGE 7

- 1 x Hose Reel
- 1 x Mounting Bracket (10)
- 1 x Pivot Pin (11)
- 1 x Fixings pack (contains four 8 x 70mm sleeve anchor bolts)
- 1 x User Guide (this document)



---

## GENERAL SAFETY RULES

---

1. **NEVER** exceed the rated operating pressure for this equipment - 6bar / 88psi.
2. **NEVER** allow children to use the hose reel. Keep children clear of the work area at all times.
3. **NEVER** allow the hose to retract freely. It should always be restrained to prevent the hose from whipping, with resultant damage to persons or property.
4. **ALWAYS** check for damage before using the hose. Any damage should be properly repaired or the part replaced. Consult your local dealer.
5. **ALWAYS** ensure trailing hose does not constitute a trip hazard.

---

## INSTALLATION

---

The hose reel may be mounted to a wall, floor or ceiling rafter as required. Ensure the mounting hardware and the mounting position is of sufficient strength to support the hose and reel, plus the force required to extend the hose.

Choose a suitable mounting position close enough to the water supply that the hose can be conveniently connected using the shorter length of hose supplied and from where, the water can be turned on & off. The ideal position will be approx 1 metre above the ground. Expanding sleeve anchor bolts are supplied for attaching to the building structure. Bolt holes in the mounting bracket are positioned at 132mm and 72mm centres for the M8 fixing bolts supplied.

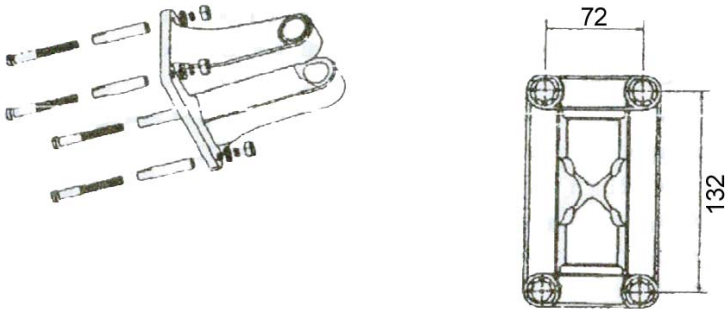

Fig. 1

When the reel is secured in position, attach the hose coming from the water supply to the inlet side of the hose reel.

---

## OPERATION

---

Check the hose reel for correct operation, as follows:

Gently pull out the hose - a series of clicks will be heard, every half revolution of the drum.

When a click is heard, release the hose. It should be held by the ratchet. Continue to pull out the hose, and after a series of clicks, at various lengths, release it to check the operation of the ratchet.

To release the ratchet, give the hose a brief pull, and allow the hose to retract, under control, until the stopper rests on the hose guide. Do not suddenly let go of the hose. If the hose becomes twisted, pull out a long length of hose before retracting so as to smooth out the hose.

When not in use, avoid leaving the reel exposed to very low temperatures which will make the hose less flexible and difficult to retract.

Avoid contact with chemicals and solvents such as acetone, white spirit etc.

The hose supplied with the reel can be used with the 'Hoselock' style end fittings supplied in Fig 2, and with any combination of similar fittings to connect to sprinklers etc.



**Fig. 2**

# MAINTENANCE



**WARNING:** Before carrying out any maintenance tasks always be sure to turn off the water supply to the hose reel and release any pressure in the hose.

Periodically, check the hose for wear and damage. Any damage or leaks should be repaired before further use. If the hose becomes very dirty, clean it with soapy water before retraction into the reel.

Store the reel and hose in a sheltered position out of direct sunlight.

## Swivel Seal Replacement

The swivel seals will need replacing from time to time due to normal wear & tear. This is carried out as follows:

1. Remove the three side cover securing screws & lift off the cover to reveal the swivel assembly.
2. Undo & remove the three swivel hub securing screws 'A' and pull out the swivel hub 'B'.
3. Renew the two O-ring seals and re-assemble in reverse order.

**IMPORTANT:** DO NOT overtighten the swivel seal securing screws as damage to the plastic screw threads is irreparable.

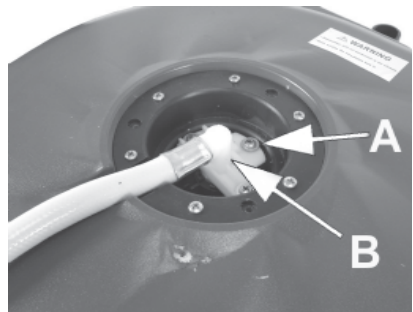

# PARTS DIAGRAM

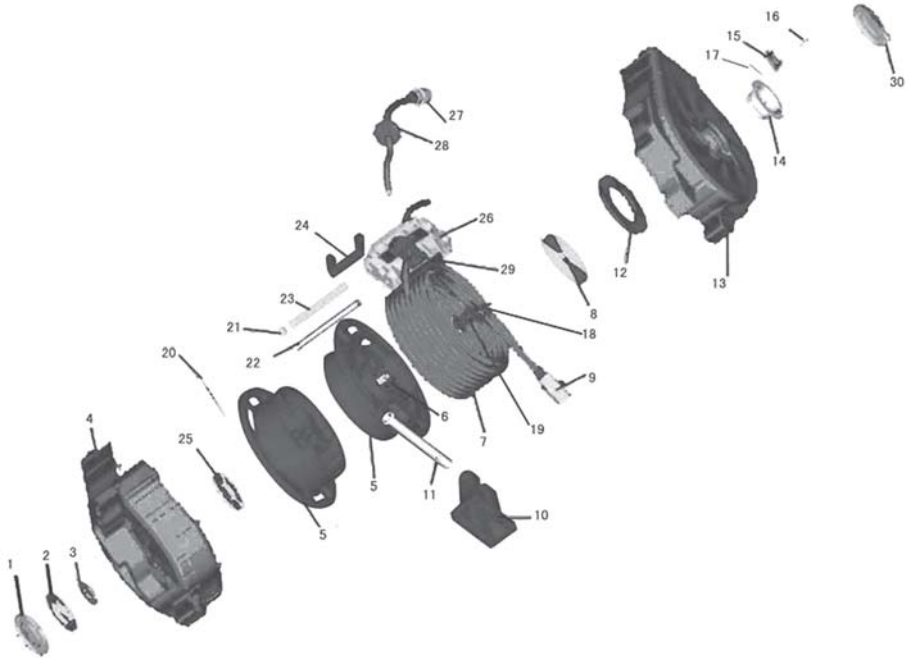

No.	Description	Part No.	No	Description	Part No.
1	Left End Cover	WHR20001	16	Ratchet Pin	WHR20016
2	Spring Tensioning Disc	WHR20002	17	Ratchet Pin Guide	WHR20017
3	Gear Cover	WHR20003	18	Inlet Hose Connector	WHR20018
4	Casing Left Half	WHR20004	19	Outlet Hose Connector	WHR20019
5	Hose Reel	WHR20005	20	Synchronising Belt	WHR20020
6	Central Spool	WHR20006	21	Small Gear for above	WHR20021
7	Hose	WHR20007	22	Guiding Pole	WHR20022
8	Coil Spring	WHR20008	23	Screw Mandrel	WHR20023
9	Inlet Quick connector	WHR20009	24	Handle Bar	WHR20024
10	Mounting Bracket	WHR20010	25	Large Gear for Belt	WHR20025
11	Aluminium Tube	WHR20011	26	Front Cover	WHR20026
12	Track Disc	WHR20012	27	Connector	WHR20027
13	Casing Right Half	WHR20013	28	Stopper	WHR20028
14	Plastic Boss	WHR20014	29	Guide Set	WHR20029
15	Ratchet Pawl Hosing	WHR20015	30	Right End Cover	WHR20030

# A SELECTION FROM THE VAST RANGE OF

# Clarke®

## QUALITY PRODUCTS

### AIR COMPRESSORS

From DIY to industrial, Plus air tools, spray guns and accessories.

### GENERATORS

Prime duty or emergency standby for business, home and leisure.

### POWER WASHERS

Hot and cold, electric and engine driven - we have what you need

### WELDERS

Mig, Arc, Tig and Spot. From DIY to auto/industrial.

### METALWORKING

Drills, grinders and saws for DIY and professional use.

### WOODWORKING

Saws, sanders, lathes, mortisers and dust extraction.

### HYDRAULICS

Cranes, body repair kits, transmission jacks for all types of workshop use.

### WATER PUMPS

Submersible, electric and engine driven for DIY, agriculture and industry.

### POWER TOOLS

Angle grinders, cordless drill sets, saws and sanders..

### STARTERS/CHARGERS

All sizes for car and commercial use.

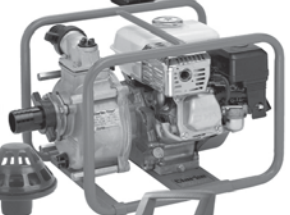

For spare parts and servicing, please contact your nearest dealer, or Clarke International on

**020 8988 7400**

e-mail: [Parts@clarkeinternational.com](mailto:Parts@clarkeinternational.com) e-mail: [Service@clarkeinternational.com](mailto:Service@clarkeinternational.com)

**Clarke** INTERNATIONAL  
Hemnal Street, Epping, Essex CM16 4LG