

CLARKE®



GC0717

Garden Cart With Removable Liner

Model No: GT3
Part No: 3400185

Thank you for purchasing this CLARKE Garden Cart with removable liner, which is designed for domestic and light industrial use only.

Please read this instruction sheet thoroughly and follow the instructions carefully. In doing so you will ensure the safety of yourself and that of others around you and will also ensure that the Garden Cart will give you long and satisfactory service.

Please keep these instructions in a safe place for future reference.

CLARKE GUARANTEE

This CLARKE product is guaranteed against faulty manufacture for a period of 12 months from the date of purchase. Please keep your receipt as proof of purchase.

This guarantee is invalid if the product is found to have been abused or tampered with in any way, or not used for the purpose for which it was intended.

Faulty goods should be returned to their place of purchase. No product can be returned to us without prior permission.

This guarantee does not effect your statutory rights.

SAFETY PRECAUTIONS

⚠ WARNING! Read these instructions before using the equipment. **⚠**

- **BEFORE** attempting to transport any load, ensure you are physically able to do so.
- **DO NOT** exceed the maximum working load for this garden cart - **150Kg**.
- **DO NOT** leave the cart on a gradient without first securely chocking the wheels.
- **DO NOT** allow children to play with or ride in the cart.
- **NEVER** use the cart if any of the tyres are deflated.
- **NEVER** use the cart to transport personnel or animals.
- **ALWAYS** inspect the cart for signs of wear or damage before use.
- **ALWAYS** ensure the load is evenly distributed and is perfectly stable.

Please Note that details and specifications herein, are correct of time of going to print.
However CLARKE International reserve the right to change specifications at any time without prior notice.
Copyright CLARKE International All rights Reserved 04/2006.

ASSEMBLY

1.

Fig.1

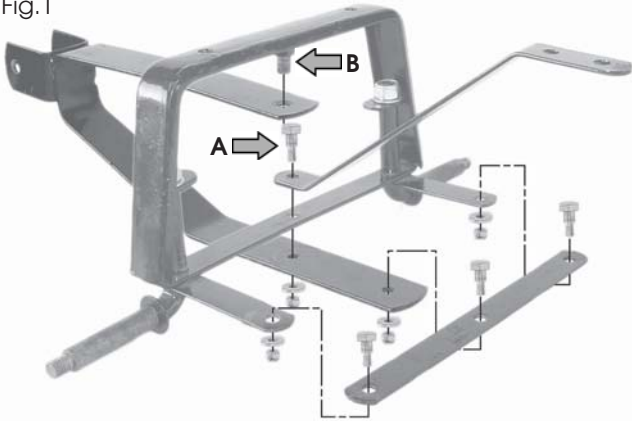

Assemble the steering linkage parts as shown in Fig 1. Bolts with locking nuts are used at all linkage points, the longest bolt being used at point 'A'. Do not overtighten or the linkage will not move freely. Secure the bracket at point 'B' using the flat washer and split pin.

2.

Fig.2



Turn the bed on its back and attach the steering linkage using the bolts, flat washers and locknuts supplied as shown in fig.2. **NOTE:** Flat washers should be used against the nuts.

3.

Fig.3

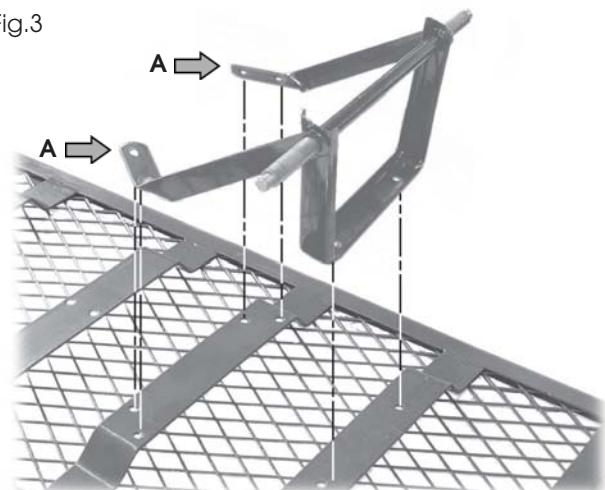

Slide the braces 'A', over the ends of the rear axle. Attach the assembly to the bed using the bolts, flat washers and locknuts supplied as shown in fig 3. **NOTE:** Flat washers should be used against the nuts.

4.

Secure the wheels using the supplied flat washers, spring washers and nuts as shown in fig. 4.



Fig.4

5.

Fig.5



Slide the handle into the trunnion and attach the assembly to the yolk on the steering assembly as shown in fig 5.

Slide the pin through the yolk and trunnion and secure with the washer and 'R' clip.

6.

Attach the fences to the bed by using the 'R' clips as shown in fig.6. If desired place the removable liner in the cart and clip to the fences.



Fig.6

PARTS & SERVICE

Replacement wheel assemblies are available from your CLARKE dealer. Please quote Part No: GT301.

CLARKE-DECE INTERNATIONAL

For spare parts and servicing, please contact your nearest dealer,
or CLARKE International on:

020 8988 7400

or email:

Parts@clarkeinternational.com

Service@clarkeinternational.com

CLARKE International, Hemnall Street, Epping, Essex, CM16 4LG