

Clarke®



ELECTRIC TILE CUTTER

Model No. ETC7 & ETC7SS

Part Nos. 3400505 & 3400510

OPERATING & MAINTENANCE INSTRUCTIONS

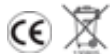

0805

Thank you for purchasing this Clarke Tile Cutting Machine.

The ETC7 tile cutter incorporates a 180mm sintered diamond cutting disk and will make straight cuts on tiles with a maximum cutting depth of 34mm.

The table may be tilted so that tiles may be cut to any angle up to 45 degrees. The maximum cutting depth at 45 degrees is 15mm.

Please read this manual thoroughly before use. This will ensure the safety of both yourself and those around you, and will also ensure long and trouble free service from your Tile Cutter.

GUARANTEE

This product is guaranteed against faults in manufacture for 12 months from purchase date. Please keep your receipt as proof of purchase.

This guarantee is invalid if the product has been abused or tampered with in any way, or not used for the purpose for which it is intended. The reason for return must be clearly stated.

This guarantee does not affect your statutory rights.

SPECIFICATIONS

Motor	230V, 50 Hz 1ph
Power Rating	400Watts
Running Current	1.9Amps
Speed	2950RPM
Fuse Rating	13 Amps
Table Dimensions	340x390mm
Weight (Net)	11.5kg
Cutting Angle	0 - 45 degrees
Cutting Depth at 90°	34mm
Cutting Depth at 45°	15mm
Cutting Disk Diameter	180mm
Cutting Disk Bore	22.2mm
Cutting Disk Part Number	6490640
Sound Power Level	104 Lw(A)
Sound Pressure Level	96dB(A)
Vibration	<2.5m/s ²
Overall Dimensions (LxWxH)	340x426x255mm
Part Number	ETC7 (Chromium plated Table) 3400505 ETC7SS (Stainless Steel Table) 3400510

GENERAL SAFETY PRECAUTIONS.

Common sense applies to the use of both this and any other electric power tool. In particular we bring the following points to your attention.

- ✓ **ALWAYS** keep the work area clean, well lit and uncluttered.
- ✓ **ALWAYS** place the machine on a firm steady base and at a comfortable working height.
- ✓ Apart from the water trough which is provided to wet the cutting disk, **ALWAYS** check to ensure that all other parts of the machine and the surrounding work area are kept dry.
- ✓ **ALWAYS** use in a well ventilated area. Never operate the saw in the presence of inflammable vapours.
- ✓ **ALWAYS** keep children well clear of the work area at all times.
- ✓ **ALWAYS** examine the cutting disk before use and replace if worn.
- ✓ **ALWAYS** allow the motor freedom, so that the cutting disk will be cutting at, or close to its maximum speed.
- ✓ **ALWAYS** use Clarke general purpose safety goggles to protect the eyes from flying particles.
- ✓ **ALWAYS** take suitable precautions in respect of loose clothing, long hair and jewellery, as these are potential hazards which could get caught up in the moving parts of this high speed machine.
- ✓ **ALWAYS** use a Clarke face mask to prevent inhalation of any dust which may be present.
- ✓ **ALWAYS** turn off the power supply before making any adjustments to the machine.
- ✓ The use of work gloves is recommended, providing these allow you to retain sufficient feel and sensitivity whilst operating the machine.
- ✗ **NEVER** force the cutting disk if it is reluctant to cut properly or tends to slow down.
- ✗ **NEVER** use this machine for cutting metal or vegetable matter. This machine for cutting stone, ceramics, marble and similar hard material **ONLY**.
- ✗ **NEVER** attempt to repair the mains cable. If it, or any part of the switch assembly becomes damaged, then it must be replaced.
- ✗ **NEVER** apply side thrust to the cutting disk. i.e. try to cut on one side of the disk only.
- ✗ **NEVER** operate this machine with the Disk Guard removed

ELECTRICAL CONNECTIONS

WARNING!

If the power cable is worn or cut, or damaged in any way, have it replaced immediately to avoid shock or fire hazard.

Connect the mains lead to a 230 volt (50Hz) domestic electrical supply via a standard 13 amp BS 1363 plug fitted with a 13 amp fuse, or a suitably fused isolator switch.

WARNING! THIS APPLIANCE MUST BE EARTHED.

IMPORTANT: The wires in the mains lead are coloured in accordance with the following code:

Green & Yellow - **Earth**
Blue - **Neutral**
Brown - **Live**

As the colours of the flexible cord of this appliance may not correspond with the coloured markings identifying terminals in your plug, proceed as follows:

- Connect GREEN & YELLOW coloured cord to plug terminal marked with a letter 'E' or Earth symbol "⏏", or coloured GREEN or GREEN & YELLOW.
- Connect BROWN coloured cord to plug terminal marked letter 'L' or coloured RED.
- Connect BLUE coloured cord to plug terminal marked letter 'N' or coloured BLACK.

We strongly recommend that this unit is connected to the mains supply via a Residual Current Device (RCD).

IMPORTANT!

If this appliance is fitted with a plug which is moulded onto the electric cable (i.e. non- re-wireable) please note:

1. The plug must be thrown away if it is cut from the electric cable. There is a danger of electric shock if it is subsequently inserted into a socket outlet.
2. Never use the plug without the fuse cover fitted.
3. Should you wish to replace a detachable fuse carrier, ensure that the correct replacement is used (as indicated by marking or colour code).
4. Replacement fuse covers can be obtained from your local dealer or most electrical stockists.

Fuse Rating

The fuse in the plug must be replaced with one of the same rating (**13 amps**) and this replacement must be ASTA approved to BS1362.

Extension Cable

If an extension lead is needed, ensure the conductors have a diameter at least equal to that of the cable fitted to the machine. Always unwind the extension cable fully before use.

INSTALLATION

Provision is made so that the Tile Cutter may be semi-permanently fixed to a workbench or table, using suitable bolts in the two slotted holes in the base of the machine.

If a permanent location is not feasible or desirable, always ensure its temporary location is flat and even and at a convenient height with adequate light.

OPERATION

1. With the machine disconnected from the mains supply, measure the tile or piece of material to be cut and proceed to adjust:
 - A. The angle of the table which can be adjusted up to 45 degrees from the horizontal for mitre edge cuts if required. For normal straight cuts at 90 degrees, the table should be set to zero degrees on the bevel scale.

NOTE:

Bevel cuts are usually made on the right side of the cutting disk, i.e. on the 'downward' slope side of the disk, so that the glazed side of the tile is uppermost, and as there is little room here for the parallel fence, this operation is usually carried out freehand. DO NOT exert side pressure on the cutting disk.

- B. The position of the fence on the table top. To ensure accurate cuts, check the alignment of the fence by reference to the built in calibrations which are set into each end of the table top.

Retighten all locking knobs securely to ensure secure positions for both the table and the fence.
2. Fill the water trough located underneath the table with just sufficient water so that the edge of the cutting disk can be kept constantly wet. Do not overfill as this can cause an unnecessary mess. Check the water level **constantly** during use and top up as necessary.
3. Start the machine by pressing the green button on the switch panel, marked 'I'.
4. Holding the material firmly at all times, against the parallel fence, or held in the mitre gauge, as required, move it steadily over the table, into the cutting edge of the disk.

DO NOT force the tile through the disk. Keep the speed of the disk as near to its maximum speed as possible..

Always cut in a straight line and **DO NOT** attempt to cut a curved line.

Keep hands well clear of the disk whilst it is in motion. Remove all pieces using a piece of wood, or similar, before making the next cut.

5. To stop the machine at any time, press the red button on the switch panel marked 'O'.

Always do this as soon as cutting has been completed, and before making any adjustments to the machine.

NOTE:

In order to get the feel of the machine and reduce the possibility of wastage, we recommend that trial cuts are made first with surplus or scrap material of a similar type to that to be cut.

CHANGING THE CUTTING DISK

1. Ensure that the machine is switched off and disconnected from the mains.
2. First remove the water trough, then remove the two screws securing the cutting disk cover, beneath the table, and withdraw the cover. Retain the plastic Splash Guard, which is secured by the same screws.
3. The drive shaft has two flats milled on its end, allowing a spanner to be used to hold the shaft whilst undoing the disk securing nut using a 19mm spanner. Pull off the Disk Flange, followed by the disk.
4. Take this opportunity to clean the drive-shaft of any foreign matter.
5. Replace the cutting disk ensuring the direction of rotation is correct. If in doubt, take note that the shaft rotates in an anticlockwise direction, as you look directly at it. The disk must be fitted so that the arrow, on the blade, points in the SAME direction.
6. Replace the disk flange and screw on the nut. It is sufficient that the nut be tightened only as much as is possible whilst holding the disk by hand. DO NOT overtighten.
7. Replace the disk cover, ensuring the plastic splash plate is in place.

IMPORTANT: The splash plate MUST be in place to avoid the possibility of water entering the motor housing.

MAINTENANCE

When carrying out servicing or maintenance tasks...ALWAYS disconnect the machine from the mains supply.

Always rotate the cutting disk by hand before use to check for cracks or distortion. If any damage is detected, renew the disk.

Check the power cable to ensure it is in perfect condition.

Drain the water tank after use and ensure it is dry before storing.

ALWAYS maintain the machine in top condition. When not in use, keep it covered, and store in a dry place, not exposed to the elements.



When disposing of this product, ensure it is disposed of according to all local ordinances

DECLARATION OF CONFORMITY

We declare that this product conforms to the following standards/directives

89/392/CEE, modified by 98/68/CEE (Machinery Directive)

93/68/CEE modified by EN61029-1 (LVD)

98/336/CEE modified by 93/68/CEE (EMC)

PARTS LIST AND DIAGRAM

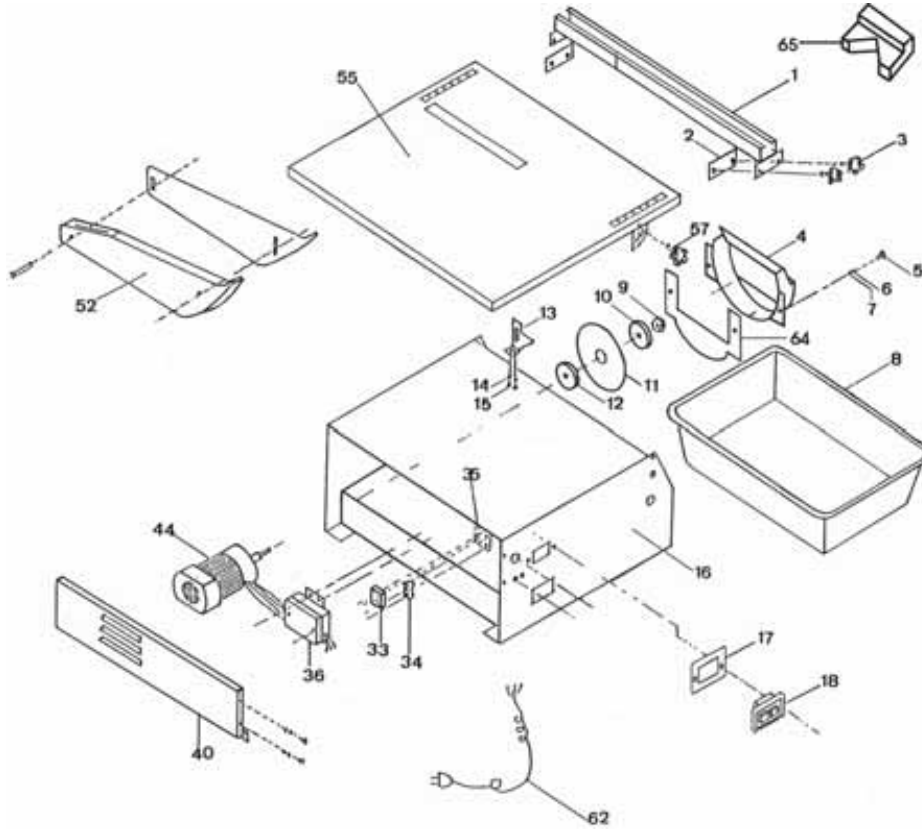

No.	Description	Part No.	No.	Description	Part No.
1	Parallel Fence	TMCETC701	16	Cabinet	TMCETC716
2	Clamp	TMCETC702	17	Switch Box Cover	TMCETC717
3	Lock Knob	TMCETC703	18	Switch Assembly	TMCETC718
4	Cutting Disk Cover	TMCETC704	33	Terminal Block	TMCETC733
5	Screw	TMCETC705	34	Cable Clamp	TMCETC734
6	Lock Washer	TMCETC706	35	Terminal Base	TMCETC735
7	Flat Washer	TMCETC707	36	Capacitor	TMCETC736
8	Water Trough	TMCETC708	40	Side Cover	TMCETC740
9	Hex. Nut M12	TMCETC709	44	Motor	TMCETC744
10	Outer Flange	TMCETC710	52	Disk Guard	TMCETC752
11	Cutting Disk	TMCETC711	55	Table STC7	TMCETC755
12	Inner Flange	TMCETC712	55	Table ETC7SS	TMCETC755A
13	Disk Guard Support	TMCETC713	57	Lock Knob	TMCETC757
14	Washer	TMCETC714	62	Power Cord	TMCETC762
15	Hex. Screw M4	TMCETC715	64	Splash Guard	TMCETC764