

A SELECTION FROM THE VAST RANGE OF

# Clarke<sup>TM</sup>

## QUALITY PRODUCTS

### AIR COMPRESSORS

From DIY to industrial. Plus air tools, spray guns and accessories.

### GENERATORS

Prime duty or emergency standby for business, home and leisure.

### POWER WASHERS

Hot and cold, electric and engine driven - we have what you need.

### WELDERS

Mig, Arc, Tig and Spot. From DIY to auto/industrial.

### METALWORKING

Drills, grinders and saws for DIY and professional use.

### WOODWORKING

Saws, sanders, lathes, mortisers and dust extraction.

### HYDRAULICS

Cranes, body repair kits, transmission jacks for all types of workshop use.

### WATER PUMPS

Submersible, electric and engine driven for DIY, agriculture and industry.

### POWER TOOLS

Angle grinders, cordless drill sets, saws and sanders.

### STARTER/CHARGERS

All sizes for car & commercial use.



# Clarke<sup>TM</sup>



## RANGER 30 & 60 AIR COMPRESSOR

## OPERATING & MAINTENANCE INSTRUCTIONS

**Clarke** INTERNATIONAL

For spare parts and servicing, please contact your nearest dealer, or Clarke International on

**020 - 8988 - 7400**

e-mail: [Parts@clarkeinternational.com](mailto:Parts@clarkeinternational.com) e-mail: [Service@clarkeinternational.com](mailto:Service@clarkeinternational.com)



## COMPRESSOR

No.	Description	Qty	Part No.	No.	Description	Qty	Part No.
1	Head Bolt	4	FN014002021	21	Bearing	1	FN033018000
2	After Cooler	1	FN116117020	22	Shaft Assy.	1	FN116032006
3	Cylinder Head	1	FN016055040	23	End Housing Gasket	1	FN116001025
4	Filter Unit	1	FN317050000	24	Dipstick	1	FN012035000
5	Head Gasket (Upper)	1	FN116117002	25	End Housing	1	FN016032014
6	Valve Block	1	FN116022100	26	Screw	1	FN014013024
7	Screw	2	FN014013021	27	Screw	5	FN014006121
8	O-Ring	1	FN010102000	28	Bolt	2	FN116011038
9	Head Gasket (Lower)	1	FN116022010	29	Motor Housing	1	FN116022051
10	Screw	2	FN014011064	30	Rotor	1	FN116032007
11	Cylinder Block	1	FN116001004	31	Stator Assy	1	FN416033604
12	O-Ring	1	FN010114000	32	Bearing	1	FN033005000
13	Piston Ring set	1	FN216022002	33	Housing	1	FN116011001
14	Piston	1	FN116022004	34	Nut	2	FN014003002
15	Gudgoen Pin	1	FN116022040	35	Fan Assy.	1	FN116001003
16	Circlip	2	FN015001000	36	Cover	1	FN116117015
17	Piston Assy compl.	1	FN416022004	37	Overload Reset	1	FN008040000
18	Con-Rod	1	FN116091021	38	Washer	1	FN010072000
19	Washer	1	FN014005006	39	Filter Element	1	FN116055043
20	Capacitor	1	FN009200015	-	Gasket Set	1	FN216HN0001

## PARTS and SERVICE CONTACTS

For Spare Parts and Service, please contact your nearest dealer,  
or CLARKE International, on one of the following numbers.

**PARTS & SERVICE TEL: 020 8988 7400**

**PARTS & SERVICE FAX: 020 8558 3622**

or e-mail as follows:

**PARTS: [Parts@clarkeinternational.com](mailto:Parts@clarkeinternational.com)**

**SERVICE: [Service@clarkeinternational.com](mailto:Service@clarkeinternational.com)**

# COMPRESSOR

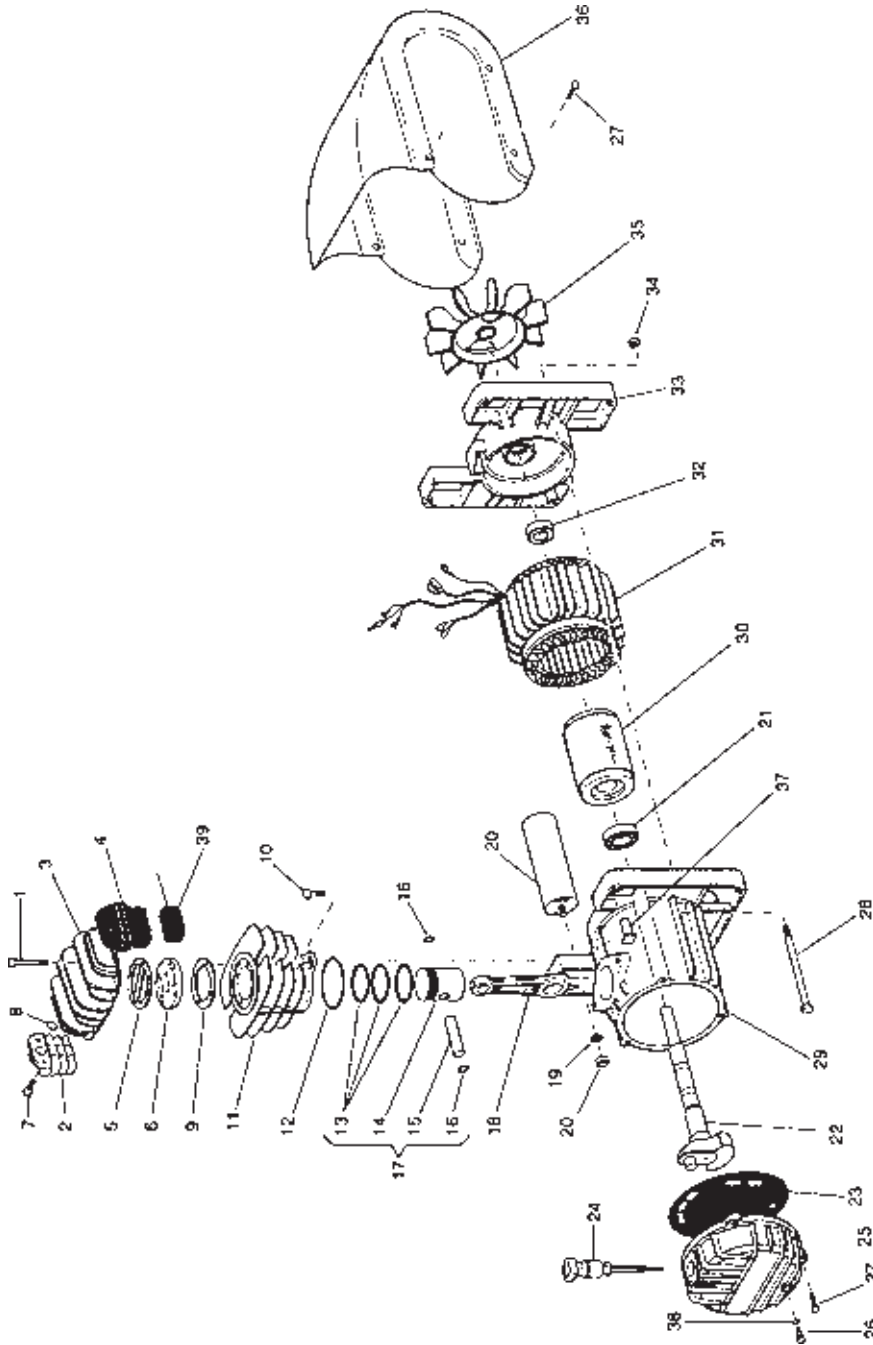

Thank you for purchasing this Ranger Air Compressor which is available in two configurations - RANGER 30, fitted with a 24 litre air receiver and RANGER 60, fitted with a 50 litre receiver.

Before attempting to operate the machine, please read this leaflet thoroughly and carefully follow the instructions given. In doing so you will ensure the safety of yourself and that of others around you, and you can also look forward to the compressor giving you long and satisfactory service.

## GUARANTEE

This product is guaranteed against faulty manufacture for a period of 12 months from the date of purchase. Please keep your receipt as proof of purchase. This guarantee is invalid if the product is found to have been abused or tampered with in any way, or not used for the purpose for which it was intended.

Faulty goods should be returned to their place of purchase, no product can be returned without prior permission. This guarantee does not effect your statutory rights.

## CONTENTS

Page

Safety Precautions .....	4
Electrical Connections .....	5
Preparation for Use .....	6
Operation .....	6
Shutting Down .....	8
Maintenance .....	8
Fault Finding .....	10
Specifications .....	11
Accessories .....	11
Parts Lists and Diagrams .....	12 - 15
Parts and Service .....	2 - 15

## SAFETY PRECAUTIONS

### WARNING

As with all machinery, there are certain hazards involved with their operation and use. Exercising respect and caution will considerably lessen the risk of personal injury. However, if normal safety precautions are overlooked, or ignored, personal injury to the operator, or damage to property may result. It is in your own interest to read and pay attention to the following rules:

- X NEVER direct a jet of air at people or animals, and NEVER discharge compressed air against the skin. **COMPRESSED AIR IS DANGEROUS,**
- X NEVER operate your compressor with any guards removed.
- X NEVER carry out electrical or mechanical repairs unless you are fully qualified. If problems occur, contact your Clarke dealer.
- X NEVER exert any strain on electrical cables and ensure that air hoses are not tangled or wrapped around machinery etc.
- X NEVER leave pressure in the receiver overnight, or when transporting.
- X NEVER adjust, or tamper with the safety valves. The maximum pressure is factory set, and clearly marked on the machine.
- X NEVER operate in wet or damp conditions. Keep the machine dry at all times. Similarly, a clean atmosphere will ensure efficient operation. Do not use in dusty or otherwise dirty locations.
- X Some of the metal parts can become quite hot during operation. NEVER touch these until the machine has cooled down.
- ✓ ALWAYS adjust the pressure regulator to the recommended setting for the particular spray gun or tool being used.
- ✓ ALWAYS ensure that there is adequate ventilation and keep clear of any possible source of ignition when spraying inflammable materials e.g. cellulose paint.
- ✓ ALWAYS protect yourself. Think carefully about any potential hazards which may be created by using the air compressor and use the appropriate protection. e.g. Goggles will protect your eyes from flying particles. Face masks will protect you against paint spray and/or fumes.
- ✓ ALWAYS consult paint manufacturers instructions for safety and usage before spraying any material always .
- ✓ ALWAYS ensure the pressure is expelled from the air receiver, and the machine is disconnected from the mains supply Before carrying out any maintenance.
- ✓ ALWAYS ensure that the air supply is turned off at the machine outlet when disconnecting air hoses or other equipment from your compressor. Expel all pressurised air from within the machine and other equipment attached to it.
- ✓ ALWAYS ensure that children and animals are kept well away from the compressor and any equipment attached to it.
- ✓ ALWAYS ensure that all individuals using the compressor have read and fully understand the Operating Instructions supplied.
- ✓ ALWAYS ensure that any equipment or tool used in conjunction with your compressor, has a safety working pressure exceeding that of the machine.

## RANGER 60

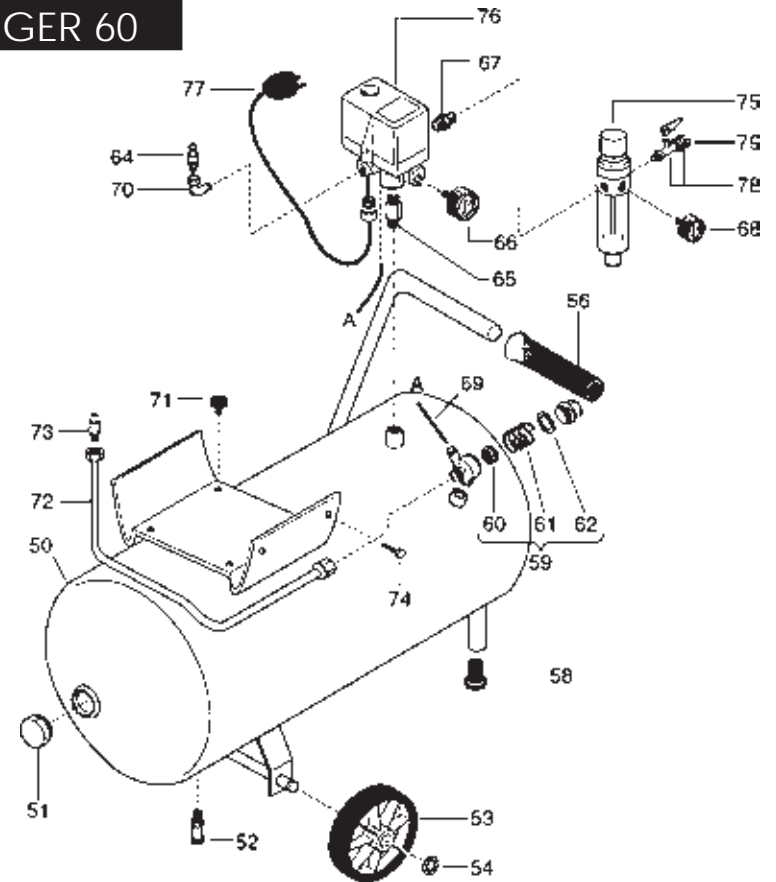

No.	Description	Qty	Part No.	No.	Description	Qty	Part No.
50	Reservoir	1	FN17005400V	67	Adapter	1	FN011017000
51	End Plug	2	FN011008000	68	Pressure Gauge-Line	1	FN330006000
52	Drain valve	1	FN022020000	69	Tube	-	FN046001000
53	Wheel	2	FN020001000	70	Elbow	1	FN011002000
54	Push on Fasteners	2	FN015029000	71	Anti-vibration pads	1	FN199575000
56	Hand Grip	1	FN020121000	72	Steel Tube	4	FN170HN0010
58	Rubber Foot	1	FN020093000	73	Adapter	1	FN011248000
59	Valve Assembly	1	FN347043000	74	Screw	4	FN014013042
60	Valve	1	FN047113001	75	Regulator Assy w/filter	1	FN319042000
61	Spring	1	FN047113002	76	Pressure Reg. Assy	1	FN321028000
62	Washer	1	FN010041000	77	Mains Lead w/plug	1	N101GA0200
64	Valve	1	FN347027000	78	Tap Assy	1	FN322008000
65	Adapter	1	FN199110140	79	Quick Release Conn.	1	FN116011065
66	Pressure Gauge-Res	1	FN330007000				

## RANGER 30

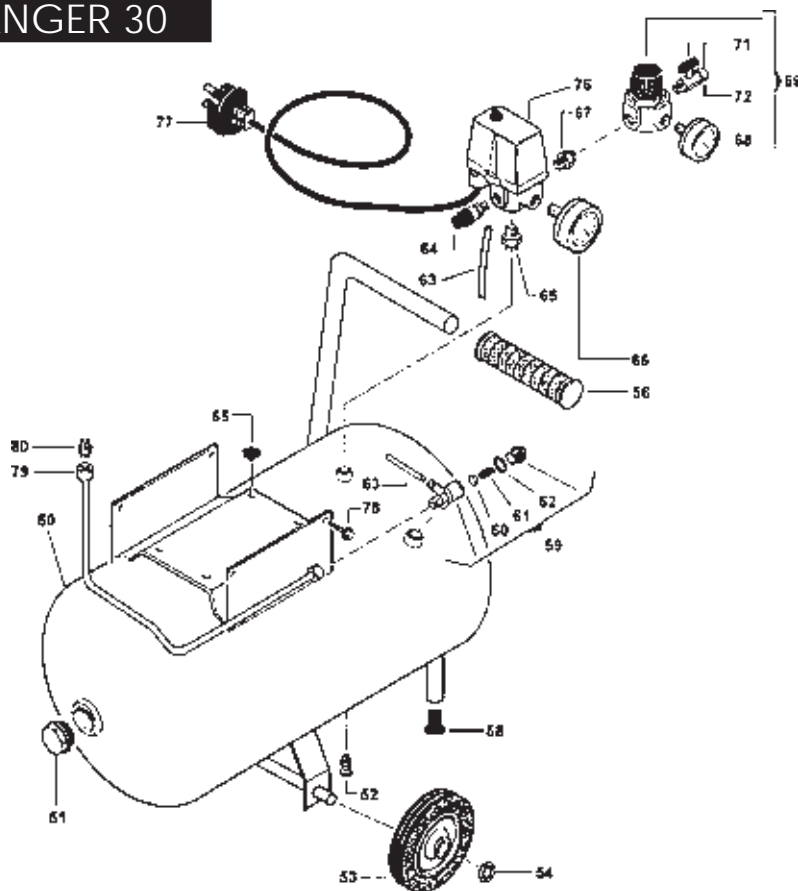

No.	Description	Qty	Part No.	No.	Description	Qty	Part No.
50	Reservoir	1	N168H96000V	64	Valve	1	FN347022000
51	End Plug	2	FN011008000	65	Adapter	1	FN199110140
52	Drain valve	1	FN022020000	66	Pressure Gauge-Res	1	FN330004000
53	Wheel	2	FN020130000	67	Adapter	1	FN011017000
54	Push on Fasteners	2	FN015024000	68	Pressure Gauge-Line	1	FN330006000
55	Anti-vibration pads	4	FN199575000	69	Output Reg. Assy	1	FN319013000
56	Hand Grip	1	FN010121000	71	Tap Assy	1	FN322007000
58	Rubber Foot	1	FN020118000	72	Quick Release Conn.	1	FN116011065
59	Valve Assembly	1	FN347043000	76	Pressure Reg. Assy	1	FN321053000
60	Valve	1	FN047113001	77	Mains Lead w/plug	1	FN101GA0200
61	Spring	1	FN047113002	78	Screw	1	FN014013042
62	Washer	1	FN010041000	79	Steel Tube	4	FN117HN0001
63	Tube	-	FN046001000	80	Adapter	1	FN011248000

## ELECTRICAL CONNECTIONS

Connect the mains lead to a standard, 230 Volt (50Hz) electrical supply through an approved 13 amp BS 1363 plug, or a suitably fused isolator switch.

### WARNING! THIS APPLIANCE MUST BE EARTHED

**IMPORTANT:** The wires in the mains lead are coloured in accordance with the following code:

Green & Yellow	-	Earth
Blue	-	Neutral
Brown	-	Live

As the colours of the flexible lead of this appliance may not correspond with the coloured markings identifying terminals in your plug proceed as follows:

- Connect GREEN & YELLOW cord to terminal marked with a letter "E" or Earth symbol "⏏" or coloured GREEN or GREEN & YELLOW.
- Connect BROWN cord to terminal marked with a letter "L" or coloured RED.
- Connect BLUE cord to terminal marked with a letter "N" or coloured BLACK.

If this appliance is fitted with a plug which is moulded onto the electric cable (i.e. non-rewireable) please note:

1. The plug must be thrown away if it is cut from the electric cable. There is a danger of electric shock if it is subsequently inserted into a socket outlet.
2. Never use the plug without the fuse cover fitted.
3. Should you wish to replace a detachable fuse carrier, ensure that the correct replacement is used (as indicated by marking or colour code).
4. Replacement fuse covers can be obtained from your local dealer or most electrical stockists.

### FUSE RATING

The fuse in the plug must be replaced with one of the same rating (**13 amps**) and this replacement must be approved to BS1362.

**We recommend that this machine is connected to the mains supply via a Residual Current Device (RCD)**

If in any doubt, DO NOT attempt any connections or repairs yourself. Consult a qualified electrician, or your local Clarke international dealer.

## PREPARATION FOR USE

**NOTE:** All numbered items throughout this manual refer to the parts list item number on Pages 12 - 15

1. Remove the plastic travel plug from the oil filler hole, on the top of the crank case, and insert the dipstick (see Fig. 7 - page 9).
2. Check the oil level is at the correct level on the dipstick, as shown in Fig.1. Where necessary, top up with Clarke international Compressor Oil (Available from your local Clarke international superstore).
3. Remove plastic travel plug from air filter inlet and screw on air filter using the single screw provided.

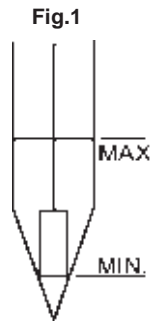

## OPERATION (Ref. Fig. 2)

**NOTE:** If you intend using your compressor for spraying, read also the 'Helpful Hints on Spraying' booklet - supplied with the machine.

1. Check that the mains voltage corresponds with that shown on the data sticker on the crankcase cover of the machine.
2. Ensure that the ON/OFF switch is in the 'OFF' (0) position, i.e. pushed DOWN, then plug in and switch on at the mains supply.
3. To start the compressor pull UP the ON/OFF switch to the 'ON' (I) position - the motor should start immediately.

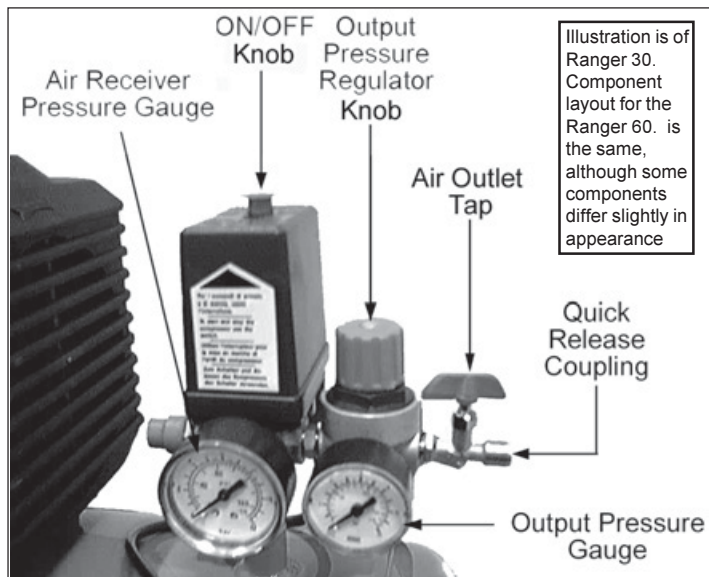

## SPECIFICATIONS

Rotational Speed .....	2850 rpm
Max. Pressure .....	10 bar
Air Displacement .....	7 cu ft/min
Electric Motor .....	1½ hp (1.1kW)
Receiver .....	Ranger 30 ..... 24 Ltr
	Ranger 60 ..... 50 LTR
Cylinder Head Bolt Torque Setting .....	8.8Nm
Fuse Rating .....	13amps
Duty Cycle .....	S1 at max. 7 bar
	(i.e. Compressor may run continuously at 7 bar max.)

Please note that the details and specifications contained herein, are correct at the time of going to print. However, CLARKE INTERNATIONAL reserve the right to change specifications at any time without prior notice. Always consult the machines Data Plate

## ACCESSORIES

Your Ranger Air Compressor can be used in conjunction with a range of optional accessories for inflating tyres, air brushing, stapling, blowing and many other uses. For details contact your local dealer.

A complete kit is available which is ideal for almost all applications (see below).

Please quote **KIT400....part number 3110165**



Also available without the spray Gun - **Part No. 3110170**

- or items sold separately

Should you experience any difficulties obtaining accessories, please contact Clarke international by telephoning 01992 565300 for details of your nearest Clarke international dealer

## FAULT FINDING

PROBLEM	PROBABLE CAUSE	REMEDY
The compressor stops and will not start again.	Bad connections.  Blown fuse Overload cutout switch has tripped.	Check the electrical connections. Clean and tighten as necessary. Renew/Replace fuse Switch off and wait 5 minutes before pressing the reset button.
The compressor does not reach the set pressure and overheats easily.	Compressor head gasket blown or valve broken.	Wait for compressor to cool down, disassemble the head and replace any broken components. Carefully clean all sealing surfaces before reassembling. If in doubt contact Clarke international  <i>NOTE: It is also possible that you are using more air than the compressor is capable of delivering.</i>
Compressor does not start.	Air receiver charged (see also item 1)	Open drain cock to expel air. Compressor should start again when pressure reduces to approx 95 psi.
Air leaking from the pressure switch valve when the compressor is not running.	Faulty non-return valve.	First drain the receiver completely of air. Remove the valve end plug, carefully clean the valve seat and the gasket and reassemble. See Fig 8.
Air pressure from the regulator will not adjust.	The diaphragm within the regulator body is broken.	Replace Regulator
The compressor is very noisy and makes a metallic knocking sound.	Compressor damaged and needs overhaul.	Return the machine to Clarke international.

**NOTE:** Should the motor fail to start immediately, it is probable that the air receiver is already full of air. Check the tank pressure gauge (see fig. 2). If you release air, by opening air outlet tap, the motor will start automatically once the cut-in pressure is reached.

- Before connecting your airline to the compressor allow it to run with the air outlet tap completely open for 10 - 15 seconds to permit a good distribution of the lubricating oil.
- Close the outlet tap then connect one end of suitable air hose to the compressor air outlet, and the other end to the equipment to be used.  
  
Set the outlet pressure by adjusting the Output Pressure Regulator. To do this, turn the knob clockwise to increase pressure, anti-clockwise to decrease.  
  
The Ranger 60 requires that the Regulator Knob be pulled upwards before it may be turned. Pushing the knob down again holds the pressure setting. Read the operating pressure on the outlet pressure gauge.

**NOTE:** For most spraywork do not exceed 50 psi (unless following paint manufacturers instructions).

For other airline equipment such as air tools, tyre gauges, staple guns, paraffin guns etc., it may be necessary to set the operating pressure at a higher (or lower) level.

**IMPORTANT:** Always refer to the accessory manufacturers' recommendations for optimum operating pressures for their equipment.

- With operating pressure set, reopen the air outlet tap.
- The Pressure Switch, located within the plastic cover beneath the ON/OFF switch, should not require adjustment. This is an automatic device and has been preset at the factory to stop the motor when pressure in the receiver reaches its maximum, and to start it again when the pressure falls to the minimum preset value. This operation is completely automatic and does not affect the spraying process in any way. However, should problems develop with the cut-in, cut out settings, consult your local Clarke international Service Dep't.

**NOTE:**

- If the machine pumps continuously without cutting out then the compressor is too small for the application/tool being used, and damage may result. Consult your local Clarke international outlet.
- The motor is protected by a Thermal Overload so that if the motor overheats for any reason -the thermal overload will trip, stopping the motor. To restart, allow a period for the motor to cool down (5 min), before pressing the Reset Button, illustrated in fig. 3.
- DO NOT exceed the Duty Cycle for the machine (see Specifications)

Fig. 3

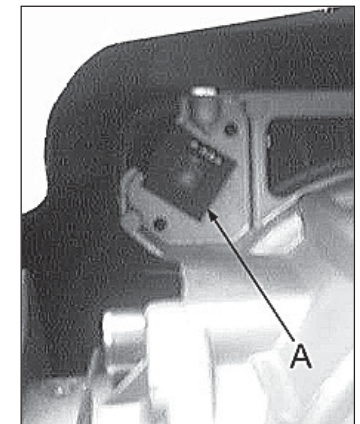

## SHUTTING DOWN THE COMPRESSOR

1. The Pressure Switch is provided with an ON/OFF switch (See Fig. 2) which, when pushed down to the 'OFF' (0) position, cuts off the motor. Always use this switch to shut down the compressor. **NEVER USE THE MAINS SWITCH TO STOP MOTOR.**
2. Close the air outlet tap and trigger the equipment (spraygun, air tool etc) to release air from the air hose before disconnecting the hose from the machine.
3. Before transporting your compressor or when leaving overnight, expel all air from the receiver by opening drain valve (52).

**Note:** The Ranger 60 incorporates a Regulator/Filter which automatically allows any condensate to drain off when pressure in the reservoir is completely relieved. Water may also be drained off when the system is under pressure. The method of operation is shown in Fig 4.

Turn the knob, at the base of the filter bowl, to the right to lock it, to the left to unlock.

In the 'unlocked' position, condensate will automatically drain when the pressure in the system is near zero.

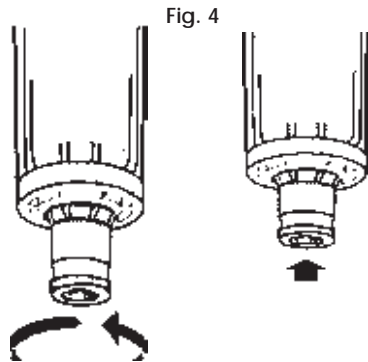

To blow off condensate when the system is pressurised, push the knob up when it is in its unlocked position.

## MAINTENANCE

### A. DAILY

1. Check the oil level before you start and top-up if necessary - (use Clarke International compressor oil).
2. Drain any condensate that may have accumulated in the receiver by unscrewing the drain plug underneath the air receiver (fig. 5).

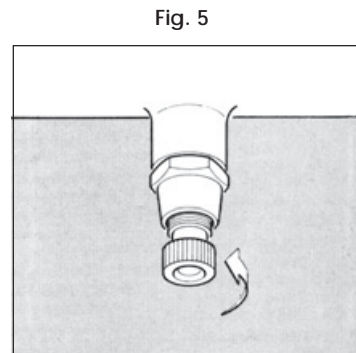

### B. PERIODICALLY

1. After the first 5 hours of running the compressor, check the cylinder head

bolts and motor housing screws and if any have worked loose retighten to 8.8Nm max.,

2. Every 50 hours (more frequently if used in a dusty environment), clean the air intake filter, by carefully prising the filter from the head, opening the bottom flap and withdrawing the sponge element from inside (see fig 6).

Clean the sponge and the inner housing. If necessary, the sponge filter may be gently washed in warm soapy water, rinsed and allowed to dry thoroughly before refitting.

If any part of the filter is damaged then you should obtain a replacement.

3. After the first 100 hours use, replace the oil completely using Clarke international compressor oil. Thereafter, replace the oil completely after every 500 hours of operation or every 6 months.

To empty the oil from the machine, remove the drain plug from the crankcase cover (see fig. 7).

4. Every 500 hours of operation or every 6 months
  - clean all the external parts of the compressor.

*(This cleaning makes the cooling process more efficient and prolongs the life of the machine).*

- Check and clean the inlet and outlet valves
- Examine the non-return valve and replace the gasket if necessary (fig. 8)

5. In the event of an air leak follow the procedure below:

- Load compressor to maximum pressure
- Unplug the compressor
- With a brush and soapy water wet all 'screwed' air connections
- Any leaks will show through the formation of air bubbles.

Fig. 6

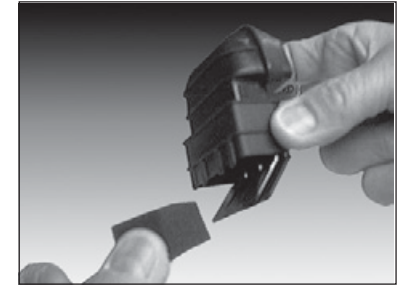

Dipstick

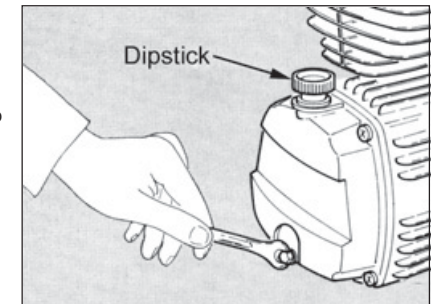
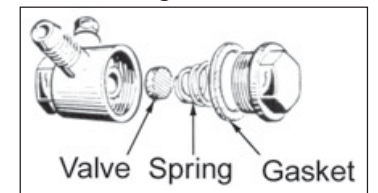

Fig. 7

Fig. 8



Parts List item No. 59

### WARNING

**NEVER UNSCREW A CONNECTION WHILST THE AIR RECEIVER IS UNDER PRESSURE. ALWAYS MAKE CERTAIN THAT THE TANK HAS FIRST BEEN EMPTIED**