

A SELECTION FROM THE VAST RANGE OF

ClarkeTM

QUALITY PRODUCTS

AIR COMPRESSORS

From DIY to industrial. Plus air tools, spray guns and accessories.

GENERATORS

Prime duty or emergency standby for business, home and leisure.

POWER WASHERS

Hot and cold, electric and engine driven - we have what you need.

WELDERS

Mig, Arc, Tig and Spot. From DIY to auto/industrial.

METALWORKING

Drills, grinders and saws for DIY and professional use.

WOODWORKING

Saws, sanders, lathes, mortisers and dust extraction.

HYDRAULICS

Cranes, body repair kits, transmission jacks for all types of workshop use.

WATER PUMPS

Submersible, electric and engine driven for DIY, agriculture and industry.

POWER TOOLS

Angle grinders, cordless drill sets, saws and sanders.

STARTER/CHARGERS

All sizes for car & commercial use.



ClarkeTM air



RAIDER 60 / 120

OPERATION & MAINTENANCE INSTRUCTIONS

Clarke INTERNATIONAL

For spare parts and servicing, please contact your nearest dealer, or Clarke International on

020 - 8988 - 7400

e-mail: Parts@clarkeinternational.com e-mail: Service@clarkeinternational.com

NOTES

SPARE PARTS AND SERVICE

Please contact your nearest dealer, or
CLARKE International, on one of the following numbers.

PARTS & SERVICE TEL: 020 8988 7400

PARTS & SERVICE FAX: 020 8558 3622

or e-mail as follows:

PARTS: Parts@clarkeinternational.com

SERVICE: Service@clarkeinternational.com

Thank you for purchasing this Raider Air Compressor.

Before attempting to operate the machine, please read this leaflet thoroughly and carefully follow the instructions given. In doing so you will ensure the safety of yourself and that of others around you, and you can also look forward to the compressor giving you long and satisfactory service.

GUARANTEE

This product is guaranteed against faulty manufacture for a period of 12 months from the date of purchase. Please keep your receipt as proof of purchase. This guarantee is invalid if the product is found to have been abused or tampered with in any way, or not used for the purpose for which it was intended. Faulty goods should be returned to their place of purchase, no product can be returned without prior permission. This guarantee does not effect your statutory rights.

CONTENTS

Page

Safety Precautions	4
Electrical Connections	5
Preparation for Use	5
Operation	6
Shutting Down	8
Maintenance	8
Fault Finding	10
Specifications	11
Accessories	11
Parts Description and Spare Parts	12 & 13
Parts & Service contacts	14

SAFETY PRECAUTIONS

WARNING

As with all machinery, there are certain hazards involved with their operation and use. Exercising respect and caution will considerably lessen the risk of personal injury. However, if normal safety precautions are overlooked, or ignored, personal injury to the operator, or damage to property may result. It is in your own interest to read and pay attention to the following rules:

1. COMPRESSED AIR IS DANGEROUS, NEVER direct a jet of air at people or animals, and NEVER discharge compressed air against the skin.
2. DO NOT operate your compressor with any guards removed.
3. Electrical or mechanical repairs should only be carried out by a qualified engineer. If problems occur, contact your Clarke dealer.
4. Before carrying out any maintenance, ensure the pressure is expelled from the air receiver, and the machine is disconnected from the mains supply.
5. DO NOT leave pressure in the receiver overnight, or when transporting.
6. DO NOT adjust, or tamper with the safety valves. The maximum pressure is factory set, and clearly marked on the machine.
7. DO NOT operate in wet or damp conditions. Keep the machine dry at all times. Similarly, a clean atmosphere will ensure efficient operation. Do not use in dusty or otherwise dirty locations.
8. Some of the metal parts can become quite hot during operation. Take care not to touch these until the machine has cooled down.
9. Always adjust the pressure regulator to the recommended setting for the particular spray gun or tool being used.
10. When spraying inflammable materials e.g. cellulose paint, ensure that there is adequate ventilation and keep clear of any possible source of ignition.
11. Protect yourself. Think carefully about any potential hazards which may be created by using the air compressor and use the appropriate protection. e.g. Goggles will protect your eyes from flying particles. Face masks will protect you against paint spray and/or fumes.
12. Before spraying any material always consult paint manufacturers instructions for safety and usage.
13. Do not exert any strain on electrical cables and ensure that air hoses are not tangled or wrapped around machinery etc.
14. When disconnecting air hoses or other equipment from your compressor ensure that the air supply is turned off at the machine outlet and expel all pressurised air from within the machine and other equipment attached to it.
15. Make sure that children and animals are kept well away from the compressor and any equipment attached to it.
16. Always ensure that all individuals using the compressor have read and fully understand the Operating Instructions supplied.
17. Ensure that any equipment or tool used in conjunction with your compressor, has a safety working pressure exceeding that of the machine.

PARTS DESCRIPTION - Raider 120

SPARE PARTS

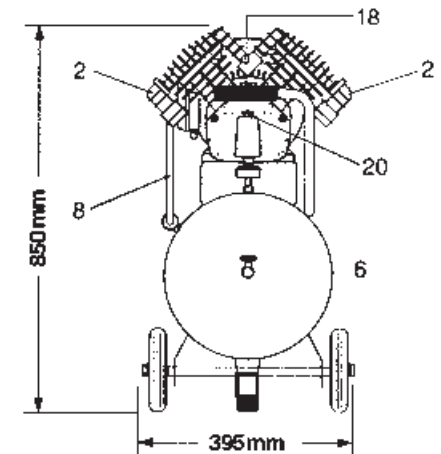
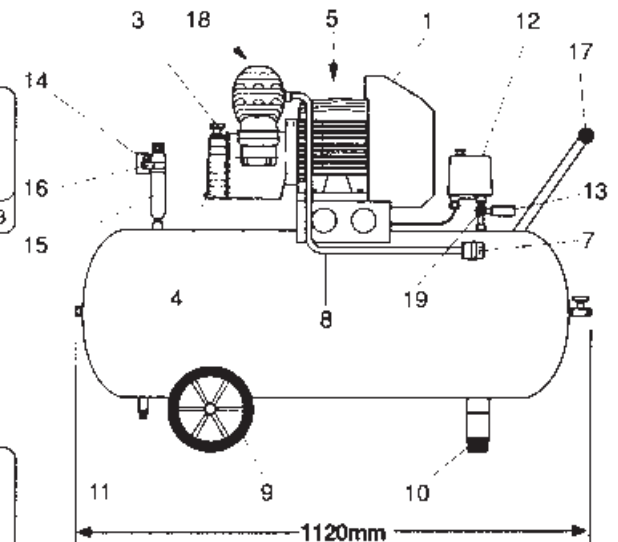
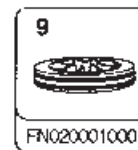
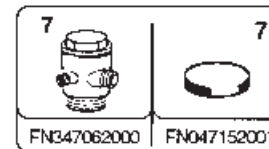
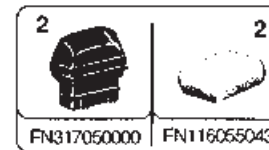

- | | |
|-----|------------------------|
| 1. | Compressor |
| 2. | Air Inlet Filter |
| 3. | Dipstick |
| 4. | Oil Drain PLUG |
| 5. | Thermal Overload Reset |
| 6. | Air Outlet Valve |
| 7. | Non-Return Valve |
| 8. | Delivery Pipe |
| 9. | Wheels |
| 10. | Vibration Damper |

- | | |
|-----|------------------------|
| 11. | Drain Valve |
| 12. | Air Pressure Switch |
| 13. | Tank Pressure Gauge |
| 14. | Outlet Pressure gauge |
| 15. | Pressure Reducer |
| 16. | Air Outlet |
| 17. | Handle |
| 18. | Low Load Startup Valve |
| 19. | Safety Valve |
| 20. | ON / OFF Switch |

PARTS DESCRIPTION - Raider 60

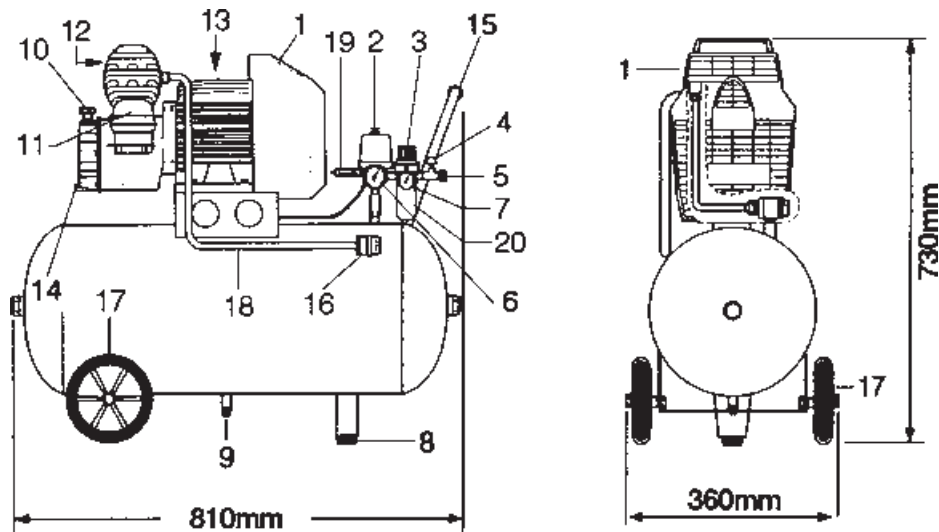

SPARE PARTS



- | | | | |
|-----|-----------------------------|-----|------------------------|
| 1. | Compressor | 11. | Air Inlet Filter |
| 2. | ON /OFF Switch | 12. | Low Load Startup Valve |
| 3. | Pressure / Regulator Knob | 13. | Thermal Overload Reset |
| 4. | Air Outlet Tap | 14. | Oil Drain |
| 5. | Air Outlet (Q/Fit Coupling) | 15. | Handle |
| 6. | Tank Pressure Gauge | 16. | Non-Return Valve |
| 7. | Outlet Pressure Gauge | 17. | Wheels |
| 8. | Vibration Damper | 18. | Delivery Pipe |
| 9. | Drain Valve | 19. | Safety Valve |
| 10. | Dipstick | 20. | Air Filter Bowl |

ELECTRICAL CONNECTIONS

Connect the mains lead to a 230 Volt (50Hz) single phase 30 amp electrical supply, through a suitably fused isolator with a fuse rating of 20 Amps.

DO NOT connect to a domestic system via a 13 AMP plug.

WARNING! THIS APPLIANCE MUST BE EARTHED

IMPORTANT: The wires in the mains lead are coloured in accordance with the following code: Green & Yellow - Earth

Blue - Neutral

Brown - Live

As the colours of the flexible lead of this appliance may not correspond with the coloured markings identifying terminals in your plug proceed as follows:

Connect GREEN & YELLOW cord to terminal marked with a letter "E" or Earth symbol $\frac{\text{E}}{\text{⏏}}$ or coloured GREEN or GREEN & YELLOW.

Connect BROWN cord to terminal marked with a letter "L" or coloured RED.

Connect BLUE cord to terminal marked with a letter "N" or coloured BLACK.

We recommend that this machine is connected to the mains supply via a Residual Current Device (RCD)

If in any doubt, DO NOT attempt any connections or repairs yourself. Consult a qualified electrician, your local Clarke dealer or Clarke International on:

020 8988 7400 or e-mail Service@clarkeinternational.com

PREPARATION FOR USE

NOTE: A plastic bag contains all loose parts.

- Slide a wheel on to each axle and secure using the push on fasteners provided. Use a suitable piece of tube or an old socket to tap the fasteners in place.
- Attach the Vibration Damper in the manner shown on the bag containing the loose parts.
- Prise off the plastic travel plug from the oil filler hole, on the top of the crank case, and insert the dipstick (see Fig. 6 - p.8).
- Check the oil level is at the correct level on the dipstick, as shown in Fig.1. Where necessary, top up with Clarke SAE40 Compressor Oil (see your Clarke dealer).

Fig.1

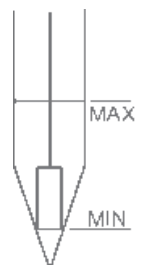

OPERATION (Ref. Fig. 2)

NOTE: If you intend using your compressor for spraying, read also the 'Helpful Hints on Spraying' booklet - supplied with the machine.

RAIDER 60

Fig. 2

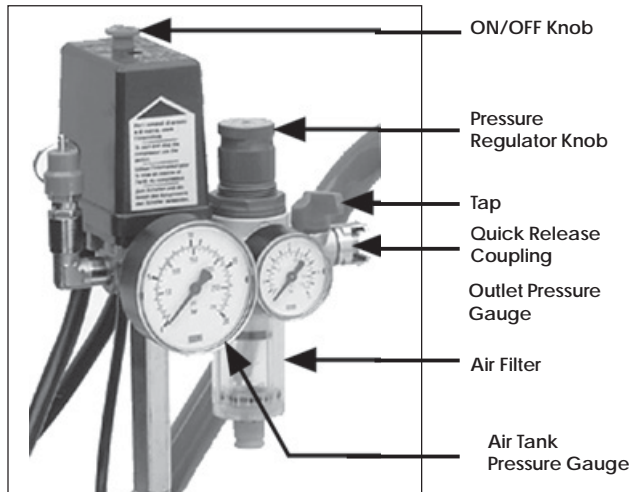

RAIDER 120

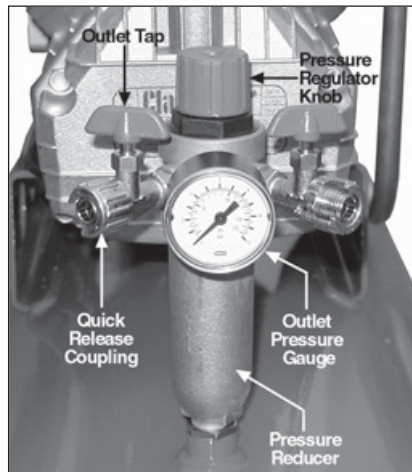
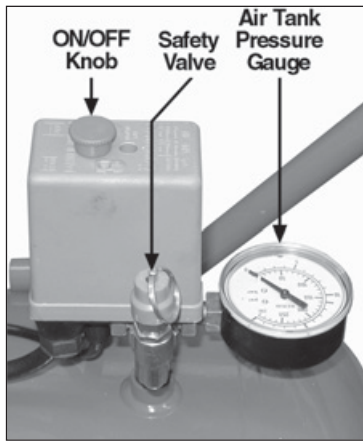

1. Check that the mains voltage corresponds with that shown on the data sticker on the crankcase cover of the machine.
2. Ensure that the ON/OFF knob is in the 'OFF' (0) position, i.e. pushed DOWN, then plug in and switch on at the mains supply.
3. To start the compressor pull UP the ON/OFF knob to the 'ON' (I) position - the motor should start immediately.

IMPORTANT: When running for the first time....allow the motor to run for a full 10 minutes, with the drain valve fully open.

SPECIFICATIONS

Rotational Speed	2850 rpm
Max. Pressure	10 bar (145psi)
Air Displacement	400L/min (14 cfm approx)
Electric Motor	3HP
Nominal Rating	13.5 Amps
Receiver	Raider 60 50 Ltr
	Raider 120 100Ltr
Compressor Oil	CLARKE SAE 40
Fuse Rating	20 amps
Part No.	Raider 60 2320600
	Raider 120 2320610
Duty Cycle	S1

(This machine may be run continuously)

Please note that the details and specifications contained herein, are correct at the time of going to print. However, CLARKE INTERNATIONAL reserve the right to change specifications at any time without prior notice. Always consult the machines' data plate,

ACCESSORIES

Your Clarke Raider Air Compressor can be used in conjunction with a range of optional accessories for inflating tyres, air brushing, stapling, blowing and many other uses. For details contact your local accessory stockist. Kits are available from your Clarke dealer which are ideal for almost all applications.

Illustrated - KIT 1000, Part Number 3110155



Should you experience any difficulties obtaining accessories, please contact the Clarke sales department (telephone 01992 565300) for details of your nearest dealer.

FAULT FINDING

PROBLEM	PROBABLE CAUSE	REMEDY
The compressor stops and will not start again.	Bad connections. Blown fuse Overload cutout switch has tripped.	Check the electrical connections. Clean and tighten as necessary. Renew/Replace fuse Switch off and wait 10 minutes before pressing the reset button.
The compressor does not reach the set pressure and overheats easily.	Compressor head gasket blown or valve broken.	Wait for compressor to cool down, disassemble the head and replace any broken components. Carefully clean all sealing surfaces before reassembling. If in doubt contact your nearest dealer. NOTE: It is also possible that you are using more air than the compressor is capable of delivering.
Compressor does not start.	Air receiver charged (see also item 1)	Open drain cock to expel air. Compressor should start again when pressure reduces to approx 95 psi.
Air leaking from the pressure switch valve when the compressor is not running.	Faulty non-return valve.	First drain the receiver completely of air. Remove the valve end plug, carefully clean the valve seat and the gasket and reassemble. See Fig 8.
Air pressure from the regulator will not adjust.	The diaphragm within the regulator body is broken.	Replace Regulator
The compressor is very noisy and makes a metallic knocking sound.	Compressor damaged and needs overhaul.	Return the machine to your nearest service agent.

NOTE:

- a. Should the motor fail to start immediately, it is probable that the air receiver is already full of air. Check the tank pressure gauge (see fig. 2). If you release air, by opening air outlet tap, the motor will start automatically once the cut-in pressure is reached.
- b. The compressor is fitted with a pressure relief valve, shown at A, fig 2A, to allow 'no load' starting. It is normal for this valve to vent air for a short period when starting.

Fig. 2A

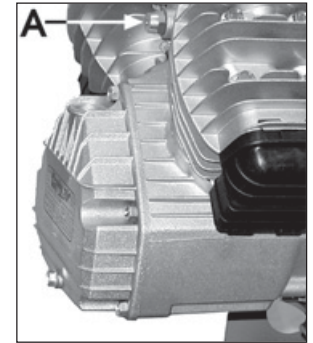

4. Before connecting your airline to the compressor allow it to run with the air outlet tap completely open for 15 to 20 seconds, to permit a good distribution of the lubricating oil.
5. Close the outlet tap then connect one end of suitable air hose to the compressor air outlet, and the other end to the equipment to be used.
Set the outlet pressure by adjusting the Output Pressure Regulator. To do this, pull the Regulator Knob upwards and turn the knob clockwise to increase pressure, anticlockwise to decrease. Pushing the knob down again holds the pressure setting. Read the operating pressure on the outlet pressure gauge.

NOTE:

For most spray work do not exceed 50 psi (unless following paint manufacturer's instructions). For other airline equipment such as air tools, tyre gauges, staple guns, paraffin guns etc., it may be necessary to set the operating pressure at a higher (or lower) level.

IMPORTANT: Always refer to the accessory manufacturers' recommendations for optimum operating pressures for their equipment.

6. With operating pressure set, reopen the air outlet tap.
7. The Pressure Switch, located within the plastic cover beneath the ON/OFF knob, should not require adjustment. This is an automatic device and has been preset at the factory to stop the motor when pressure in the receiver reaches its maximum, and to start it again when the pressure in the receiver falls to the minimum preset value. This operation is completely automatic and does not affect the spraying process in any way. However, should problems develop with the cut-in, cut out settings, please consult your Clarke dealer, or the Clarke Service Dep't.

NOTE:

- A. If the machine pumps continuously without cutting out then the compressor is too small for the application/tool being used, and damage may result. Consult your Clarke dealer.
- B. The motor is protected by a Thermal Overload so that if the motor overheats for any reason - the thermal overload will trip, stopping the motor. To restart, allow a period for the motor to cool down - 10 minutes or so, before pressing the Reset Button (arrowed in fig.3).

Fig. 3

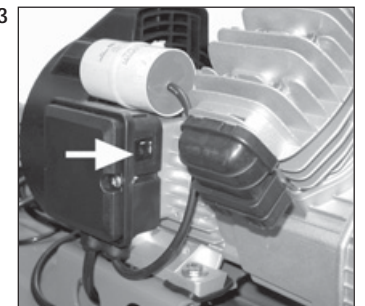

SHUTTING DOWN THE COMPRESSOR

1. To shut off the compressor, simply press **DOWN** on the ON/OFF knob (See Fig. 2). Always use this knob to shut down the compressor. **NEVER USE THE MAINS SWITCH TO STOP MOTOR.**
2. Close the air outlet tap and trigger the equipment (spraygun, air tool etc) to release air from the air hose before disconnecting the hose from the machine.
3. Before transporting your compressor or when leaving overnight, expel all air from the receiver by opening drain valve (Fig.4).

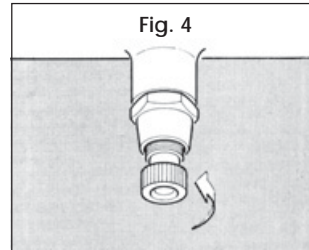

NOTE:

The Raider 60 incorporates a Regulator/Filter which automatically allows any condensate to drain off when pressure in the reservoir is completely relieved. Water may also be drained off when the system is under pressure. The method of operation is shown in fig.5

Turn the knob, at the base of the filter bowl, to the right to lock it, to the left to unlock.

In the 'unlocked' position, condensate will automatically drain when the pressure in the system is near zero.

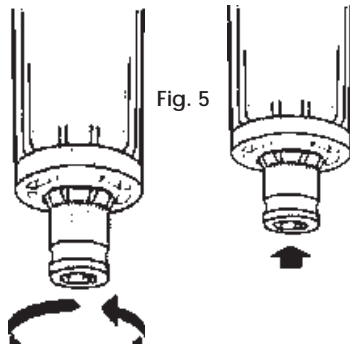

To blow off condensate when the system is pressurised, push the knob up when it is in its unlocked position.

MAINTENANCE

A. DAILY

1. Check the oil level before you start and top-up if necessary - (use Clarke SAE 40 compressor oil available from your local dealer).
2. Drain any condensate that may have accumulated in the receiver by unscrewing the drain valve underneath the air receiver (fig. 4).

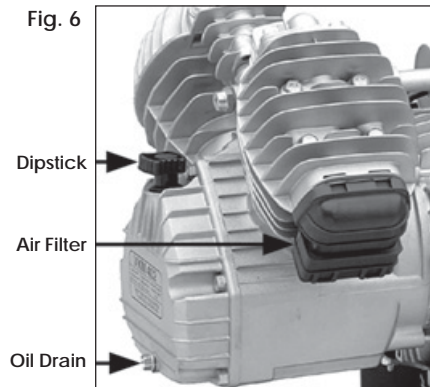

B. PERIODICALLY

1. **After the first 5 hours** of running the compressor, check the cylinder head bolts and motor housing screws and re-tighten if any have worked loose.
2. **Every 50 hours** (more frequently if used in a dusty environment), clean the air intake filters, by carefully prising each filter from its head, opening the bottom flap and withdrawing the sponge element from inside (see fig 7).

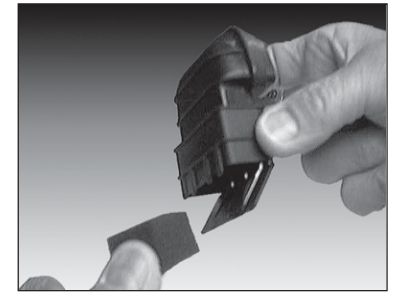

Fig. 7

Clean the sponge and the inner housing. If necessary, the sponge filter may be gently washed in warm soapy water, rinsed and allowed to dry thoroughly before refitting.

If any part of the filter is damaged then you should obtain a replacement.

3. **After the first 100 hours** use, replace the oil completely using Clarke SAE 40 compressor oil. Thereafter, replace the oil completely after every 500 hours of operation or every 6 months.

To empty the oil from the machine, remove the drain plug from the crankcase cover (shown in fig. 6).

4. **Every 500 hours** of operation **or every 6 months:**

- Clean all the external parts of the compressor. (This cleaning makes the cooling process more efficient and prolongs the life of the machine).
- Check and clean the inlet and outlet valves
- Examine the non-return valve (see Parts Description, pages 12 & 13), and replace the gasket if necessary (fig. 8)

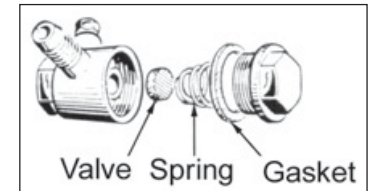

Fig. 8

5. In the event of an air leak follow the procedure below:
 - Load compressor to maximum pressure
 - Unplug the compressor
 - With a brush and soapy water wet all 'screwed' air connections
 - Any leaks will show through the formation of air bubbles.

WARNING

NEVER UNSCREW A CONNECTION WHILST THE AIR RECEIVER IS UNDER PRESSURE. ALWAYS MAKE CERTAIN THAT THE TANK HAS FIRST BEEN EMPTIED.