

A SELECTION FROM THE VAST RANGE OF

ClarkeTM

QUALITY PRODUCTS



AIR COMPRESSORS
From DIY to industrial. Plus air tools,
spray guns and accessories.

GENERATORS
Prime duty or emergency standby
for business, home and leisure.

POWER WASHERS
Hot and cold, electric and engine
driven - we have what you need.

WELDERS
Mig, Arc, Tig and Spot. From DIY to
auto/industrial.

METALWORKING
Drills, grinders and saws for DIY and
professional use.

WOODWORKING
Saws, sanders, lathes, mortisers
and dust extraction.

HYDRAULICS
Cranes, body repair kits,
transmission jacks for all types of
workshop use.

WATER PUMPS
Submersible, electric and engine
driven for DIY, agriculture and
industry.

POWER TOOLS
Angle grinders, cordless drill sets,
saws and sanders.

STARTER/CHARGERS
All sizes for car & commercial use.

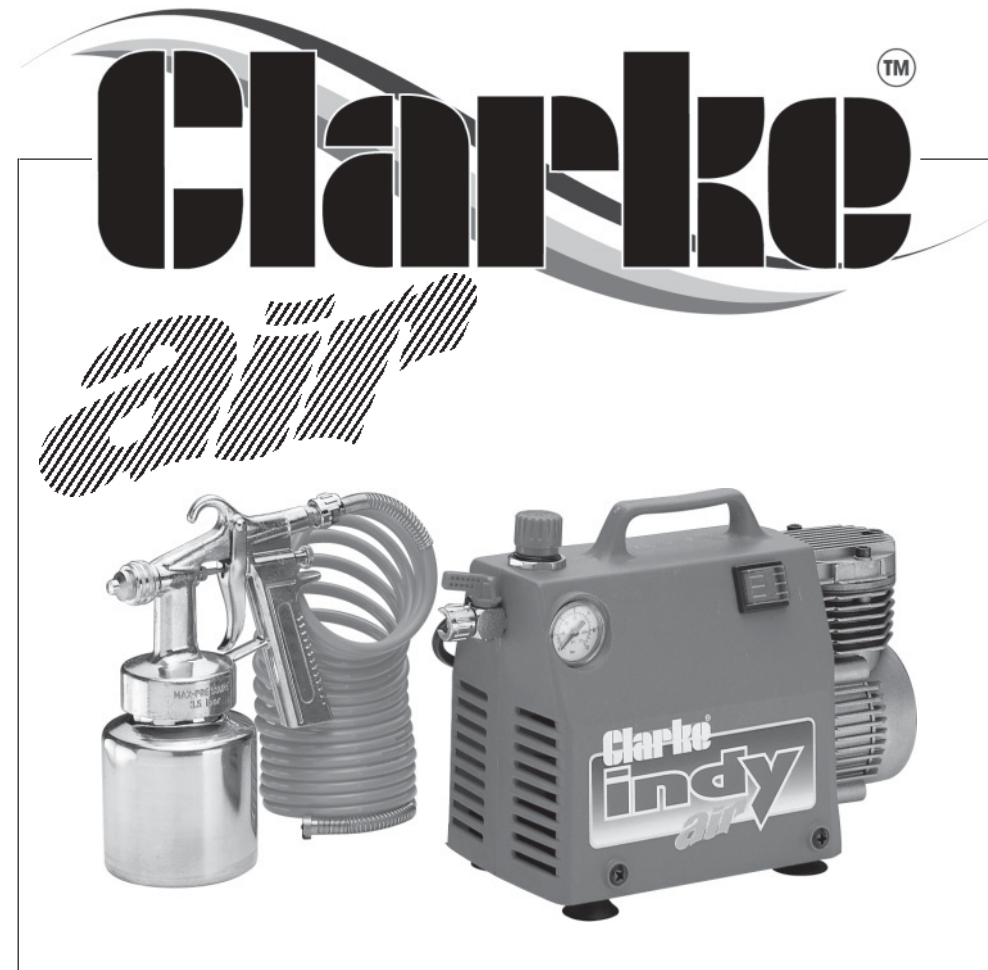

INDY OIL FREE AIR COMPRESSOR

OPERATION & MAINTENANCE INSTRUCTIONS

Serial/Batch No:

Clarke[®] INTERNATIONAL
For spare parts and servicing, please contact your nearest dealer, or Clarke International on
020 - 8988 - 7400
e-mail: Parts@clarkeinternational.com e-mail: Service@clarkeinternational.com



Please note that the details and specifications contained herein are correct at the time of going to print. However CLARKE International reserve the right to change specifications at any time without prior notice. Always consult the machines data plate

THIS PAGE LEFT INTENTIONALLY BLANK

ClarkeTM INTERNATIONAL

This is an important document and should be retained

DECLARATION OF CONFORMITY



We declare that this product complies with the following standards/directives:

- **IEC 34-1**
- **89/392/EEC**
- **EN 292-2**
- **EN 60 335 - 1**
- **89/336/EEC**

Description: **AIR COMPRESSOR**

Model No: **AIR INDY**

Serial (Batch) No: **See Product Date Plate**

Signed: 

Clarke[®] INTERNATIONAL
Hemnal Street, Epping, Essex CM16 4LG

ClarkeTM INTERNATIONAL

INDY AIR COMPRESSOR

Thank you for purchasing this Clarke Indy Air Compressor. Before attempting to operate the machine, please read this instruction manual thoroughly and carefully follow all directions given. This is for your own safety and that of others around you, and also to help you achieve long and trouble free service from your compressor.

Guarantee

This product is guaranteed against faults in manufacture for 12 months from purchase date. Please keep your receipt as proof of purchase. This guarantee is invalid if the product has been abused or tampered with in any way, or not used for the purpose for which it is intended. The reason for return must be clearly stated. This guarantee does not affect your statutory rights.

Contents



Page

Safety Precautions	4
Electrical Connections	5
Operating Instructions	6
General Arrangement	7
Paint Spraying Hints	8,9 & 10
Routine Maintenance	11
Fault finding	12
Technical data	13
Shutting down the compressor	13
Parts List & Diagrams - (JS Spraygun)	14 & 15
Parts List & Diagrams - (Compressor)	16 & 17
Declaration of Conformity	18

Safety Precautions

WARNING!

*Compressed air can be dangerous.
Follow these safety instructions carefully.*

- Never direct a jet of compressed air at people or animals, or spray paint towards people or animals.
-  Use appropriate protective equipment, such as Clarke safety-goggles or glasses, dust masks, ear defenders etc. when using compressed air tools.
-  Air compressors work at high pressure. Inspect equipment and hoses regularly, checking for any damage or leaks. Have any damage properly repaired before using the machine again.
- Do not operate the compressor with any guards removed.
- Do not adjust or tamper with the safety valve in any way. The maximum working pressure (115 psi - approximately 8 bar) is clearly marked on the compressor and air receiver.
- The compressor will become hot during operation. Do not touch the cylinder head or discharge pipe while the compressor is in use.
- Always close the air outlet valve and release any pressure from the air hose (by operating the tool briefly) before disconnecting any hoses or tools.

When paint spraying:

-  Always wear a suitably approved breathing mask when paint spraying, to protect against inhalation of paint spray or fumes. An airfeed mask may be required when spraying some types of paint. If in doubt, check the paint manufacturers instructions.
- Make sure there is adequate ventilation. Do not spray in confined or enclosed areas.
- Many paints are flammable. Do not smoke while spraying or preparing paints, or spray near a naked flame or heat source.

PARTS LIST (Compressor)

No	Description	Qty	No	Description	Qty
1	Screw	4	28	Hose Adapter	1
2	Compressor Head	1	31	Hose	1
3	Gasket	1	33	Pressure Gauge	1
4	Valve	1	34	Disk	1
5	Valve Plate	1	35	Screw	1
6	Gasket	1	36	Filter retainer	1
7	Screw	1	37	Air Filter	1
8	Piston Segment	1	38	Motor	1
9	Con-Rod	1	39	Bearing	1
10	Screw	4	40	On/Off Press Rel Valve	1
11	Crankcase	1	41	Pressure Gauge	1
12	Eccentric Shaft	1	42	Valve Block	1
13	Screw	4	43	Hose adapter	1
14	Base Plate	1	44	Pressure Rel Valve	1
15	Screw	1	45	Olive	1
17	Fan	1	46	Hose Connector	1
18	Motor Shaft	1	47	Hose	1
19	Capacitor	1	48	Hose Clamp	1
20	Plastic Cover	1	49	Hose	1
21	Bayonet Conn Nut	1	50	Power Cable	1
22	Tap	1	51	Cable	1
25	Pressure Regulator Assy	1			

PARTS DIAGRAM (Compressor)

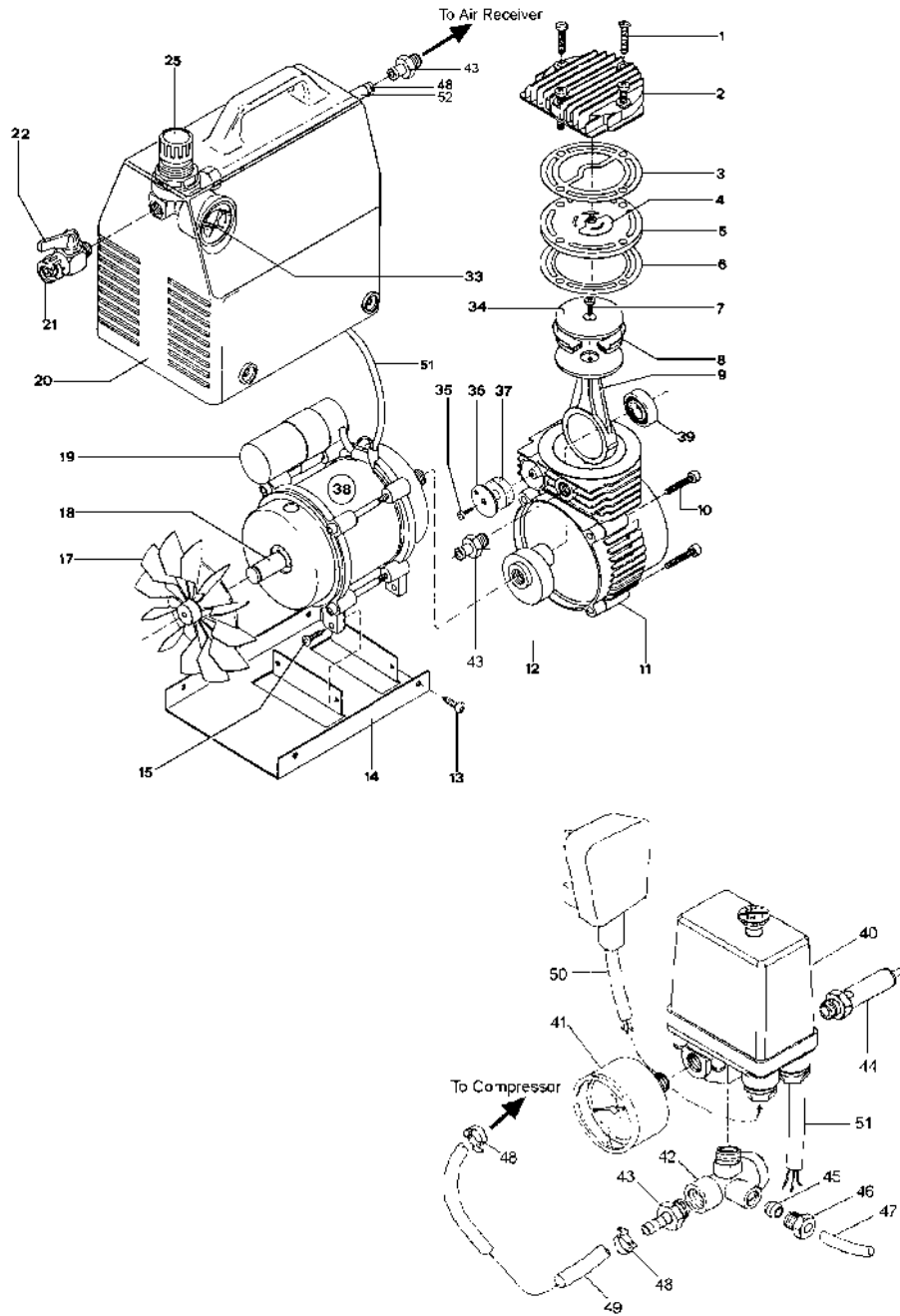

Electrical Connections

230 Volt models:

Connect the mains lead to a standard 230 Volt (50Hz) electrical supply through an approved BS1363, 13amp plug or a suitably fused isolator switch.

110 Volt models:

Connect the mains lead to a suitable 110 Volt (50Hz) electrical supply through an approved plug or a suitably fused isolator switch. If using a portable 110 Volt transformer make sure it has a rated capacity sufficient to take the load of the compressor (See Data Plate).

All models:

We recommend that the compressor is connected to the mains supply through a Residual Current Device (RCD).

⚠ WARNING! THIS APPLIANCE MUST BE EARTHED

IMPORTANT: The wires in the mains lead are coloured in accordance with the following code:

Green & Yellow	-	Earth
Blue	-	Neutral
Brown	-	Live

As the colours of the flexible cord of this appliance may not correspond with the coloured markings identifying terminals in your plug proceed as follows:

- Connect GREEN & YELLOW cord to terminal marked with a letter "E" or Earth symbol \perp or coloured GREEN or GREEN & YELLOW.
- Connect BROWN cord to terminal marked with a letter 'L' or coloured RED
- Connect BLUE cord to terminal marked with a letter 'N' or coloured BLACK

230 Volt models:

If this appliance is fitted with a plug which is moulded onto the electric cable (i.e. non-rewirable) please note:

1. The plug must be thrown away if cut from the electric cable. There is a danger of electric shock if it is subsequently inserted into a socket.
2. Never use the plug without the fuse cover fitted.
3. Should you wish to replace a detachable fuse carrier, ensure that the correct replacement is used (as indicated by marking or colour code).
4. Replacement fuse covers can be obtained from your local dealer or most electrical stockists.
5. The fuse in the plug must be replaced with one of the same rating (13amps) and this replacement must be ASTA approved to BS1362.

If in doubt, consult a qualified electrician....DO NOT attempt repairs yourself

OPERATION (Numbers in brackets refer to fig 1. Page 6)

1. Check that the mains voltage corresponds to that shown on the data sticker on the crankcase cover (5).
 2. Ensure that the on/off switch (4) is set to off, position 'O' and all air is expelled from the compressor by opening the outlet tap (3).
 3. Plug in and switch on the main electrical supply.
 4. To start the compressor, switch the on/off switch (4) to on, position 'I', the motor should start immediately.
 5. Before connecting your airline to the compressor, allow it to run for a few seconds with the air outlet tap (3) fully open.
 6. Close the air outlet tap, DO NOT OVERTIGHTEN, connect one end of suitable air hose to the compressor, and the other end to the equipment being used. Set the operating pressure by adjusting the regulator knob (1). To do this pull the knob upwards and adjust by turning (clockwise to increase and anti-clockwise to decrease). When the required pressure is reached on the pressure gauge (2) push the knob down again to hold the setting.
- NOTE: For most spray work, do not exceed 30psi (unless following paint manufacturers instructions). For other airline equipment such as tyre gauges, paraffin guns etc, it may be necessary to set the air pressure at a higher or (lower) level.
7. With operating pressure set, re-open the air outlet tap.

ACCESSORIES

Your Indy Air Compressor can be used in conjunction with a range of optional accessories, for inflating tyres, air brushing, stapling blowing and many other uses, For further details, please contact your nearest dealer.

Clarke INTERNATIONAL

PARTS LIST (JS Spraygun)

Item No	Description	Qty
1	Air Cap Ring	1
2	Air Cap	1
3	Air Cap	1
4	Fluid Tip	1
5	Washer	1
6	Packing Nut	1
7	Needle	1
8	Spring	1
9	Cap	1
10	Paint Feed Pipe	1
11	Container Gasket	1
13	Paint Container	1
14	Trigger	1
15	Pin	1
17	Nipple ¼"	1
18	Quick Release Nut	1

PARTS & SERVICE TEL: 020 8988 7400

or e-mail as follows:

PARTS: Parts@clarkeinternational.com

SERVICE: Service@clarkeinternational.com

PARTS DIAGRAM (JS Spraygun)

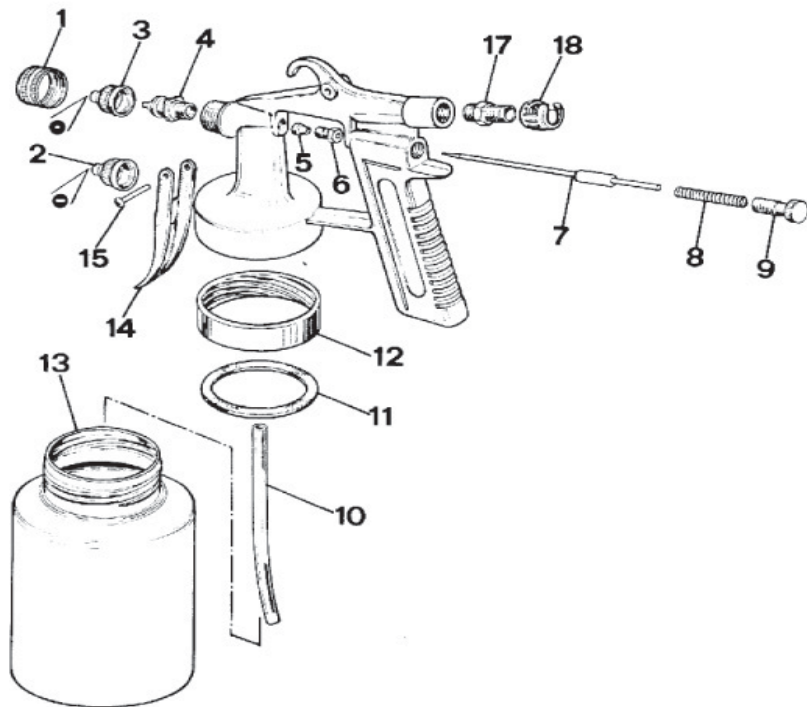

Clarke INTERNATIONAL

INDY SPRAY OUTFIT

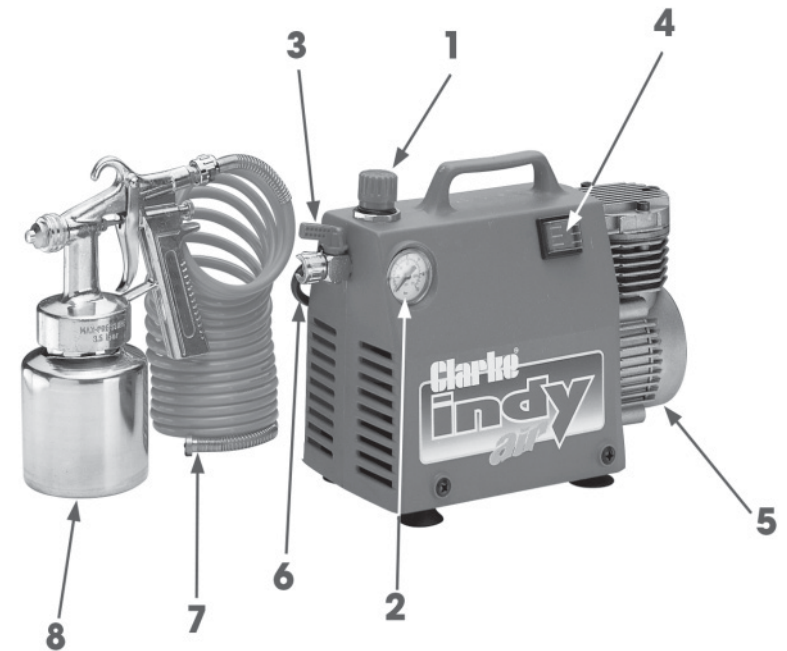

- | | |
|-----------------------------|-------------------------------|
| 1. Pressure regulator knob. | 6. Mains Lead.
(not shown) |
| 2. Pressure gauge. | 7. Recoil air hose. |
| 3. Air outlet tap. | 8. JS Spraygun. |
| 4. On/Off switch. | |
| 5. Crank case cover. | |

Clarke INTERNATIONAL

PAINT SPRAYING HINTS

WARNING

NEVER attempt to spray unless you are wearing suitable, approved respiratory and eye protection.

REMEMBER that some modern paints require specialist respiratory protection...always consult the paint manufacturers instructions.

1. GENERAL PREPARATION

- Ensure that the area in which you will be spraying is clean and dust free.
- Connect spray gun to compressor via suitable flexible hose.
- With no paint in spray gun, test system for air leaks.
- Cover adjacent pieces of equipment to prevent overspray. Mask areas of the article not to be sprayed.
- Ensure surface to be painted is clean, dry and free from oil and dust. Check paint manufacturer's instructions for any special surface preparation required.

REMEMBER - TIME SPENT PREPARING SAVES TIME SPENT FINISHING

2. PAINT PREPARATION

- Achieve the correct paint viscosity. This should be done according to paint manufacturer's instructions, and will vary according to type of paint.
- Having mixed the paint thoroughly in a separate container, pour into the spray gun paint container through a fine filter.

DO NOT OVERFILL SPRAY GUN PAINT CONTAINER - three quarters full is maximum

- It is usually best to experiment with a couple of practice spray coats on a piece of material with the same type of surface as the article you wish to spray, eg. metal for a car body panel, wood for a piece of furniture etc.
- Some common problems:

PROBLEM	CAUSE	CORRECTION
Paint does not atomise (comes out in blobs)	Paint is too thick, air pressure is too low.	Add thinners. Increase air press. (not above 50 psi, unless specified by paint manuf.
Paint dries before hitting surface, leaving it dry with a rough texture	Paint is too thin. Air pressure is too high	Add more paint. Reduce air pressure
Finish is pitted like Orange peel work	Air pressure too high or spray too close to gun and work.	Reduce air pressure, increase distance between

TECHNICAL DATA

Model	Indy Air - (Oil Free)
Maximum Air Pressure	115 PSI
Air Displacement	3.5 CFM
Motor	½ HP
Voltage	230 vac & 110 vac
Weight	9.6 kg (Packed)
Part Number Air Indy 110 Vac	3230071
Part Number Air Indy 230 vac	2320070
Dimensions (mm)	340 x 150 x 270

SHUTTING DOWN THE COMPRESSOR

- Ensure that the on/off switch is in the off - 'O' position.
NEVER USE THE MAINS SWITCH TO STOP THE MOTOR.
- Depress equipment trigger (spraygun) to release air from the hose and compressor before disconnecting from the machine.
- Switch off and remove mains.

FAULT FINDING

With considerate use, your CLARKE Air Compressor should provide you with long and trouble free service. Routine checks should be made on both the electrical supply as well as the compressed air lines and connections. If any fault appears, the reason for which is not immediately obvious, please contact your local CLARKE Dealer.

PROBLEM	PROBABLE CAUSE	REMEDY
The compressor stops and will not start again.	Bad connections. Overload cutout switch has tripped. Motor windings burnt out.	Check electrical connections. Clean and tighten as necessary. Switch off and wait 5 minutes before switching on. Contact your local dealer for a replacement motor.
The compressor does not reach the set pressure and overheats easily.	Compressor head gasket blown or valve broken.	Contact your CLARKE dealer. Replace Piston (contact your CLARKE dealer)
Compressor does not start.	Compressed air i cylinder head	Turn the air outlet tap off and disconnect hose (if fitted). Open the outlet tap and expel air from cylinder head. Restart

CAUTION Do not attempt any repair or adjustment if you are uncertain as to how it should be done. If you have any queries, contact your local CLARKE Dealer.

Clarke INTERNATIONAL

PAINT SPRAYING HINTS Cont

PAINT THINNING

For a professional looking finish paint must be thinned. If manufacturers recommendations on thinning are not available, the following can be used as a general guide.

- Water based paints (emulsions) 10-20% water.
- Oil based paints (gloss) up to 10% thinners.
- Cellulose paints up to 50 % cellulose thinners.

HANDLING THE GUN

the first requirement for a good resultant finish is the proper handling of the gun. The gun should be perpendicular to the surface being covered and moved parallel with it. The stroke should be started before the trigger is pulled and likewise , released before the stroke is ended. This gives accurate control of the gun and material.

The distance between the gun and the surface to be covered should be 6 to 12 inches depending on the material and atomising pressure. The material deposited should always be even and wet. Lap each stroke over the preceding stroke to obtain a uniform finish.

NOTE: To reduce overspray and obtain maximum efficiency, always spray with the lowest possible atomising air pressure.

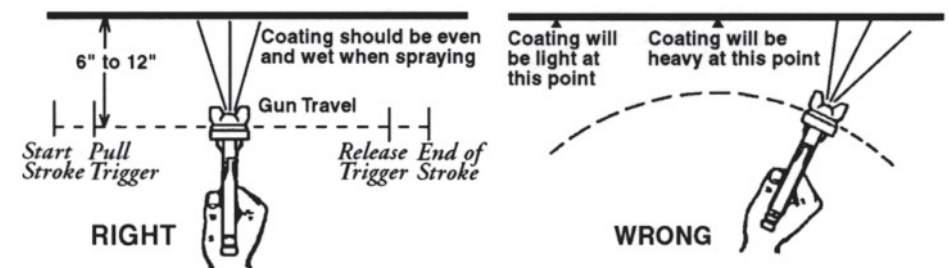

Clarke INTERNATIONAL

PAINT SPRAYING HINTS Cont

SPRAY GUN MAINTENANCE

- 1) Immerse only the front end of the gun until solvent just covers the fluid connection.
- 2) Use a bristle brush and solvent to wash off accumulated paint.
- 3) **Do Not** submerge the entire spray gun in solvent because:
 - a) The lubricant in the leather packings will dissolve and the packings will dry out.
 - b) The lubricant at wear surfaces will dissolve causing harder operation and faster wear.
 - c) Residue from dirty solvent may clog the narrow air passages in the gun.
- 4) Wipe down the outside of the gun with a solvent dampened cloth.
- 5) Lubricate the gun daily. Use a light machine oil on:
 - a) fluid needle packing.
 - b) Air valve packing.
 - c) Fan control packing.
 - d) Trigger pivot point.Coat the fluid control spring with vaseline.
- 6) **Caution:** Never use lubricants containing silicone. This material may cause contamination, leading to finish defects.

Clarke INTERNATIONAL

ROUTINE MAINTENANCE

IMPORTANT

Before attempting to service or carry out any maintenance or repairs on your Indy air compressor, always ensure that the unit is disconnected from the main electrical supply, i.e. mains plug removed, also ensure that all air has been expelled from the cylinder head.

NOTE: After the first 5 hours operation, check that all nuts and bolts are tight, paying special care to the compressor head and crankcase.

To keep your Indy compressor working efficiently, periodic servicing is necessary, follow the service schedules below.

Monthly:

Remove and clean the air intake filter element (37) (this should be carried out more frequently if the compressor is used in dusty atmospheres).

With SPONGE ELEMENTS gently blow clean with compressed air or wash in solution of household detergent.

Rinse and dry thoroughly before re-fitting.
Remember that a dirty filter prevents adequate aspiration and adversely affects the efficiency of your compressor.

WARNING:

Never operate the compressor without the air intake filter fitted.

YEARLY or 1000 HRS:

Replace the air intake element.

EVERY 2 YEARS or 2000 HRS:

Check and clean the intake and delivery valves.

WARNING:

When components are removed for servicing always take the opportunity to fit new seals.

In the event of an air leak, follow the procedure below:-

- a) Load the compressor to the maximum pressure.
- b) Un-plug the compressor from the main electrical supply.
- c) Using a brush and soapy water, wet all "screwed" connections. (Take care not to wet any electrical component).
- d) Any leaks will show up through the formation of bubbles.

NEVER UNSCREW A COMPRESSOR CONNECTION WHILE THE MACHINE IS UNDER PRESSURE. ALWAYS MAKE CERTAIN ALL AIR IS EXPELLED BEFORE DOING SO .