

ClarkeTM



COUGAR

OPERATING & MAINTENANCE
INSTRUCTIONS

CE

0903

Thank you for purchasing this Cougar Air Compressor which is available in two configurations - Cougar 25, fitted with a 24 litre air receiver and Cougar 50, fitted with a 50 litre receiver. These compressors are designed for DIY use ONLY.

Before attempting to operate the machine, please read this leaflet thoroughly and carefully follow the instructions given. In doing so you will ensure the safety of yourself and that of others around you, and you can also look forward to the compressor giving you long and satisfactory service.

GUARANTEE

This product is guaranteed against faulty manufacture for a period of 12 months from the date of purchase. Please keep your receipt as proof of purchase. This guarantee is invalid if the product is found to have been abused or tampered with in any way, or not used for the purpose for which it was intended. Faulty goods should be returned to their place of purchase, no product can be returned without prior permission. This guarantee does not effect your statutory rights.

CONTENTS

Page

Safety Precautions	4
Electrical Connections	5
Preparation for Use	6
Operation	6
Shutting Down	8
Maintenance	8
Fault Finding	10
Specifications	11
Accessories	11
Parts Lists and Diagrams	12 - 15
Parts and Service	2 - 15

SAFETY PRECAUTIONS

WARNING

As with all machinery, there are certain hazards involved with their operation and use. Exercising respect and caution will considerably lessen the risk of personal injury. However, if normal safety precautions are overlooked, or ignored, personal injury to the operator, or damage to property may result. It is in your own interest to read and pay attention to the following rules:

1. COMPRESSED AIR IS DANGEROUS, NEVER direct a jet of air at people or animals, and NEVER discharge compressed air against the skin.
2. DO NOT operate your compressor with any guards removed.
3. Electrical or mechanical repairs should only be carried out by a qualified engineer. If problems occur, contact your Clarke dealer.
4. Before carrying out any maintenance, ensure the pressure is expelled from the air receiver, and the machine is disconnected from the mains supply.
5. DO NOT leave pressure in the receiver overnight, or when transporting.
6. DO NOT adjust, or tamper with the safety valves. The maximum pressure is factory set, and clearly marked on the machine.
7. DO NOT operate in wet or damp conditions. Keep the machine dry at all times. Similarly, a clean atmosphere will ensure efficient operation. Do not use in dusty or otherwise dirty locations.
8. Some of the metal parts can become quite hot during operation. Take care not to touch these until the machine has cooled down.
9. Always adjust the pressure regulator to the recommended setting for the particular spray gun or tool being used.
10. When spraying inflammable materials e.g. cellulose paint, ensure that there is adequate ventilation and keep clear of any possible source of ignition.
11. Protect yourself. Think carefully about any potential hazards which may be created by using the air compressor and use the appropriate protection. e.g. Goggles will protect your eyes from flying particles. Face masks will protect you against paint spray and/or fumes.
12. Before spraying any material always consult paint manufacturers instructions for safety and usage.
13. Do not exert any strain on electrical cables and ensure that air hoses are not tangled or wrapped around machinery etc.
14. When disconnecting air hoses or other equipment from your compressor ensure that the air supply is turned off at the machine outlet and expel all pressurised air from within the machine and other equipment attached to it.
15. Make sure that children and animals are kept well away from the compressor and any equipment attached to it.
16. Always ensure that all individuals using the compressor have read and fully understand the Operating Instructions supplied.
17. Ensure that any equipment or tool used in conjunction with your compressor, has a safety working pressure exceeding that of the machine.

ELECTRICAL CONNECTIONS

Connect the mains lead to a standard, 230 Volt (50Hz) electrical supply through an approved 13 amp BS 1363 plug, or a suitably fused isolator switch.

WARNING! THIS APPLIANCE MUST BE EARTHED

IMPORTANT: The wires in the mains lead are coloured in accordance with the following code:

Green & Yellow	-	Earth
Blue	-	Neutral
Brown	-	Live

As the colours of the flexible lead of this appliance may not correspond with the coloured markings identifying terminals in your plug proceed as follows:

Connect GREEN & YELLOW cord to terminal marked with a letter "E" or Earth symbol $\frac{\perp}{\equiv}$ or coloured GREEN or GREEN & YELLOW.

Connect BROWN cord to terminal marked with a letter "L" or coloured RED.

Connect BLUE cord to terminal marked with a letter "N" or coloured BLACK.

If this appliance is fitted with a plug which is moulded onto the electric cable (i.e. non-rewireable) please note:

1. The plug must be thrown away if it is cut from the electric cable. There is a danger of electric shock if it is subsequently inserted into a socket outlet.
2. Never use the plug without the fuse cover fitted.
3. Should you wish to replace a detachable fuse carrier, ensure that the correct replacement is used (as indicated by marking or colour code).
4. Replacement fuse covers can be obtained from your local dealer or most electrical stockists.

FUSE RATING

The fuse in the plug must be replaced with one of the same rating (**13 amps**) and this replacement must be approved to BS1362.

We recommend that this machine is connected to the mains supply via a Residual Current Device (RCD)

If in any doubt, DO NOT attempt any connections or repairs yourself. Consult a qualified electrician, your Clarke dealer, or CLARKE International Service Dep't on

020 8988 7400 or e-mail Service@clarkeinternational.com

PREPARATION FOR USE

NOTE: All numbered items throughout this manual refer to the parts list item number on Pages 12 to 15

1. Remove the plastic travel plug from the oil filler hole, on the top of the crank case, and insert the dipstick (ref. 'A', Fig. 6 - p.9).
2. Check the oil level is at the correct level on the dipstick, as shown in Fig.1. Where necessary, top up with SAE40 Compressor Oil (Available from your local Clarke dealer).
3. Attach the wheels, foot and handle according to the instructions shown on the polythene bag containing the items (Cougar 25 only).

Fig.1

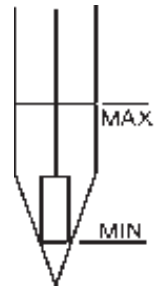

OPERATION

NOTE: If you intend using your compressor for spraying, read also the “Helpful Hints on Spraying” booklet - supplied with the machine.

1. Check that the mains voltage corresponds with that shown on the data sticker on the machine.
2. Ensure that the ON/OFF knob (see Fig. 2), is in the 'OFF' (0) position, i.e. pushed DOWN, then plug in and switch on at the mains supply.

Fig. 2

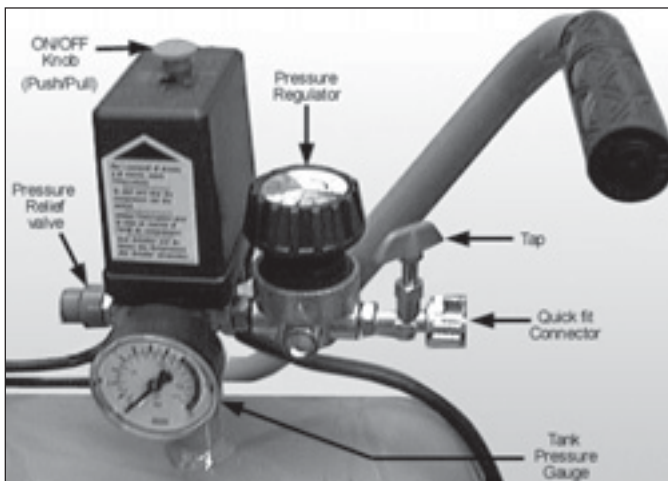

3. To start the compressor pull UP the ON/OFF knob to the 'ON' (I) position - the motor should start immediately.

Note: Should the motor fail to start immediately, it is probable that the air receiver is already full of air. Check the tank pressure gauge (see fig. 2). If you release air, by opening air outlet tap, the motor will start automatically once the cut-in pressure is reached.

4. Before connecting your airline to the compressor allow it to run with the air outlet tap completely open for 10 to 15 seconds to permit a good distribution of the lubricating oil.

5. Close the outlet tap then connect one end of suitable air hose to the compressor air outlet, and the other and to the equipment to be used.

Set the outlet pressure by adjusting the Output Pressure Regulator. To do this, turn the knob clockwise to increase pressure, anti-clockwise to decrease.

Align your desired pressure setting, shown on the top of the regulator knob, with the arrow on the casing.

Note: For most spraywork do not exceed 50 psi (unless following paint manufacturer's instructions).

For other airline equipment such as air tools, tyre gauges, staple guns, paraffin guns etc., it may be necessary to set the operating pressure at a higher (or lower) level.

IMPORTANT: Always refer to the accessory manufacturers' recommendations for optimum operating pressures for their equipment.

6. With operating pressure set, reopen the air outlet tap.
7. The Pressure Switch, located within the plastic cover beneath the ON/OFF knob, should not require adjustment. This is an automatic device and has been preset at the factory to stop the motor when pressure in the receiver reaches its maximum, and to start it again when the pressure falls to the minimum preset value. This operation is completely automatic and does not affect the spraying process in any way. However, should problems develop with the cut-in, cut out settings, consult your local Clarke dealer.

Note:

a. If the machine pumps continuously without cutting out then the compressor is too small for the application/tool being used, and damage may result. Consult your local Clarke dealer.

b. The motor is protected by a Thermal Overload so that if the motor overheats for any reason -the thermal overload will trip, stopping the motor. To restart, allow a period for the motor to cool down, (approx 5 mins), before pressing the Reset Button, arrowed in fig. 3. and shown at 'C', fig.6

Fig. 3

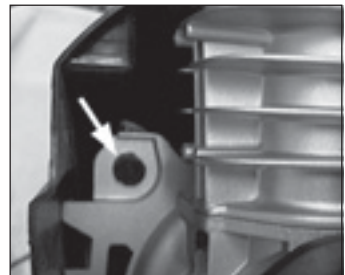

SHUTTING DOWN THE COMPRESSOR

1. To shut off the compressor, simply press **DOWN** on the **ON/OFF** knob (See Fig. 2) . Always use this knob to shut down the compressor. **NEVER USE THE MAINS SWITCH TO STOP MOTOR.**
2. Close the air outlet tap and trigger the equipment (spraygun, air tool etc) to release air from the air hose before disconnecting the hose from the machine.
3. Before transporting your compressor or when leaving overnight, expel all air from the receiver by opening drain valve located at the bottom of the receiver, and shown in fig 4.

MAINTENANCE

A. DAILY

1. Check the oil level before you start and top-up if necessary - (use Clarke SAE 40 compressor oil available from your local dealer).
2. Drain any condensate that may have accumulated in the receiver by unscrewing the drain plug beneath the air receiver (fig. 4).

Fig. 4



B. PERIODICALLY

1. After the first 5 hours of running the compressor, check the cylinder head bolts and motor housing screws and re-tighten if any have worked loose.
2. Every 50 hours (more frequently if used in a dusty environment), clean the air intake filter, by carefully prising the filter from the cover as shown in fig. 5
Clean the sponge and the inner housing. If necessary, the sponge filter may be gently washed in warm soapy water, rinsed and allowed to dry thoroughly before refitting. If the filter is damaged, you should obtain a replacement immediately.

Fig. 5



3. After the first 100 hours use, replace the oil completely using Clarke SAE 40 compressor oil. Thereafter, replace the oil completely after every 500 hours of operation or every 6 months.

To empty the oil from the machine, turn the screw located at the bottom of the plastic end cover, and shown at 'B' fig. 6, to the unlocked position, denoted by the symbol .

Ensure the screw is turned back to the locked position when completed



Fig. 6

4. Every 500 hours of operation or every 6 months

- clean all the external parts of the compressor.

(This cleaning makes the cooling process more efficient and prolongs the life of the machine).

Fig. 7

- Examine the non-return valve and renew parts if necessary (fig. 7)

(Ref: item 13, page 12 or item 8, page 13)

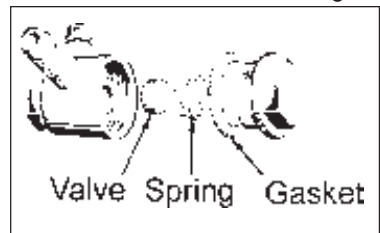

5. In the event of an air leak follow the procedure below:

- Load compressor to maximum pressure
- Unplug the compressor
- With a brush and soapy water wet all 'screwed' air connections
- Any leaks will show through the formation of air bubbles.

WARNING

**NEVER UNSCREW A CONNECTION WHILST THE AIR RECEIVER IS UNDER PRESSURE.
ALWAYS MAKE CERTAIN THAT THE TANK HAS FIRST BEEN EMPTIED.**

FAULT FINDING

PROBLEM	PROBABLE CAUSE	REMEDY
The compressor stops and will not start again.	<p>Bad connections.</p> <p>Blown fuse</p> <p>Overload cutout switch has tripped.</p>	<p>Check the electrical connections.</p> <p>Clean and tighten as necessary.</p> <p>Renew/Replace fuse</p> <p>Switch off and wait 5 minutes before pressing the reset button.</p>
The compressor does not reach the set pressure and overheats easily.	Compressor head gasket blown or valve broken.	<p>Wait for compressor to cool down, disassemble the head and replace any broken components.</p> <p>Carefully clean all sealing surfaces before reassembling.</p> <p>If in doubt contact your nearest dealer.</p> <p>NOTE: It is also possible that you are using more air than the compressor is capable of delivering.</p>
Compressor does not start.	Air receiver charged (see also item 1)	Open drain cock to expel air. Compressor should start again when pressure reduces to approx 95 psi.
Air leaking from the pressure switch valve when the compressor is not running.	Faulty non-return valve.	First drain the receiver completely of air. Remove the valve end plug, carefully clean the valve seat and the gasket and reassemble. See Fig 7.
Air pressure from the regulator will not adjust.	The diaphragm within the regulator body is broken.	Replace Regulator
The compressor is very noisy and makes a metallic knocking sound.	Compressor damaged and needs overhaul.	Return the machine to your nearest service agent.

SPECIFICATIONS

Motor	230V 50Hz 1Ph
Power Rating	1½ hp (1.1kW)
Rotational Speed	2850 RPM
Max. Pressure	8 bar (116psi approx)
Air Displacement	200l/min (7 cfm approx)
Receiver	COUGAR 25 24 LTR
	COUGAR 50 50 LTR
Cyl.Head Bolt Torque M6	8.80Nm
	M8 11.7Nm
Compressor Oil	CLARKE SAE 40
Fuse Rating	13amps
Part No.	COUGAR 25 2320910
	COUGAR 50 2320915
Duty Cycle	S3 40%*

***Compressor motor should not run for more than 4 minutes in any 10 minute period**

Please note that the details and specifications contained herein, are correct at the time of going to print. However, CLARKE International reserve the right to change specifications at any time without prior notice. Always consult the machine's data plate

ACCESSORIES

Your Clarke Cougar Air Compressor can be used in conjunction with a range of optional accessories for inflating tyres, air brushing, stapling, blowing and many other uses. For details contact your local accessory stockist. A complete kit is available from your Clarke dealer which is ideal for almost all applications.

Please quote part number 3110165



Should you experience any difficulties obtaining accessories, please contact the Clarke sales department (telephone 01992 565300) for details of your nearest dealer.

COUGAR 25

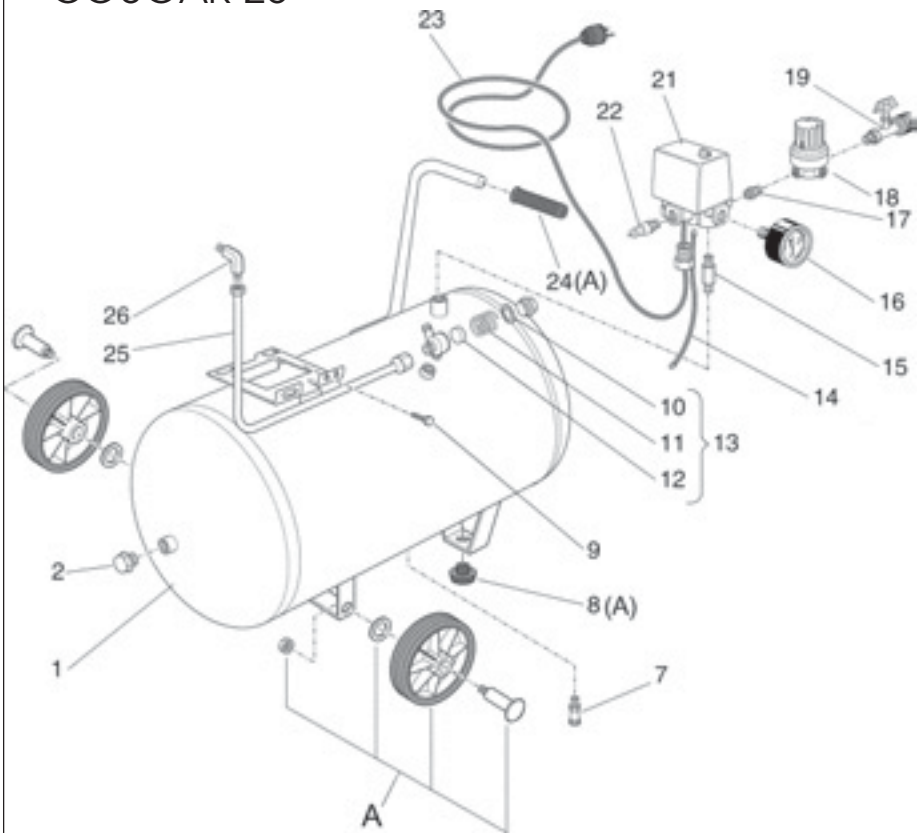

No.	Description	Part No.	No.	Description	Part No.
1	Reservoir	FN168HQ1000V	16	Pressure Gauge	FN330004000
2	End Plug	FN011008000	17	Adapter	FN011017000
7	Drain Valve	FN022020000	18	Pressure Regulator	FN319044000
8	Antivibration Pad	FN020146000	19	Tap Assembly	FN322007000
9	Screw	FN014013042	21	ON/OFF & Reg. Assy	FN321053000
10	Washer	FN010041000	22	Pressure Relief Valve	FN047165000
11	Spring	FN047113002	23	Mains Cable	FN101GA0200
12	Valve	FN047113001	24	Hand Grip	FN020147000
13	Valve Assembly compl.	FN347043000	25	Pipe	FN168HQ0003
14	Tube	FN046001000	26	Elbow	FN011015000
15	Connector	FN199110140	A	Wheel Kit	FN117HQ0001

COUGAR 50

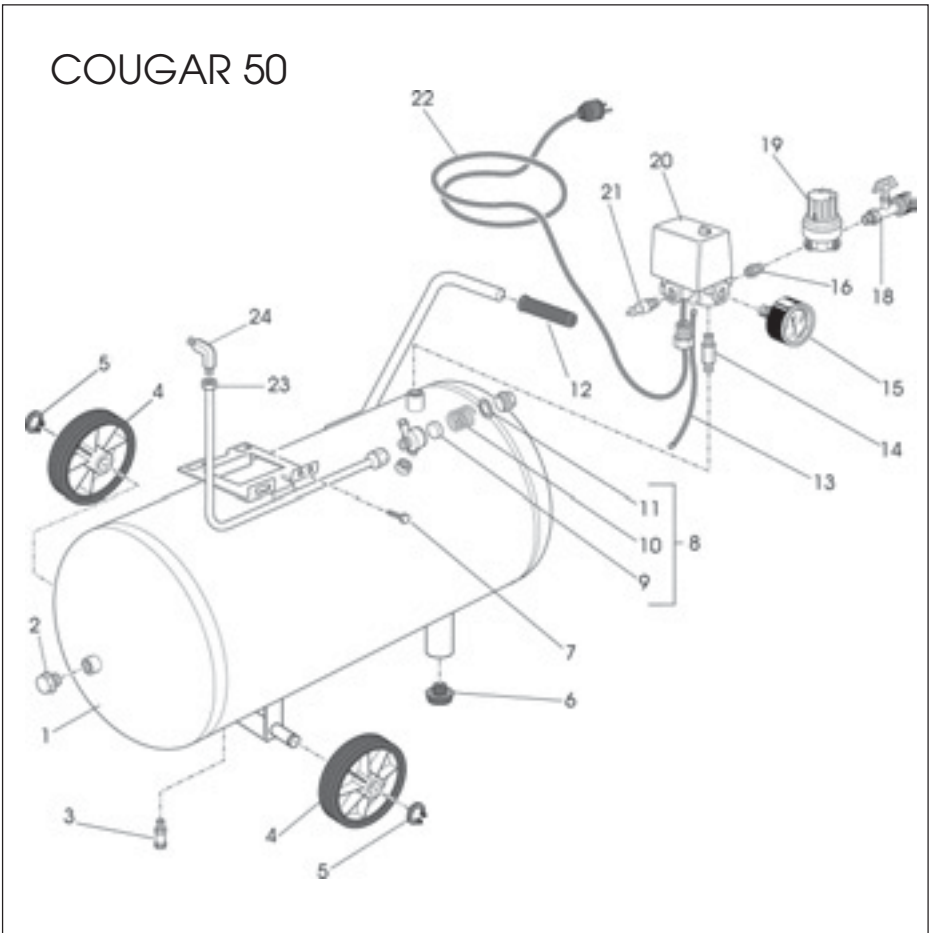

No.	Description	Part No.	No.	Description	Qty	Part No.
1	Reservoir	FN17005400V	13	Tube		FN046001000
2	End Plug	FN011008000	14	Connector		FN199110140
3	Drain Valve	FN022020000	15	Pressure Gauge		FN330004000
4	Wheel	FN020022000	16	Adapter		FN011017000
5	Circlip	FN015024000	18	Tap Assembly		FN322007000
6	Rubber Foot	FN020093000	19	Pressure Regulator		FN319044000
7	Screw	FN014013042	20	ON/OFF/Regulator Assy		FN321028000
8	Non-Return Valve Assy.	FN347034000	21	Pressure Relief Valve		FN347022000
9	Valve	FN347043000	22	Mains Cable		FN101GA0200
10	Spring	FN047113002	23	Pipe Assy.		FN168HQ0003
11	Washer	FN010041000	24	Elbow		FN011015000
12	Hand Grip	FN020121000				

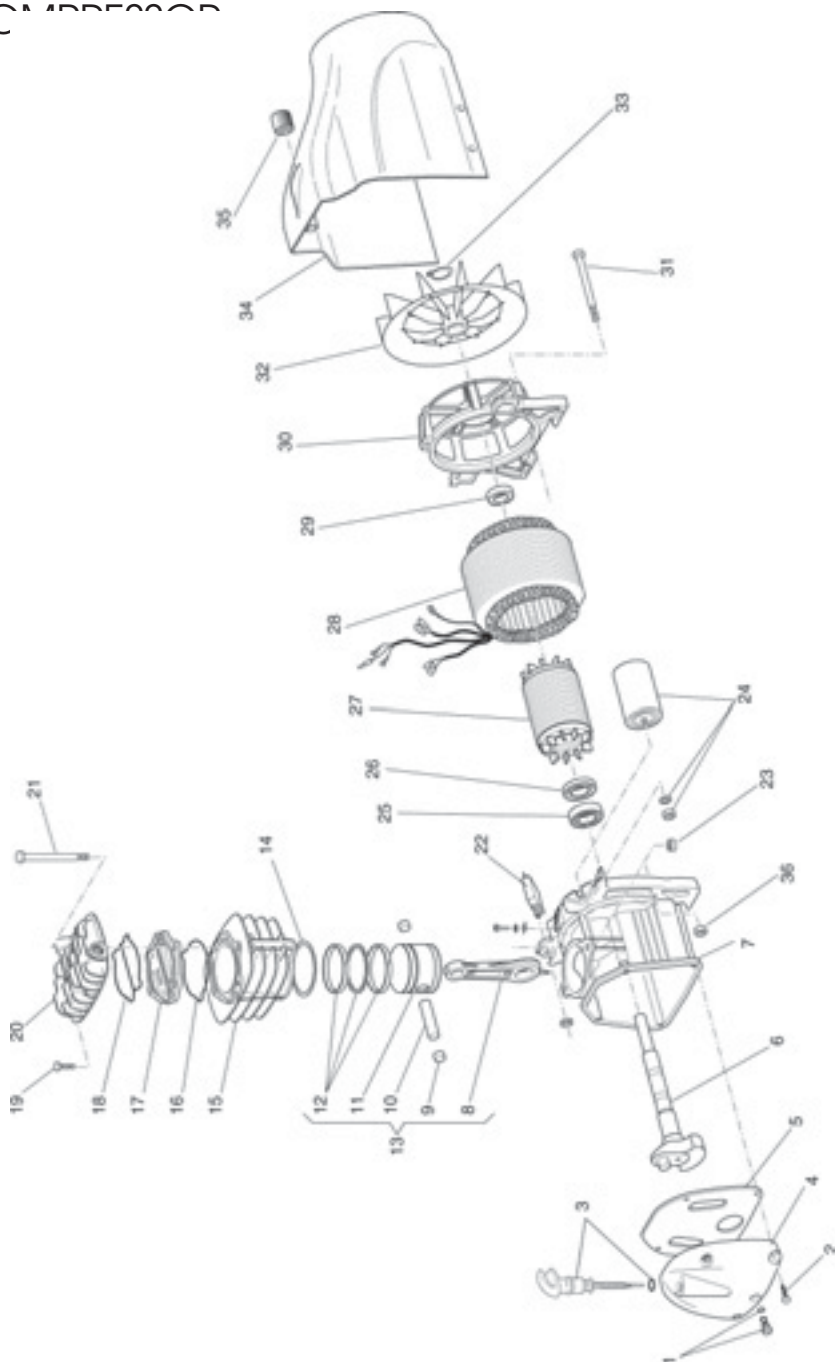

COMPRESSOR

No.	Description	Qty	Part No.	No.	Description	Qty	Part No.
1	Screw w/washer	1	FN216HQ0001	20	Cylinder Head	1	FN116120015
2	Screw	4	FN014006024	21	Cyl. Head Bolt M8	2	FN014001071
3	Dipstick compl.	1	FN216HQ0002	22	Overload protector	1	FN008040000
4	Plastic End Cover	1	FN116120002	23	Nut	2	FN014003018
5	Gasket	1	FB116120016	24	Capacitor	1	FN009200015
6	Shaft	1	FN116120004	25	Bearing	1	FN033082000
7	Housing	1	FN116120006	26	Seal	1	FN010132000
8	Con-Rod	1	FN116058004	27	Rotor	1	FN034036000
9	End Cap	2	FN116120011	28	Stator	1	FN316121604
10	Gudgeon Pin	1	FN113113003	29	Bearing	1	FN033005000
11	Piston	1	FN116120009	30	End Housing	1	FN116120007
12	Piston Ring set	1	FN216120003	31	Bolt	3	FN014002125
13	Piston Assy compl.	1	FN416120002	32	Fan	1	FN116120008
14	GasketGasket	1	FN010133000	33	Circlip	1	FN015083000
15	Cylinder	1	FN116121012	34	Plastic Cover	1	FN116121001
16	Gasket	1	FN116120013	35	Air Filter Element	1	FN116120017
17	Valve Block Assy.	1	FN116120100	36	Nut	3	FN014003021
18	Gasket	1	FN116120014	-	Full Set of Gaskets	1	FN216120001
19	Cyl. Head Screw M6	2	FN014013031				

SPARES AND SERVICING