

# CLAMPBO®

## CONTRACTOR®



### 15 DEGREE COIL NAILER

Model CON15

Part No: 3110295

## OPERATING & MAINTENANCE INSTRUCTIONS

CE

GC0309

---

## INTRODUCTION

---

Thank you for purchasing this CLARKE Coil Nailer

Before attempting to operate the machine, it is essential that you read this manual thoroughly and carefully follow all instructions given. In doing so you will ensure the safety of yourself and that of others around you, and you can also look forward to the product giving you long and satisfactory service.

---

## GUARANTEE

---

This CLARKE product is guaranteed against faulty manufacture for a period of 12 months from the date of purchase. Please keep your receipt as proof of purchase.

This guarantee is invalid if the product is found to have been abused or tampered with in any way, or not used for the purpose for which it was intended.

Faulty goods should be returned to their place of purchase, no product can be returned to us without prior permission.

This guarantee does not effect your statutory rights.

---

## ENVIRONMENTAL PROTECTION

---



Do not dispose of this product with general household waste. All tools, accessories and packaging should be sorted, taken to a recycling centre and disposed of appropriately.

---

## PARTS & SERVICE

---

For parts & Servicing, please contact your nearest dealer, or CLARKE International, on one of the following numbers.

**PARTS & SERVICE TEL: 020 8988 7400**

**PARTS & SERVICE FAX: 020 8558 3622**

**or e-mail as follows:**

**PARTS: [Parts@clarkeinternational.com](mailto:Parts@clarkeinternational.com)**

**SERVICE: [Service@clarkeinternational.com](mailto:Service@clarkeinternational.com)**

---

## OVERVIEW

---

The CON15 Coil Nailer is suitable for use on softwood, hardwood, plywood, hardboard, fibreboard or MDF, and will penetrate flexible plastics, leather, fabrics, PVC & rubber sheet materials. It is not suitable for piercing hard laminates, brittle plastics or metals (other than light foil).

Unpack and lay out the components, checking against the following list. Any damage or deficiency should be reported to your Clarke dealer immediately.

- Coil Nailer
- Oil Bottle
- 4 x Hexagonal Keys (3 ,4, 5 & 6mm)
- 1 x Nail Roll
- Black Moulded Case
- Operators Manual (this document)

Your Coil Nailer has been designed to give long and trouble free service. If, however, having followed the instructions in this booklet carefully, you encounter problems, take the unit to your local Clarke dealer.

---

## TECHNICAL SPECIFICATION

---

Feature	Specification
Weight	4 kg
Dimensions (lxwxh) mm	330 x 130 x 355
Operating Air Pressure	70-100 psi (4.8-6.9bar)
Max Air Pressure	120 psi (8.2 bar)
Drive Speed	300 nails/min
Compressed Air Consumption	6.5 cfm
Airline Connection	1/4" BSP male
Magazine Capacity	300 nails

Please note that the details and specifications contained herein, are correct at the time of going to print. However, CLARKE International reserve the right to change specifications at any time without prior notice.

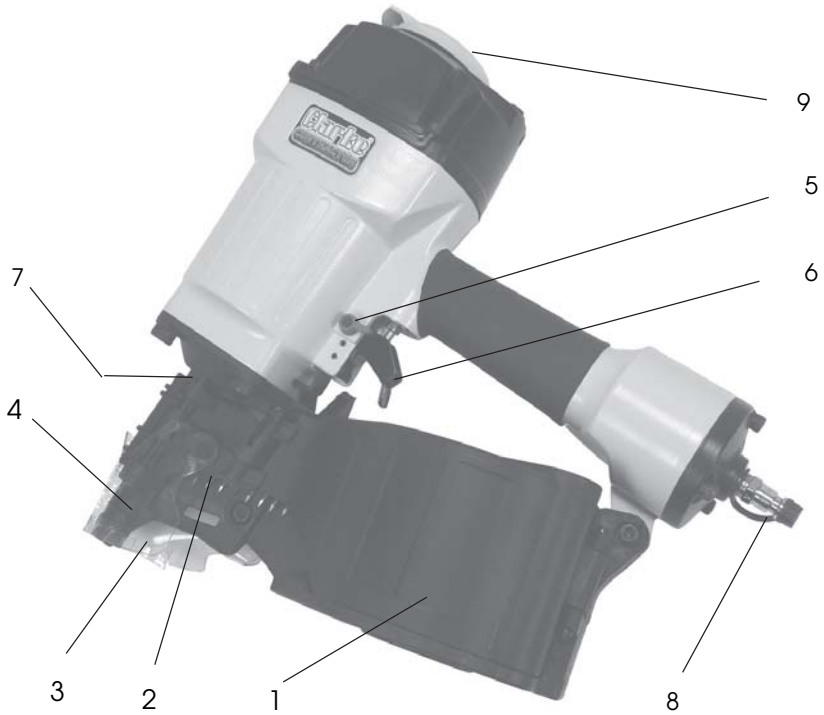

1. Nail Magazine
2. Drive Pawl
3. Protective Screen
4. Safety Yoke (muzzle)
5. Mode Switch (single/full contact sequential actuation)
6. Trigger
7. Pressure Adjuster
8. Compressed Air Hose Connector
9. Exhaust Deflector

---

# GENERAL SAFETY PRECAUTIONS

---

## WORK AREA

1. **ALWAYS** Keep the work area clean and well lit. Floors should always be kept clear. Cluttered or dark areas invite accidents.
2. **ALWAYS** keep children and bystanders away while operating a power tool. Distractions can cause loss of control.

## PERSONAL SAFETY

1. **ALWAYS** stay alert, watch what you are doing and use common sense when operating a power tool. Do not use a power tool while you are tired or under the influence of medication, drugs or alcohol. A moment of inattention can result in personal injury.
2. **ALWAYS** use safety equipment when operating this tool. Always wear suitable protective clothing and eye protection including industrial gloves, ear defenders and approved impact resistant safety glasses. (Eye glasses are NOT safety glasses)
3. **NEVER over-reach**. Keep your proper footing and balance at all times to enable better control of the machine in unexpected situations.
4. **NEVER** point the tool at anyone or any part of your own body. Keep all parts of your limbs behind the safety guard at all times.
5. **ALWAYS** keep a safe distance between yourself and others when using the tool.
6. **NEVER** attempt any repairs yourself. If you have a problem with the machine contact your local Clarke dealer.
7. **ALWAYS** store power tools out of reach of children.
8. **ALWAYS** dress properly. Never wear loose clothing or jewellery which could be caught on moving parts.

## GENERAL POWER TOOL USE AND CARE

1. **NEVER** force or misuse the tool. It will do a better and safer job at the rate for which it was designed.
2. **ALWAYS** maintain the tool with care and keep it clean for best / safest performance.
3. **NEVER** use this tool if any part is damaged. Have it inspected and repaired by a competent technician.
4. **NEVER** modify this tool in any way. Use it ONLY for the purpose for which it is designed.
5. **NEVER** carry the tool with your finger on the trigger. The nailer is fitted with a safety yoke mechanism to prevent accidental firing.

6. **ALWAYS** disconnect the tool from the air supply when not in use, and before carrying out any maintenance or re-loading with fresh nails.
7. **ALWAYS** Store the tool out of reach of children.
8. **NEVER** allow persons unfamiliar with these instructions to operate this tool.

## SERVICING

1. **ALWAYS** have power tools serviced by your Clarke dealer, using only identical replacement parts. This will ensure the safety of the power tool is maintained.

## COIL NAILER SAFETY INSTRUCTIONS

1. Although the Coil Nailer is water resistant and may be used outdoors, DO NOT leave it exposed to the elements. Avoid direct sunlight, direct heat, rain/moisture etc.
2. **ALWAYS** keep the air hose away from the nailer and ensure that the operator is not restricted by the length of the hose.
3. **ALWAYS** take care when a long air hose is required in the work area as it presents a trip hazard. Coil the hose away as soon as the job is finished.
4. **NEVER** abuse hoses or connectors. NEVER carry a tool by the hose, or yank it to disconnect from the air supply. Keep hoses away from heat, oil and sharp edges. Check hoses for leaks or worn condition before use, and ensure that all connections are secure.
5. **NEVER** use with an air supply greater than 8.2 bar (120 PSI).
6. **NEVER** use any other type of gas such as bottled oxygen or other bottled gas as a power source to operate this tool. Use compressed air ONLY.
7. **NEVER** load the tool with the trigger depressed in case of accidental firing.
8. **NEVER** fire tool at an incline. It must be perpendicular to the work surface.
9. **NEVER** drive in nails at the edge of a work surface, as the edge could fail and fly off, endangering yourself or others in the vicinity.
10. **ALWAYS** take care not to fire a nail into an existing metal fastening in case the nail should ricochet causing personal injury.
11. **NEVER** operate the tool unless the safety nose is in contact with the workpiece, or without any nails or damage to the tool could result.
12. **ALWAYS** keep hands away from the nose of the tool when connecting to the compressed air supply.
13. **ALWAYS** ensure only the correct nails are used, as specified for this tool.

# THE COMPRESSED AIR SUPPLY



**WARNING: COMPRESSED AIR CAN BE DANGEROUS. ENSURE THAT YOU ARE THOROUGHLY FAMILIAR WITH SAFETY PROCEDURES RELATING TO THE USE OF COMPRESSORS AND COMPRESSED AIR SUPPLIES.**

A filtered, lubricated and regulated air supply will be required as shown in the layout below.

Ensure the pressure available is within the range of 70-100 psi. Higher pressure or contaminated air will shorten the tool's life because of increased wear, and could be a safety hazard. Higher pressure will also increase the noise level.

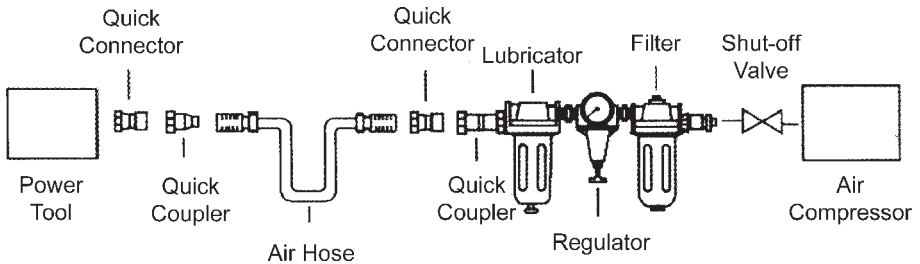

The air inlet used for connecting the air supply has a standard  $\frac{1}{4}$ " BSP thread. For best performance, a quick-fit connector can be used at each end of the line.

Line pressure, or hose internal diameter should be increased to compensate for unusually long air hoses (over 10m). Minimum hose diameter should be 6mm ( $\frac{1}{4}$ " ID), and fittings should have the same internal dimensions.

Check the quality of the compressed air supply before starting work. Water in the air line will cause damage to the tool, and a dirty filter will reduce the available air pressure.

Ensure there are no leaks in any of the connections.

## LOADING THE COIL NAILER



**WARNING: ENSURE THE COMPRESSED AIR SUPPLY IS DISCONNECTED BEFORE ATTEMPTING TO LOAD THE COIL NAILER. DO NOT HOLD THE TRIGGER WHILE LOADING THE NAILER.**

The machine is loaded with nails as follows:

1. Press the latch (1) open and pull the magazine cover (2) back.
2. Knowing the nail size to be used, raise and twist the adjuster 90 degrees for the chosen nail size as required.

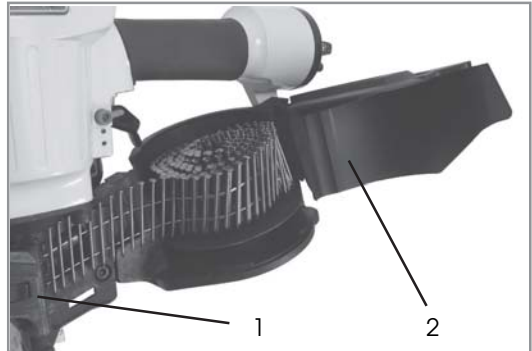

3. Insert a strip of nails into the magazine, (pointed end downwards), taking care that the strip is wound evenly around the centre spigot (3) of the height adjuster (4). Note that 3 different nail sizes can be used, as indicated by the markings on the inside of the magazine. The sizes available are listed on page 12.

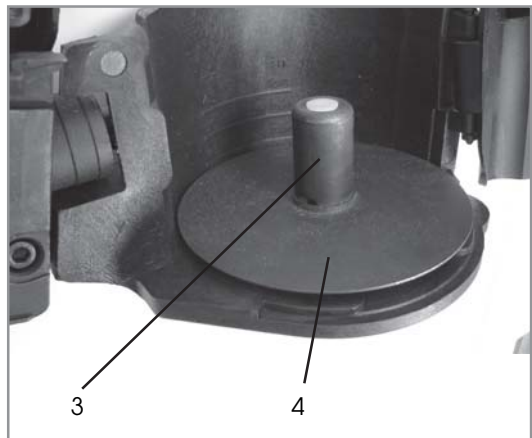

4. Take care when handling the nails, that they do not become bound together.



5. Offer the end of the strip of nails into the gun, taking care that the nail heads lay flat in the groove (5) closest to the machine body and that the first nail in the strip is resting in the drive pawl (6).
6. Close the magazine cover and close the latch.
  - This will not be possible if the nails are not positioned correctly. The machine is now ready to use.

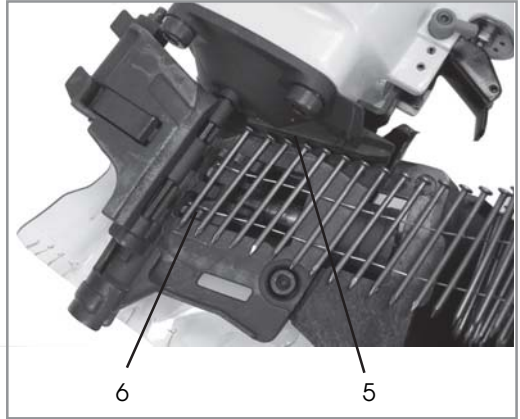

## OPERATION

1. Connect the nailer to the air supply. With the air supply turned OFF, connect the air line to the ¼" BSP connector. (A Whip Hose with quick-fit coupling is available from your Clarke dealer).
2. Turn ON the air supply.
  - Check for air leaks. If any are apparent, rectify before proceeding.
3. Ensure the operating pressure is set to between 70-100psi . This may be adjusted, dependant upon the density of the workpiece. The harder the target material, the higher the air pressure required. e.g. When nailing into softwoods, a pressure of only 70psi may be all that is required.



Quick release Airline Connection



**NEVER OPERATE THE TOOL UNLESS THE SAFETY YOKE IS IN CONTACT WITH THE WORKPIECE, OR WITHOUT ANY NAILS OR DAMAGE TO THE TOOL COULD RESULT.**

4. Before starting work, test the nailer on a piece of scrap wood to check that the driving depth is correct. If the nails are being driven too far or not deep enough into the timber, adjust the air pressure adjuster located on the side of the nose section accordingly. (Remember; whatever pressure adjustment is to be carried out on the tool is dependant upon the pressure received from the airline).



Pressure adjuster

5. Hold the tool so that it is at right angles to the workpiece. Lower it so that the yoke contacts the work surface and with a slight downwards pressure, pull the trigger to drive in the nail.

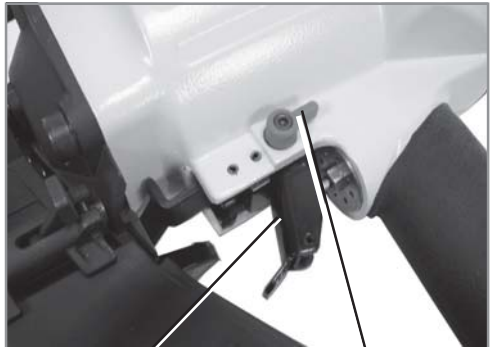

Trigger

Mode Switch

6. The machine is equipped with a switch that can change the operating mode from single shot to sequential shots. When the red switch is pointing towards the operator, the coil nailer will fire a single nail only. To fire the next nail the trigger must be released. When the switch is pointing away from the operator, the nailer can fire sequentially.

7. An adjustable exhaust deflector is fitted. Turn the deflector into any chosen position to avoid the blast from the exhaust.



Deflector

## CLEARING A JAM

Should the coil nailer jam; for example, with the last nail of a batch, disconnect the air supply and pull the trigger to ensure the air line is not under pressure. Open the magazine and latch and clear the jam before re-loading.

---

# MAINTENANCE

---



**WARNING: ENSURE THE COMPRESSED AIR SUPPLY IS DISCONNECTED BEFORE ATTEMPTING ANY MAINTENANCE ON THE COIL NAILER.**

---

## DAILY BEFORE USE

1. Check and clean, if necessary, the air inlet gauze filter located inside the air hose connection point.
2. A bottle of Clarke airline oil is supplied with the Coil Nailer. Unscrew the cap & withdraw the nozzle which is reversed within the neck of the bottle. Screw the cap and nozzle correctly into place and squirt a few drops of oil, into the air inlet. This should be carried out regardless of whether or not an air line lubricator is used.
3. Inspect the tool for worn or damaged parts, or for any loose screws or bolts.
4. Examine the trigger mechanism for free movement.
5. Keep magazine and yoke of the tool free of grime or abrasive particles.
6. If working conditions are below freezing it is advisable to keep air tools warm by storing them in a warmer place.

## DURING USE

For lubricating the internal components when in operation, an airline lubricator should be used, with Clarke Airline Oil, adjusted to 2 drops per minute.

If an airline lubricator is NOT used, this procedure should be repeated after every two to three hours of use.

Make a regular inspection of the trigger, spring and safety mechanism for free movement.

## AIRLINE WORKING CONDITIONS

Be aware that factors other than the tool's condition may effect it's operation and efficiency. Anything which will reduce the air supply, such as reduced compressor output, excessive demand on the airline, moisture or restrictions in the line, or the use of connectors of improper size or poor condition will all reduce tool performance.

Grit or gum deposits in the tool may also reduce efficiency. This condition can be corrected by cleaning the air strainer and flushing out the tool with gum solvent oil, or failing this, the tool should be dismantled, thoroughly cleaned, dried and reassembled. This is a task for your Clarke dealer.

If the tool runs erratically or becomes inefficient, and the air supply is sound, it will be necessary to dismantle the piston assembly and replace worn or damaged parts, which is best carried out by your Clarke dealer.

## STORAGE

If the Coil Nailer is to be stored, or is idle for longer than 24 hours, run a few drops of Clarke airline oil into the air inlet before storing.

Ensure the protective cap is replaced on the airline connector, once the airline is disconnected.

---

## ACCESSORIES & CONSUMABLES

---

A wide range of airline accessories is available, including Filter/Regulators, Lubricators, High Pressure Hoses from 5 to 100 metres, Whip Hoses etc. Contact your Clarke dealer for further information, or Clarke International Sales Department on 01992 565333.

**Wire-collated nails are available for the CON15 in three sizes:**

<b>Part No</b>	<b>Nail Size</b>
1800462	2.3 x 44mm Nails (300pcs)
1800464	2.5 x 50mm Nails (300pcs)
1800466	2.9 x 70mm Nails (250pcs)

Clarke airline oil (1 litre) is available from your Clarke dealer; Part No 3050825

**IMPORTANT:** The use of parts other than genuine Clarke replacement parts may result in safety hazards, decreased tool performance and will invalidate your warranty.

# TROUBLESHOOTING

SYMPTOM	PROBLEM	SOLUTION
Air leak near top of tool or in the trigger area.	<ol style="list-style-type: none"> <li>1. O-ring in trigger valve area damaged.</li> <li>2. Trigger valve head is damaged.</li> <li>3. Trigger valve stem, seal or O-ring are damaged.</li> </ol>	<ol style="list-style-type: none"> <li>1. Examine &amp; replace O-ring</li> <li>2. Examine &amp; replace.</li> <li>3. Examine and replace trigger valve stem, seal or O-ring.</li> </ol>
Air leak near bottom of tool.	<ol style="list-style-type: none"> <li>1. Loose screws.</li> <li>2. Worn or damaged O-ring or bumper.</li> </ol>	<ol style="list-style-type: none"> <li>1. Tighten screws</li> <li>2. Examine &amp; replace O-ring or bumper.</li> </ol>
Air leak between body and cylinder cap.	<ol style="list-style-type: none"> <li>1. Loose screws..</li> <li>2. Worn or damaged O-rings or seals..</li> </ol>	<ol style="list-style-type: none"> <li>1. Tighten screws.</li> <li>2. Examine &amp; replace O-ring or bumper.</li> </ol>
Nails are being driven in too deep.	<ol style="list-style-type: none"> <li>1. Worn bumper.</li> <li>2. Air pressure set too high.</li> </ol>	<ol style="list-style-type: none"> <li>1. Replace bumper.</li> <li>2. Adjust air pressure.</li> </ol>
Tool does not drive nail well or is operating sluggishly.	<ol style="list-style-type: none"> <li>1. Inadequate air supply.</li> <li>2. Inadequate lubrication.</li> <li>3. Worn or damaged O-ring or seal.</li> <li>4. Exhaust port in cylinder head is blocked.</li> </ol>	<ol style="list-style-type: none"> <li>1. Confirm adequate air supply</li> <li>2. Insert 2-6 drops of oil into air inlet.</li> <li>3. Examine &amp; replace O-ring or seal.</li> <li>4. Replace damaged internal parts.</li> </ol>
Tool fails to fire all the nails in turn.	<ol style="list-style-type: none"> <li>1. Worn bumper or damaged spring.</li> <li>2. Dirt in front plate.</li> <li>3. Grime or damage stops nails from moving freely in magazine.</li> <li>4. Worn or dry O-ring on piston,/lack of lubrication.</li> <li>5. Cylinder cover seal leaking.</li> </ol>	<ol style="list-style-type: none"> <li>1. Replace bumper or pusher spring.</li> <li>2. Clean drive channel on front plate.</li> <li>3. Clean grime out of magazine.</li> <li>4. Examine &amp; replace O-ring.</li> <li>5. Replace sealing washer.</li> </ol>
Tool jams.	<ol style="list-style-type: none"> <li>1. Incorrect or damaged fasteners.</li> <li>2. Damaged or worn driver guide.</li> <li>3. Magazine or nose screw loose.</li> <li>4. Magazine is dirty.</li> </ol>	<ol style="list-style-type: none"> <li>1. Change and use correct fasteners.</li> <li>2. Examine and replace the driver.</li> <li>3. Tighten the magazine.</li> <li>4. Clean the magazine.</li> </ol>

In the event that any of the above situations occurs, requiring the dismantling and overhaul of the tool, contact your Clarke International Service Department on 020-8988-7400.

## PARTS LIST

No	Description	Part No
1	Bolt	HTCON15001
2	Air Deflector	HTCON15002
3	Spring Plate	HTCON15003
4	Cylinder Bolt	HTCON15004
5	Hex Bolt	HTCON15005
6	Gun Body Protector	HTCON15006
7	Cylinder Cover	HTCON15007
8	Hex Headed Bolt	HTCON15008
9	Spring Washer	HTCON15009
10	Spring Base	HTCON15010
11	Balance Valve Spring	HTCON15011
12	Balance Valve Assembly	HTCON15012
13	Collar	HTCON15013
14	O - Ring	HTCON15014
15	Driver Blade	HTCON15015
16	O - Ring	HTCON15016
17	Fixed Ring	HTCON15017
18	O - Ring	HTCON15018
19	O - Ring	HTCON15019
20	Cylinder	HTCON15020
21	Outside Bumper Washer	HTCON15021
22	Inside Bumper Washer	HTCON15022
23	Cylinder Cover Plate	HTCON15023
24	Gun Body	HTCON15024
25	O - Ring	HTCON15025

No	Description	Part No
26	Valve O - Ring	HTCON15026
27	O - Ring	HTCON15027
28	Valve Sleeve	HTCON15028
29	O - Ring	HTCON15029
30	O - Ring	HTCON15030
31	O - Ring	HTCON15031
32	Trigger Spring	HTCON15032
33	Trigger Pole	HTCON15033
34	O - Rings	HTCON15034
35	O - Rings	HTCON15035
36	Switch Knob	HTCON15036
37	Pin	HTCON15037
38	Sliding Base	HTCON15038
39	Trigger	HTCON15039
40	Safety Nose	HTCON15040
41	Pin	HTCON15041
42	Adjusting Pin	HTCON15042
43	Spring	HTCON15043
44	Cap	HTCON15044
45	Hex Bolt	HTCON15045
46	Bolt	HTCON15046
47	O - Ring	HTCON15047
48	O - Ring	HTCON15048
49	Driver Guide	HTCON15049
50	Adjusting Knob	HTCON15050

# PARTS LIST

No	Description	Part No
51	Adjusting Bolt	HTCON15051
52	Compression Spring	HTCON15052
53	Adjusting Bolt	HTCON15053
54	Hex Bolt	HTCON15054
55	Pawl	HTCON15055
56	Pawl Spring	HTCON15056
57	Pin	HTCON15057
58	3 - Pin	HTCON15058
59	O - Ring	HTCON15059
60	Piston	HTCON15060
61	O - Ring	HTCON15061
62	Spring	HTCON15062
63	Piston Bump Washer	HTCON15063
64	Spring Base	HTCON15064
65	Snap Retainer	HTCON15065
66	Cover Board	HTCON15066
67	Connecing Rod	HTCON15067
68	Compression Spring	HTCON15068
69	Pawl	HTCON15069
70	Pin	HTCON15070
71	Compression Spring	HTCON15071
72	Pin	HTCON15072
73	Pin	HTCON15073
74	Compression Spring	HTCON15074
75	Safety Stand	HTCON15075

No	Description	Part No
76	Magazine	HTCON15076
77	Magazine Cover	HTCON15077
78	Anvil	HTCON15078
79	2-Spring Hook	HTCON15079
80	Adjusting Plate	HTCON15080
81	Aluminium Plate	HTCON15081
82	Adjusting Sleeve	HTCON15082
83	Nail Depth Adjusting Base	HTCON15083
84	Rubber Washer	HTCON15084
85	Spring	HTCON15085
86	Hex Bolt	HTCON15086
87	2 - Bolt	HTCON15087
88	Hex Bolt	HTCON15088
89	Fixed Ring	HTCON15089
90	Nail Head Cover	HTCON15090
91	Protective Film	HTCON15091
92	Washer	HTCON15092
93	Fixed Rubber Washer	HTCON15093
94	Grip	HTCON15094
95	End Plate Washer	HTCON15095
96	End Plate	HTCON15096
97	Sping Washer	HTCON15097
98	Hex Headed Bolt	HTCON15098
99	Air Inlet Plug	HTCON15099
100	Plug Cap	HTCON15100

# PARTS DIAGRAM

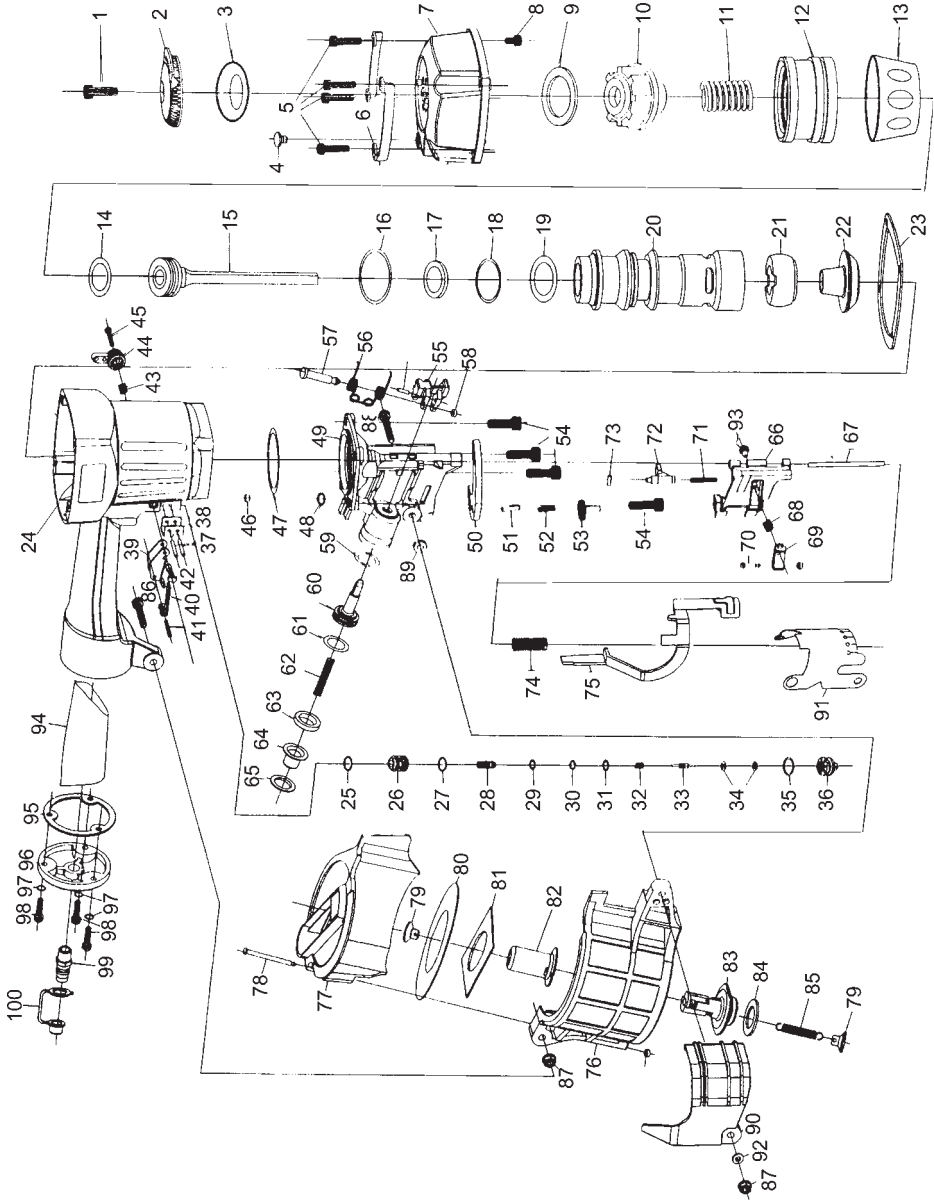



---

# VIBRATION EMISSIONS

---

## HAND-ARM VIBRATION

*Employers are advised to refer to the HSE publication "Guide for Employers".*

All hand held power tools vibrate to some extent, and this vibration is transmitted to the operator via the handle, or hand used to steady the tool. Vibration from about 2 to 1500 herz is potentially damaging and is most hazardous in the range from about 5 to 20 herz.

Operators who are regularly exposed to vibration may suffer from Hand Arm Vibration Syndrome (HAVS), which includes 'dead hand', 'dead finger', and 'white finger'. These are painful conditions and are widespread in industries where vibrating tools are used.

The health risk depends upon the vibration level and the length of time of exposure to it.....in effect, a daily vibration dose.

Tools are tested using specialised equipment, to approximate the vibration level generated under normal, acceptable operating conditions for the tool in question. For example, a grinder used at 45° on mild steel plate, or a sander on softwood in a horizontal plane etc.

These tests produce a value 'a', expressed in metres per second per second, which represents the average vibration level of all tests taken, in three axes where necessary, and a second figure 'K', which represents the uncertainty factor, i.e. a value in excess of 'a', to which the tool could vibrate under normal conditions. These values appear in the specification panel below.

MODEL No: <b>CON15</b> DESCRIPTION: <b>COIL NAILER</b>
---

Declared vibration emission value in accordance with EN12096
--

Measured vibration emission value - $a$ : 3.3m/s <sup>2</sup>
---

Uncertainty value - $K$ : 3.5m/s <sup>2</sup>
---

Values determined according to EN28622-1
--

You will note that a third value is given in the specification - the highest measured reading in a single plane. This is the maximum level of vibration measured during testing in one of the axes, and this should also be taken into account when making a risk assessment.

'a' values in excess of 2.5 m/s<sup>2</sup> are considered hazardous when used for prolonged periods. A tool with a vibration value of 2.8 m/s<sup>2</sup> may be used for up to 8 hours (cumulative) per day, whereas a tool with a value of 11.2 m/s<sup>2</sup> may be used for ½ hour per day only.

The graph below shows the vibration value against the maximum time the respective tool may be used, per day.

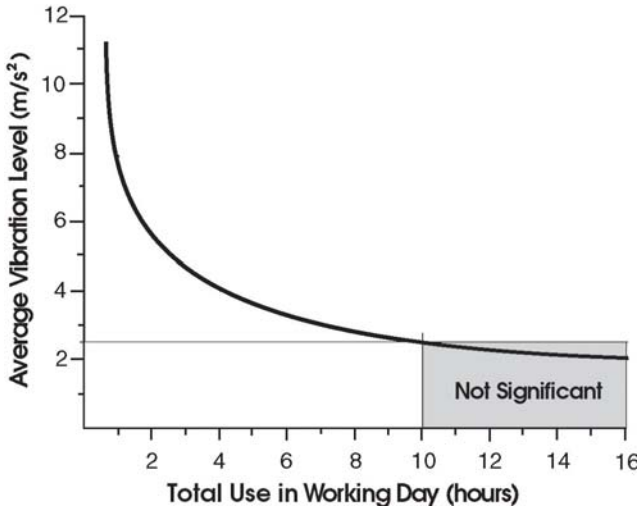

The uncertainty factor should also be taken into account when assessing a risk. The two figures 'a' and 'K' may be added together and the resultant value used to assess the risk.

It should be noted that if a tool is used under abnormal, or unusual conditions, then the vibration level could possibly increase significantly. Users must always take this into account and make their own risk assessment, using the graph above as a reference.

Some tools with a high vibration value, such as impact wrenches, are generally used for a few seconds at a time, therefore the cumulative time may only be in the order of a few minutes per day. Nevertheless, the cumulative effect, particularly when added to that of other hand held power tools that may be used, must always be taken into account when the total daily dose rate is determined.

# DECLARATION OF CONFORMITY



**Clarke**<sup>®</sup>  
**INTERNATIONAL**

Hemnall Street, Epping, Essex CM16 4LG

## DECLARATION OF CONFORMITY

This is an important document and should be retained.

**We hereby declare that this product(s) complies with the following directive(s):**

98/37/EC      *Machinery Directive.*

**The following standards have been applied to the product(s):**

*EN 792-13:2001*

The technical documentation required to demonstrate that the product(s) meet(s) the requirement(s) of the aforementioned directive(s) has been compiled and is available for inspection by the relevant enforcement authorities.

The CE mark was first applied in: 2007

**Product Description:**      Coil Nailer  
**Model number(s):**          CON 15  
**Serial / batch Number:**    N/A  
**Date of Issue:**              26-02-2009

**Signed:**

**J.A. Clarke**  
**Managing Director**

**A SELECTION FROM THE VAST RANGE OF**

**Clarke®**

**QUALITY PRODUCTS**

**AIR COMPRESSORS**

From DIY to industrial, Plus air tools, spray guns and accessories.

**GENERATORS**

Prime duty or emergency standby for business, home and leisure.

**POWER WASHERS**

Hot and cold, electric and engine driven - we have what you need

**WELDERS**

Mig, Arc, Tig and Spot. From DIY to auto/industrial.

**METALWORKING**

Drills, grinders and saws for DIY and professional use.

**WOODWORKING**

Saws, sanders, lathes, mortisers and dust extraction.

**HYDRAULICS**

Cranes, body repair kits, transmission jacks for all types of workshop use.

**WATER PUMPS**

Submersible, electric and engine driven for DIY, agriculture and industry.

**POWERTOOLS**

Angle grinders, cordless drill sets, saws and sanders..

**STARTERS/CHARGERS**

All sizes for car and commercial use.

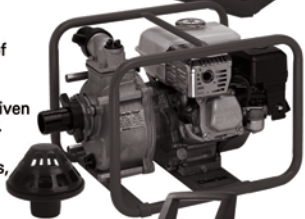

**PARTS & SERVICE: 0208 988 7400**  
E-mail: [Parts@clarkeinternational.com](mailto:Parts@clarkeinternational.com) or [Service@clarkeinternational.com](mailto:Service@clarkeinternational.com)

**SALES: UK 01992 565333 or Export 00 44 (0)1992 565335**

**Clarke** INTERNATIONAL Hemnall Street, Epping, Essex CM16 4LG  
[www.clarkeinternational.com](http://www.clarkeinternational.com)