

A SELECTION FROM THE VAST RANGE OF

ClarkeTM

QUALITY PRODUCTS



AIR COMPRESSORS

From DIY to industrial. Plus air tools, spray guns and accessories.

GENERATORS

Prime duty or emergency standby for business, home and leisure.

POWER WASHERS

Hot and cold, electric and engine driven - we have what you need.

WELDERS

Mig, Arc, Tig and Spot. From DIY to auto/industrial.

METALWORKING

Drills, grinders and saws for DIY and professional use.

WOODWORKING

Saws, sanders, lathes, mortisers and dust extraction.

HYDRAULICS

Cranes, body repair kits, transmission jacks for all types of workshop use.

WATER PUMPS

Submersible, electric and engine driven for DIY, agriculture and industry.

POWER TOOLS

Angle grinders, cordless drill sets, saws and sanders.

STARTER/CHARGERS

All sizes for car & commercial use.



Clarke INTERNATIONAL

For spare parts and servicing, please contact your nearest dealer, or Clarke International on

020 - 8988 - 7400

e-mail: Parts@clarkeinternational.com e-mail: Service@clarkeinternational.com

ClarkeTM

PUMP

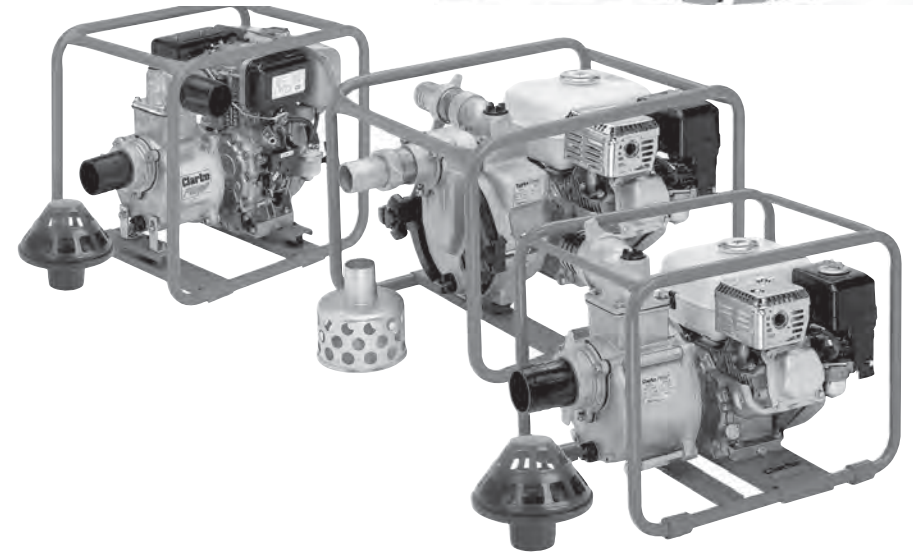

WATER PUMP

Model Nos.
CHF2 & CHF3 • CHS3 & CHS2E • CH3D • CH2D

OPERATING & MAINTENANCE INSTRUCTIONS

CE

0603

For Spare Parts and Service, please contact your nearest dealer,
or CLARKE International, on one of the following numbers.

PARTS & SERVICE TEL: 020 8988 7400

PARTS & SERVICE FAX: 020 8558 3622

or e-mail as follows:

PARTS: Parts@clarkeinternational.com

SERVICE: Service@clarkeinternational.com

This is an important document and should be retained

DECLARATION OF CONFORMITY



We declare that this product complies with the following standards/directives:

- **98/37/EEC**
- **89/336/EEC**
- **EN 292-2**
- **EN 2000/14/EC (ANNEX V)**

Description: **ENGINE DRIVEN WATER PUMP**

Model No:	Measured Sound Power Level	Guaranteed Sound Power Level
CH2E	102 dBL_{WA}	103 dBL_{WA}
CH3D	103 dBL_{WA}	105 dBL_{WA}
CHS2E	103 dBL_{WA}	103 dBL_{WA}
CHS3	103 dBL_{WA}	106 dBL_{WA}
CHF2	103 dBL_{WA}	106 dBL_{WA}
CHF3	108 dBL_{WA}	110 dBL_{WA}

Serial (Batch) No: **See Product Date Plate**

Signed: 

Clarke INTERNATIONAL
Hemnal Street, Epping, Essex CM16 4LG

PARTS DIAGRAM

Model - CHF3

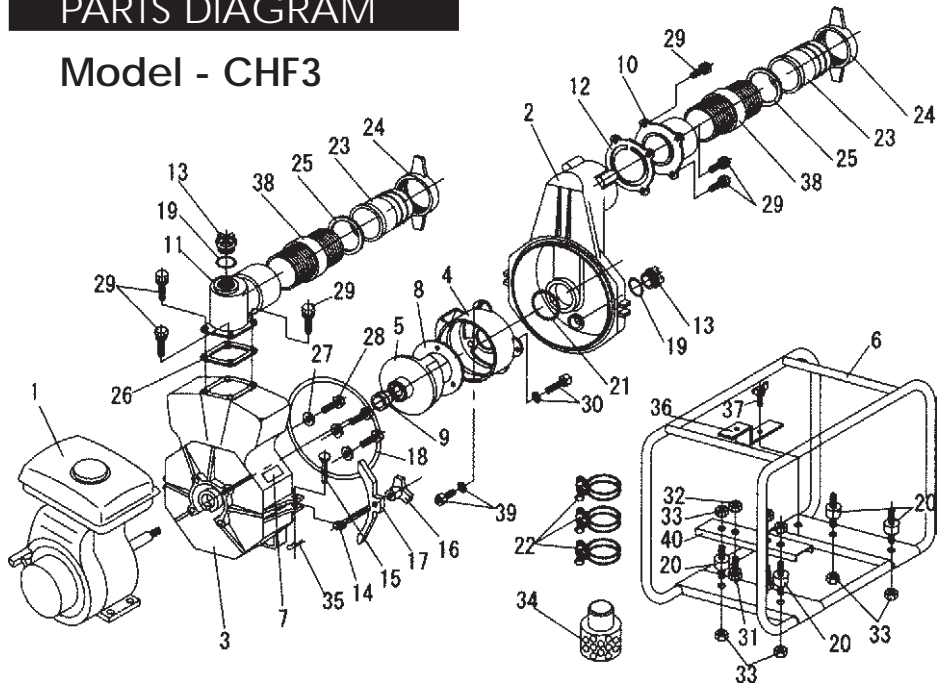

PARTS LIST

For Engine part no. - Consult your CLARKE dealer

No.	Description	Part No.	No.	Description	Part No.
1	Casing	DS821-001N	21	Inner Casing Bkt	DS821-020
2	Casing Cover	DS821-002	22	Hose Clip	DS801-028
4	Inner Casing	DS821-003N	23	Hose Coupling	DS801-018
5	Impeller	DS821-004	24	Coupling Handle	DS801-016
6	Frame	DS821-005-	25	Coupling Packing	DS801-017
7	Name Plate		26	Delivery Packng	DS801-020
8	Liner	DS821-007N	27	Seal Packing	DS501-006
9	Mechanical Seal	DS821-008	28	Bolt M8x48	DS521-027
10	Flange	DS821-009N	29	Bolt M10x30	DS501-003
11	Bend	DS821-010N	30	Blt Hex. Skt. M6x20	DS821-029
12	Check Valve	DS821-011N	31	Bolt M10x45	DS821-030
13	Filler Plug	DS801-012	32	Flange Nut	DS1001-025
14	Cover Bolt	DS821-013	33	Spring Nut	DS1001-024
15	Rivet	DS821-014	34	Strainer	DS821-033
16	Knob	DS821-015	35	Spring Pin	DS821-034
17	Casing Cover Hldr	DS821-016	36	Bracket	DS521-035
18	Casing Packing	DS821-017	37	Wing Bolt	DS521-036
19	"O" Ring	DS801-018	39	Coupling	DS831-033
20	Anti-Vibration Rubber	DS821-019	40	Hex Skt Hd. Bolt	DS821-039

Clarke
INTERNATIONAL

Thank you for purchasing this Clarke Water Pump, designed for pumping water, or water containing sand, or solids in suspension, depending upon the model (please see below).

Please read this leaflet thoroughly and follow the instructions carefully, in doing so you will ensure the safety of yourself and that of others around you, and with correct handling and servicing, you can look forward to the pump giving you long and satisfactory service.

GUARANTEE

This CLARKE product is guaranteed against faulty manufacture for a period of 12 months from the date of purchase. Please keep your receipt which will be required as proof of purchase. This guarantee is invalid if the product is found to have been abused or tampered with in any way, or not used for the purpose for which it was intended.

Faulty goods should be returned to their place of purchase. No product can be returned to us without prior permission. This guarantee does not effect your statutory rights.

SPECIFICATIONS

Model No.	CH2E	CH3D	CHS2E	CHS3	CHF2	CHF3
Hose Dia.	2"	3"	2"	3"	2"	3"
Motor HP	4.0	5.5	4.0	5.5	5.5	8.0
Max Flow	600 L/m	925 L/m	700 L/m	1000 L/m	750 L/m	1300 L/m
Max Head	26M	30M	23M	23M	27M	28M
Max Suction Height	7.5M	7.5M	7.5M	7.5M	7.5M	7.5M
Weight kg	21.5	27	21	26	33	57
Dimensions	470x355x350	456x370x370	429x368x344	500x400x396	510x440x397	660x484x572
Max Size of Solids in Suspension	-	-	20mm	20mm	31mm	31mm
Part No.	7140520	7140610	7230150	7230110	7230120	7230125

Clarke

PUMP

PUMP

Clarke

SAFETY PRECAUTIONS

WARNING

As with all machinery, there are certain hazards involved with their operation and use. Exercising respect and caution will considerably lessen the risk of personal injury. However, if normal safety precautions are overlooked, or ignored, personal injury to the operator, or damage to property may result.

1. These pumps are designed to pump **WATER ONLY**. Never use for pumping petrol (or other flammable liquids), or chemicals.
2. Before operating this pump and its' power unit, you should thoroughly familiarise yourself with all aspects of its' operation, and follow all instructions in this manual and any other supplementary instructions supplied with the pump.
3. Never operate an engine driven unit in an explosive atmosphere, near combustible materials, or where there is insufficient ventilation.
4. Always ensure that the pump is properly secured and anchored where necessary to prevent it from moving during operation, and that the immediate area surrounding the pump is kept clear.
5. Do not over tighten drain or filler plugs. Excessive force may damage the threads or the pump body.
6. Observe all safety precautions for the handling of fuel. Never refuel the engine whilst it is running, and allow the engine to cool sufficiently before refuelling.
7. Whenever carrying out maintenance or making adjustments, ensure that the power unit cannot be started inadvertently.
8. Use at least 1ft (300mm) of flexible hose to make plumbing connections to the pump. Rigid piping may put stress on the pump, causing damage. If rigid piping must be used, it should be supported so as to eliminate stress on the pump.
9. Use only replacement parts supplied by the manufacturer. The use of non standard parts could be hazardous.
10. NEVER run the pump dry. Always fill the pump body with water before starting. When in regular use, it is not necessary to drain the pump body each time it is used, unless there is danger of freezing
11. ALWAYS use the strainer connected to the suction hose, to prevent stones and other solids from being drawn up, which could cause severe damage.

PARTS DIAGRAM

Model - CHF2

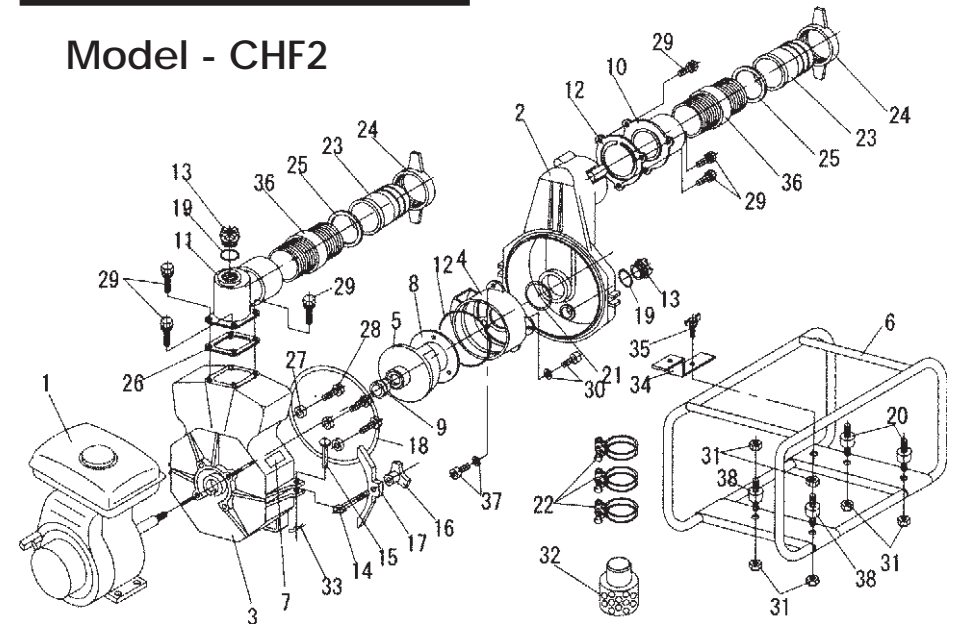

PARTS LIST

For Engine part no. - Consult your CLARKE dealer

No.	Description	Part No.	No.	Description	Part No.
1	Casing	DS521-001N	21	Inner Casing Bkt	DS521-020
2	Casing Cover	DS521-002	22	Hose Clip	DS501-028
4	Inner Casing	DS521-003N	23	Hose Coupling	DS501-08P
5	Impeller	DS521-04	24	Coupling Handle	DS501-016
6	Frame	DS521-005-	25	Coupling Packing	DS501-017
7	Name Plate		26	Delivery Packing	DS501-020
8	Liner	DS521-007N	27	Seal Packing	DS501-006
9	Mechanical Seal	DS521-008	28	Bolt M8x48	DS521-027
10	Flange	DS521-009N	29	Bolt M8x25	DS501-014
11	Bend	DS521-010N	30	Blt Hex. Skt. M8	DS521-029
12	Check Valve	DS521-011N	33	Spring Nut	DS1001-024
13	Filler Plug	DS501-021	34	Strainer	DS521-033
14	Cover Bolt	DS521-013	35	Spring Pin	DS521-034
15	Rivet	DS521-014	36	Bracket	DS521-035
16	Knob	DS521-015	37	Wing Bolt	DS521-036
17	Casing Cover Hldr	DS521-016	39	Coupling	DS531-030
18	Casing Packing	DS521-017	40	Hex Skt Hd. Bolt	DS521-039
19	"O" Ring	DS501-022	41	Anti-Vibration Rubber	DS521-037
20	Anti-Vibration Rubber	DS521-019			

PARTS DIAGRAM

Models - CHS2 & CHS3

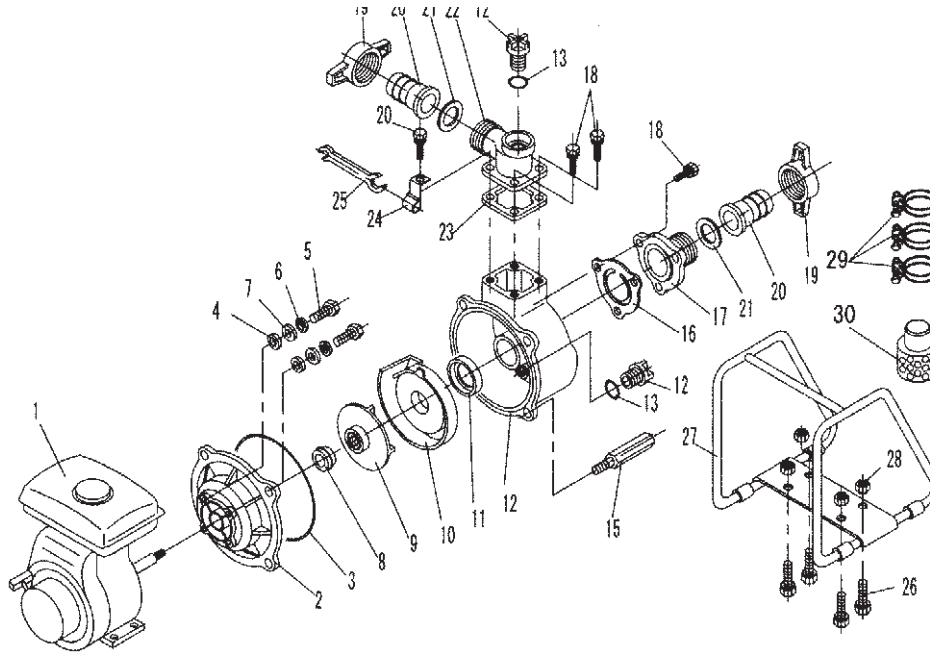

PARTS LIST

For Engine part no. - Consult your CLARKE dealer

No.	Description	Part No. CHS2	Part No. CHS3	No.	Description	Part No. CHS2	Part No. CHS3
1	Motor	Consult your dealer		16	Bolt M8x30	DS501-014	DS801-014
2	Casing Cover	DS501-004	DS501-004		Bolt M8x25	DS501-014	DS801-014
3	Packing Casing	DS501-002	DS501-002	17	Coupling Handle	DS501-016	DS801-016P
4	Seal Packing	DS501-006	DS501-006	18	Hose Coupling	DS501-018P	DS801-018P
5	Bolt M8x48	DS521-027	DS521-027	19	Coupling Pkg	DS501-017	DS801-017
6	Mech Seal	DS521-008	DS521-008	20	Bend	DS501-019	DS801-019
7	Impeller	DS571-009	DS871-009	21	Packing	DS501-020	DS801-020
8	Inner Casing	DS571-011	DS871-011	22	Hook	DS571-021	DS571-021
9	Packing	DS501-012	DS801-012	23	Spanner	DS571-022	DS571-022
10	Casing	DS501-001	DS801-001	24	Bolt M8x40	DS501-023	DS501-023
11	"O" Ring	DS501-022	DS501-022	25	Frame	DS571-030	DS871-030
12	Filler Plug	DS501-021	DS501-021	26	Flange Nut	DS501-024	DS501-024
13	Spacial Bolt	DS571-003	DS571-003	27	Hose Clip	DS501-028	DS801-028
14	Check Valve	DS501-015	DS801-015	28	Strainer	DS571-029	DS871-029
15	Valve Case	DS501-013	DS801-013				

Clarke

PUMP

INTRODUCTION

These self-priming centrifugal pumps are designed for pumping water, or water containing small solids in suspension. The pumps are self-priming, and an open impeller with small solids handling capacity is fitted (see specifications). The suction strainer supplied, must always be used, to ensure that large stones or other objects cannot be drawn up, as this would cause severe damage to the pump.

Models CH2E and CH3D should be used for **water only**, Models CHS2E and CHS3 are **semi-trash** pumps, and may be used for contaminated water. Models CHF2 and CHF3, are **trash pumps**, for use with heavily contaminated water.

REMEMBER: Contaminated water is water containing small solids in suspension, NOT slurry, sludge, sand, or mud.

This illustration shows a CH3D pump, but all pumps are similar in construction.

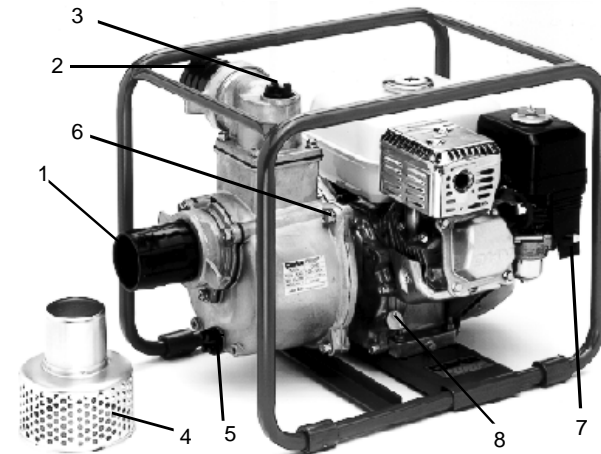

1. Input to Suction Chamber
2. Output or Discharge pipe
3. Filler Plug
4. Strainer
5. Drain Plug
6. Suction Chamber Bolts
7. Starter Recoil Rope
8. Oil Filler and Dipstick

PUMP

Clarke

PREPARING THE PUMP FOR OPERATION

A. GENERAL.

Always prepare the site beforehand.

Ensure there is an adequate, firm foundation on which the pump may be located, and as near the water source as possible.

Ensure there is adequate drainage for the discharged water, and that there is no danger of damage to property as a result of the pumping operation.

B. THE ENGINE.

WARNING:

Never run the engine in an enclosed space
- ensure there is adequate ventilation.

This pump is not supplied with engine oil or fuel. Fill the engine crankcase with oil as specified in the engine manual.

Fill the fuel tank with petrol.

Consult the engine manual and carry out all checks, and prepare for use as specified.

C. THE PUMP

1. Place the pump on a firm, level foundation, putting it as near as possible to the water source, and ensure it is anchored where necessary, to prevent it from moving during operation.
2. Connect the suction hose to the pump housing, and ensure the complete hose is sound. There must be no damage of any kind. The connection at the pump body, and all other connections, (should there be any), **must be air tight**.

Hoses or pipes should be supported independently and not carried by the pump.

IMPORTANT : An air leak in the suction line will prevent priming, and reduce the capacity of the pump. The vast majority of problems which may occur, are as a result of air leaks in the suction line.

Pay particular attention to the following:

- a. Use sealant on all threaded connections.
- b. Always ensure the quick release gasket is in place, and correctly fitted.
- c. Always use a flexible hose at the pump body connection, of at least 1ft (300mm).
- d. Keep all pipes/hoses as short and straight as possible, and avoid sharp bends.
- e. If a flexible hose must be laid across a roadway, protect it with planking. (Instantaneous shut off pressure, applied when a vehicle runs across an unprotected hose, will cause "hydraulic shock", which can damage the pump and/or the hose).

PARTS DIAGRAM

Model - CH3D

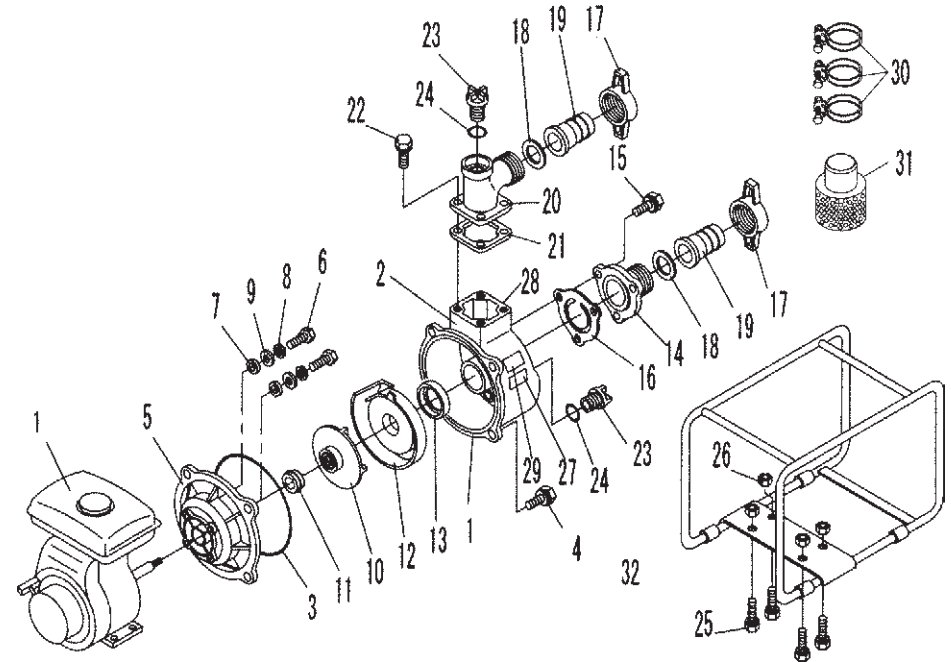

PARTS LIST

For Engine part no. - Consult your CLARKE dealer

No.	Description	Part No.	No.	Description	Part No.
1	Casing	DS803-001	19	Bend	DS801-019
2	Packing	DS501-002	20	Packing Bend	DS801-020
3	Bolt M10x30	DS501-003	21	Bolt W/S W&W	DS501-014
4	Casing Cover	DS501-004	22	Filler Plug	DS501-021
5	Bolt M8x48	DS501-005	23	Packing	DS501-022
6	Seal Packing	DS501-006	24	Drain Plug	DS501-021
7	Spring Washer	DS501-007	25	Packing	DS501-022
8	Washer	DS501-008	26	Hose Joint	DS501-022
9	Impeller	DS801-009	27	Packing	DS501-021
10	Mechanical Seal	DS501-010	28	Hose Coupling	DS801-018
11	Inner Casing	DS801-011	29	Bolt W/S W	DS501-230
12	Packing	DS801-012	30	Flange Nut M8	DS501-024
13	Valve case	DS801-013	31	Name Plate	DS501-025
14	Bolt M8x30	DS801-014	32	Caution Plate	DS501-026
15	Check Valve	DS801-015	33	Capacity Plate	DS801-027
16	Hose Joint	DS801-016	34	Hose Clip	DS801-028
17	Packing coupling	DS801-017	35	Strainer	DS801-029
18	Hose Coupling	DS801-018	36	Frame	DS801-030

PARTS DIAGRAM

MODEL - CH2E

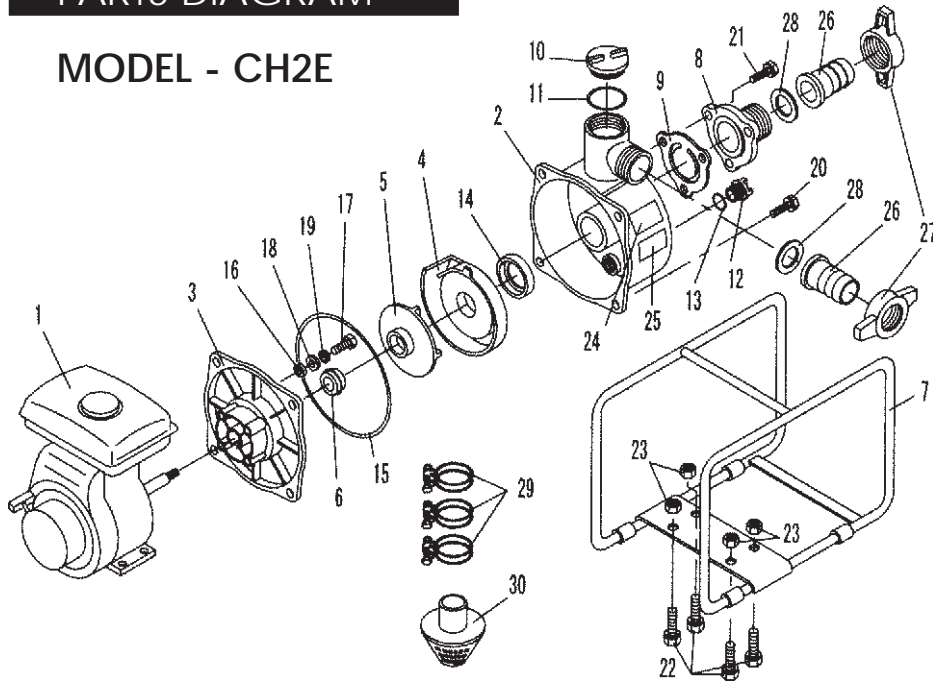

PARTS LIST

For Engine part no. - Consult your CLARKE dealer

No.	Description	Part No.	No.	Description	Part No.
1	Engine	-	16	Seal Packing	DS501-006
2	Casing	DS505-001	17	Bolt M8x48	DS501-005
3	Casing Cover	DS505-004	18	Plain Washer	DS501-008
4	Inner Casing	DS505-011	19	Spring Washer	DS501-007
5	Impeller	DS505-009	20	Tapping Bolt 30M	DS505-050
6	Mechanical Seal	DS505-010	21	Tapping Bolt 25M	DS523-051
7	Frame	DS505-030	22	Bolt M8x40	DS501-023
8	Valve Case	DS505-013	23	Nut M8	DS501-024
9	Check Valve	DS505-015	24	Data Plate	
10	Filler Plug	DS505-021	25	Name Plate	
11	Packing	DS505-022	26	Hose Coupling	7950320
12	Drain Plug	DS501-021	27	Coupling Handle	7950320
13	Packing	DS501-022	28	Coupling Packing	7950320
14	Packing	DS501-012	29	Hose Clip	DS501-028
15	Packing	DS505-002	30	Strainer	DS505-029

- The suction strainer **MUST** be attached to the end of suction hose, to prevent large stones etc., from being drawn up which could cause severe damage. Keep the strainer clean. If it is likely to clog with dirt or debris, proceed as follows:
 - Prepare a bed of stones on which to rest the strainer.
 - Tie the strainer so that it stays off the bottom of the pit, pond or excavation.
 - Tie the strainer inside a basket or bucket.
- Remove the Filler Plug on top of the pump case and fill the pump with water, leaving no air gap. Remember the pump is self-priming only when the pump is filled. It will prime and reprime itself without refilling. Refilling is necessary only if the pump has been drained or if the water has been lost. Never run the pump dry.
- Ensuring there is adequate drainage for the discharged water, attach the discharge hose if required, ensuring it is well protected and supported.

If the discharge line runs vertically more than 30ft., it is advisable to install a check valve in the discharge line near the pump to stop destructive liquid hammer when the pump is shut down. If a check valve is installed, it may also be necessary to vent the top of the pump so that air can be expelled during automatic repriming. This air bleed may be accomplished by providing a 1/4" line from the top of the pump back to the liquid source. We will not assume any responsibility for damage to the pump if no check valve is used in the discharge line.

Properly fuelled and lubricated, your pump will run without attention.

OPERATION (Refer to the illustration on page 3)

Ensure the site and pump is prepared as detailed on page 4, then proceed as follows:

1. STARTING.

Refer to the Engine Manual. Pay particular attention to "running in" the engine. Do not exceed the recommended engine speeds or running duration.

- With the fuel cock open, pull the starter recoil rope slowly two or three times, to allow fuel to reach the carburettor.
- Hold down the pump, and with the ignition switch ON, and choke and throttle, set according to the engine manual, pull the starter recoil rope firmly until the engine starts. Do not snatch at the starter rope, and allow it to retract slowly after each pull.
- Once the engine starts, set the choke according to the manual, and use the engine throttle to gradually increase engine speed.

2. PRIMING TIME.

With a suction lift from 5 to 10ft., the pump should discharge liquid in less than a minute. A suction lift of 25ft (at sea level) should require not more than 2 minutes for initial prime. To further reduce priming time the engine speed may be increased, after the engine is properly run in. If pumping does not start within this time, shut off engine and check carefully to find the problem, (See TROUBLESHOOTING GUIDE).

NOTE: Filling the suction pipe with water will speed up the priming process, and it is recommended that a foot valve (non-return valve) be fitted to the end of the suction pipe.

3. CONTROL.

On high suction lifts, a higher engine speed is necessary than on low lifts. On shallow lifts therefore, or when there is little water to pump, preserve fuel and engine wear, by reducing engine speed. (See engine manual).

4. STOPPING.

4.1 GRADUALLY reduce engine speed to minimum, and stop the engine by switching OFF the ignition switch.

4.2 Close the fuel cock.

5. BLOCKAGES

In the event of blockages, where debris has entered the suction chamber, the suction chamber bolts, (or quick release clamps on the larger pumps), allow the chamber to be opened and cleaned

MAINTENANCE

A. ENGINE

Ensure the engine is maintained in accordance with the instructions given in the engine manual, additionally, if the pump is not to be used for some time, it should be prepared as follows:

1. Drain the fuel tank and carburetor completely.
2. Remove the spark plug, and pour 2 - 3 teaspoons of light oil into the cylinder through the spark plug hole.
3. Pull the starter recoil rope slowly, 2 or 3 times so that the oil is deposited on the cylinder walls, and replace the spark plug.

B. PUMP

Always maintain the pump in a clean condition, checking regularly for loose bolts etc. Additionally, drain the pump body whenever there is danger of freezing, and if the pump has been used with contaminated or salty water, it should be thoroughly flushed with clean water immediately after use, both **inside and out**.

If the pump is not to be used for some time, it should be flushed thoroughly with clean water, and drained completely before storing in a clean dry environment

TROUBLESHOOTING

NOTE: For engine problems, consult the manual supplied.

FAULT	PROBLEM	REMEDY
A) Pump fails to prime	<ol style="list-style-type: none"> 1. Priming chamber not filled correctly. 2. Air leaks through the suction line joints (broken/damaged screws or, rubber hoses, loose or broken hose clamps 3. Quick coupling gaskets broken or not correctly fitted. 4. Suction or delivery line obstructed 5. Pump speed too low. 6. Worn or broken impeller. 7. Air leaks through damaged mechanical seal. 8. Suction strainer clogged 	<ol style="list-style-type: none"> 1. Fill priming chamber leaving no air gap. 2. Carry out repairs as necessary 3. Check connections, and renew gaskets where necessary. 4. Remove obstruction and ensure there are no kinks in delivery line. 5. Increase engine speed. 6. Renew Impeller. 7. Renew Seal. 8. Clean strainer, and ensure it is not submerged in mud or sediment etc.
B) Low output	<ol style="list-style-type: none"> 1. Suction strainer clogged. 2. Suction or delivery line obstructed 3. High friction losses in the suction line. 4. Suction lift too high. 5. Pump speed too low. 6. Impeller clogged. 	<ol style="list-style-type: none"> 1. Clean strainer, and ensure it is not sub merged in mud or sediment etc. 2. Remove obstruction and ensure there are no kinks in delivery line. 3. Avoid unnecessary curves, restrictions or valves. 4. Set pump as near as possible to the level of the liquid to be pumped. 5. Increase engine speed. 6. Disassemble pump, and clean.