

A SELECTION FROM THE VAST RANGE OF

Clarke[®]

QUALITY PRODUCTS

AIR COMPRESSORS

From DIY for industrial. Plus air tools, spray guns and accessories.

GENERATORS

From jobs of emergency standby to outdoor power and lighting.

POWER WASHERS

Hot and cold, electric and engine driven - we have what you need.

WELDERS

MIG, MAG, TIG and more from DIY to professional use.

METALWORKING

Drill, grinders and more for DIY and professional use.

WOODWORKING

Saws, planers, routers, sanders and more for DIY.

HYDRAULICS

Cranes, hoists, rams, etc. Professional grade for all types of construction use.

WATER PUMPS

Submersible, electric and engine driven for DIY, agricultural and industry.

POWER TOOLS

Angle grinders, cordless drill sets, saws and cutters.

STARTER/CHARGERS

All sized for car & commercial use.



Clarke[®] INTERNATIONAL

For spare parts and servicing, please contact your nearest branch or direct: 020-8988-7400

020 - 8988 - 7400

e-mail: Parts@clarkinternational.com e-mail: Service@clarkinternational.com

Clarke[™]

air



BRONCO 2 OIL FREE AIR COMPRESSOR

OPERATION & MAINTENANCE INSTRUCTIONS



Guarantee

This product is guaranteed against faults in manufacture for 12 months from purchase date. Please keep your receipt as proof of purchase.

This guarantee is invalid if the product has been abused or tampered with in any way, or not used for the purpose for which it is intended. The reason for return must be clearly stated.

This guarantee does not affect your statutory rights.

Parts Diagram - Receiver and Components

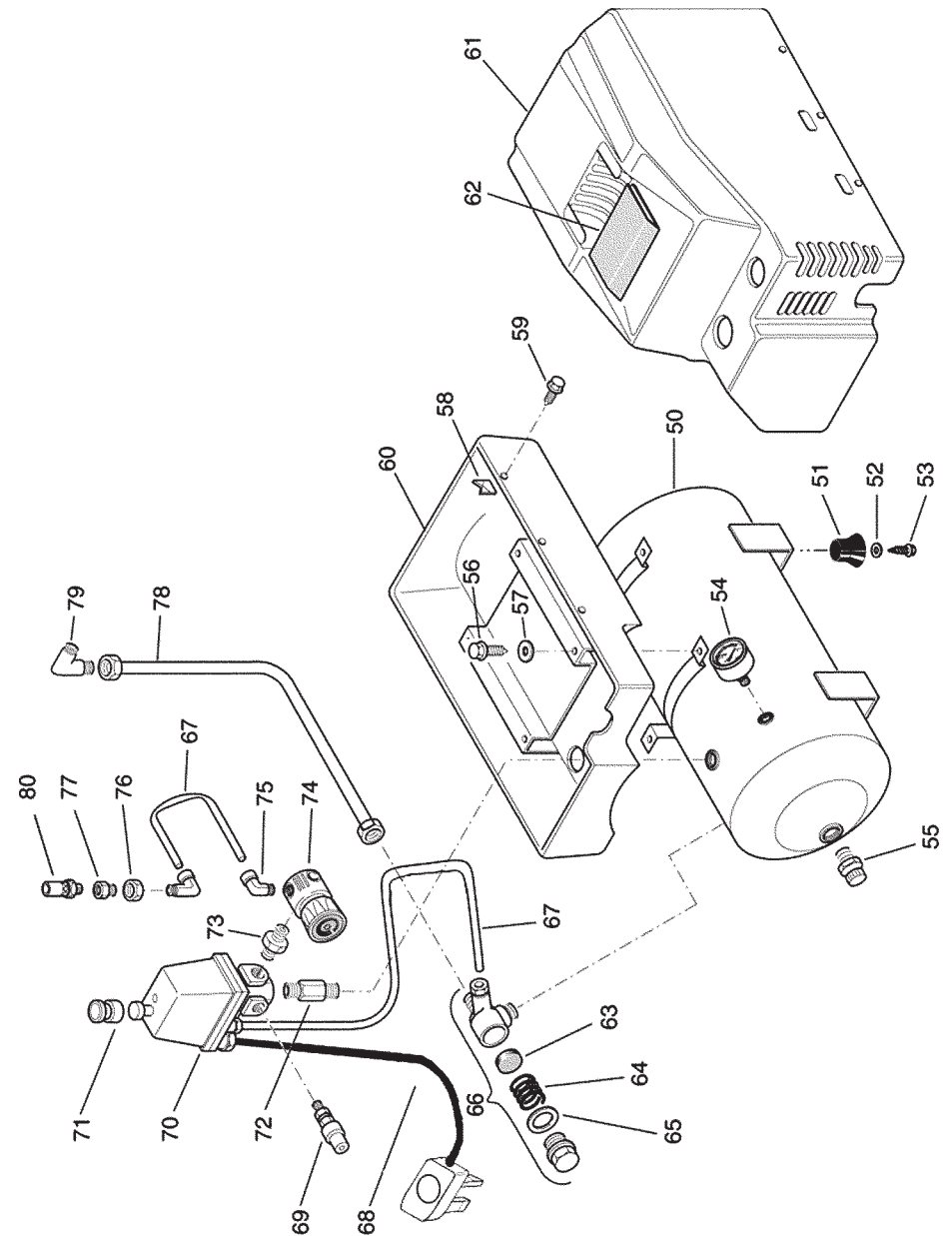

Parts List - Receiver and Components

No.	Description	Qty	Part No
50	Receiver	1	FN126HB0055B
51	Vibration Foot	4	FN199958000
52	Washer	4	FN014005037
53	Screw	4	FN014006044
54	Pressure Gauge	1	FN330006000
55	Drain Cock	1	FN022021000
56	Screw	4	FN014006102
57	Washer	4	FN014005038
58	Plate	4	FN015078000
59	Screw	4	FN014006022
60	Lower Housing	1	FN126HB0027
61	Main Cover	1	FN126HB0003
62	Handle	1	FN126HB0007
63	Seal	1	FN047113001
64	Spring	1	FN04713002
65	'O' Ring	1	FN010041000
66	Non Return valve	1	FN347060000
67	Tubing	1	FN046001000
68	Power Cable	1	FN164A04600
69	Safety Valve	1	FN047057000
70	Pressure Switch	1	FN321051000
72	Fitting	1	FN1996260000
73	Nipple	2	FN011017000
74	Pressure Reducer	1	FN319045000
75	Elbow	2	FN011165000
76	Check Nut	1	FN011337000
77	Reducer	1	FN0112130000
78	Delivery Tube	1	FN126HB0001
79	Elbow	1	FN011285000
80	Coupler	1	FN322053000

BRONCO AIR COMPRESSOR

Thank you for purchasing this Clarke Oil Free Air Compressor. Before attempting to operate the machine, please read this instruction manual thoroughly and carefully follow all directions given. This is for your own safety and that of others around you, and also to help you achieve long and trouble free service from your compressor.

Your Bronco Air Compressor can be used for a variety of applications including spraying paint and other liquids, powering tools, inflating and cleaning where the average air consumption of the equipment being used does not exceed approximately 3.5 cubic feet per minute (3.5CFM).

Unlike many other machines, the Bronco has the advantage of delivering completely oil free air, which can sometimes be so important when performing certain jobs such as air brush work etc.

Contents

Page

Safety Precautions	3
Electrical Connections	4
Operating Instructions	5
Maintenance	6
Fault finding	7
Shutting down the compressor	7
Paint Spraying Hints	8 & 9
Technical data	10
Parts List & Diagrams	11 & 12
Declaration of Conformity	14

SAFETY PRECAUTIONS



As with all machinery, there are certain hazards involved with their operation and use. Exercising respect and caution will considerably lessen the risk of personal injury. However, if normal safety precautions are overlooked, or ignored, personal injury to the operator, or damage to property may result. It is in your own interest to read and pay attention to the following rules:

1. COMPRESSED AIR CAN BE DANGEROUS, **NEVER** direct a jet of air at people or animals, and **NEVER** discharge compressed air against the skin.
2. **ALWAYS** adjust the pressure regulator to the recommended setting for the particular spray gun or tool being used.
3. **ALWAYS** protect yourself. Think carefully about any potential hazards which may be created by using the air compressor and use the appropriate protection. e.g. Goggles will protect your eyes from flying particles. Face masks will protect you against paint spray and/or fumes.
4. **ALWAYS**, when spraying inflammable materials e.g. cellulose paint, ensure that there is adequate ventilation and keep clear of any possible source of ignition.
5. **ALWAYS** ensure that all individuals using the compressor have read and fully understand the Operating Instructions supplied.
6. **ALWAYS** ensure that any equipment or tool used in conjunction with your compressor, has a safety working pressure exceeding that of the machine.
7. **ALWAYS** make sure that children and animals are kept well away from the compressor and any equipment attached to it.
8. **ALWAYS**, before spraying any material always consult paint manufacturers instructions for safety and usage.
9. **ALWAYS**, when disconnecting air hoses or other equipment from your compressor ensure that the air supply is turned off at the machine outlet and expel all pressurised air from within the machine and other equipment attached to it.
10. **DO NOT** adjust, or tamper with the safety valves. The maximum pressure is factory set, and clearly marked on the machine.
11. **DO NOT** leave pressure in the receiver overnight, or when transporting.
12. **DO NOT** operate your compressor with any guards removed.
13. **DO NOT** exert any strain on electrical cables and ensure that air hoses are not tangled or wrapped around machinery etc.
14. **DO NOT** operate in wet or damp conditions. Keep the machine dry at all times. Similarly, a clean atmosphere will ensure efficient operation. Do not use in dusty or otherwise dirty locations.
15. Some of the metal parts can become quite hot during operation. Take care not to touch these until the machine has cooled down.
16. Before carrying out any maintenance, ensure the pressure is expelled from the air receiver, and the machine is disconnected from the mains supply.
17. Electrical or mechanical repairs should only be carried out by a qualified engineer. If problems occur, contact your Clarke dealer.

Additionally, please keep these instructions in a safe place for future reference.

Parts Diagram - Pump

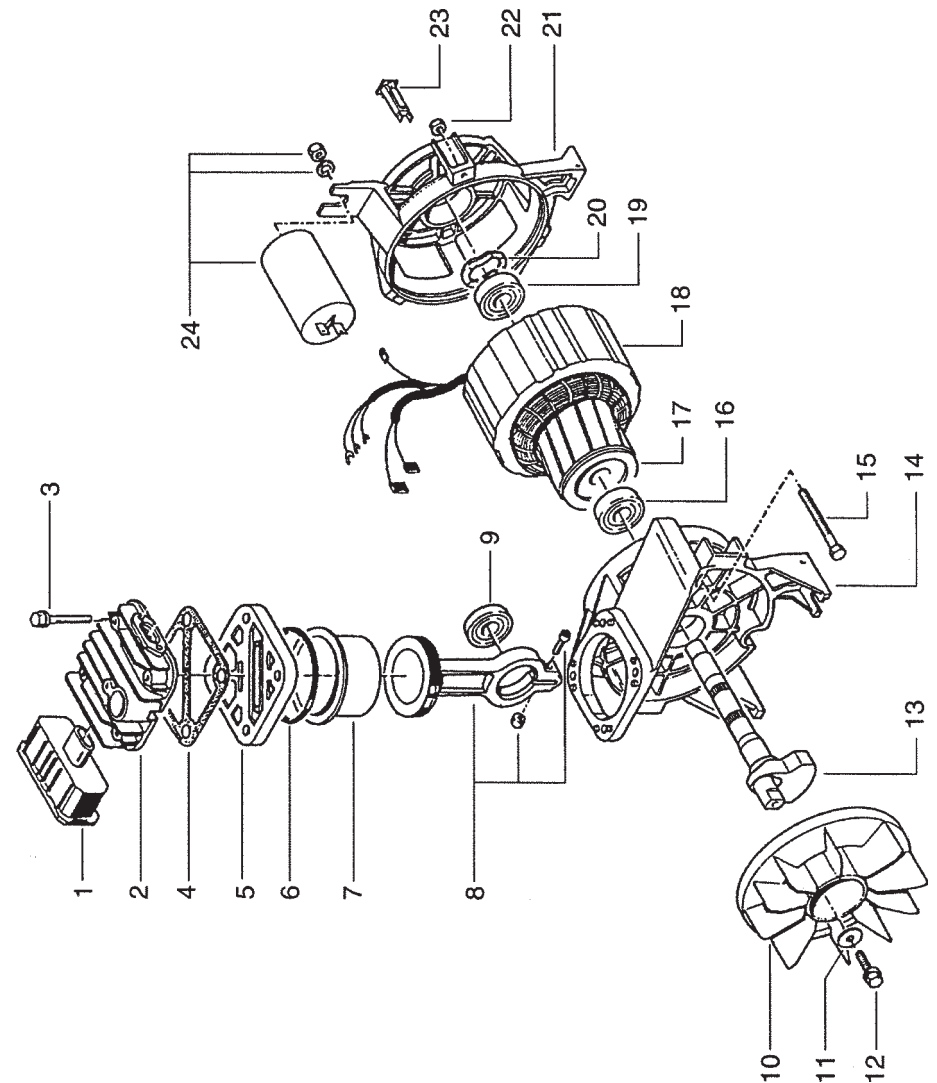

Parts List - Pump

No.	Description	Qty	Part No
1	Intake Filter	1	FN317028000
2	Head	1	FN1160060031
3	Screw	4	FN014013027
4	Head Gasket	1	FN115005017
5	Valve Plate	1	FN416005009
6	'O' Ring	1	FN010057000
7	Cylinder	1	FN016005007
8	Con-Rod Assy	1	FN416005003
9	Bearing	1	FN033059000
10	Impeller	1	FN116010004
11	Washer	1	FN116010013
12	Screw	1	FN014001022
13	Crankshaft	1	FN116010006
14	Casing	1	FN015010025
15	Screw	3	FN014002122
16	Bearing	1	FN033028000
17	Armature	1	FN034128000
18	Stator	1	FN316008604
19	Bearing	1	FN033070000
20	Balancing Ring	1	FN027011000
21	Rear Frame	1	FN116010016
22	Nut	3	FN014004001
23	Overload Reset	1	FN008040000
24	Capacitor	1	FN009200004

Electrical Connections

This product is provided with a standard 13 amp, 230 volt (50Hz), BS 1363 plug, for connection to a standard, domestic electrical supply. Should the plug need changing at any time, ensure that a plug of identical specification is used.

⚠ WARNING! THIS APPLIANCE MUST BE EARTHED ⚠

Should the plug need changing at any time, ensure that a plug of identical specification is used. **IMPORTANT:** The wires in the mains lead should be wired up in accordance with the following colour code:

Green & Yellow Earth

Blue Neutral

Brown Live

- Connect the **Green & Yellow** coloured cord to the plug terminal marked a letter "E" or marked with the symbol "⏏"
- Connect the **BLUE** coloured cord to the plug terminal marked a letter "N"
- Connect the **BROWN** coloured cord to the plug terminal marked a letter "L"

If this appliance is fitted with a plug which is moulded on to the electric cable (i.e. non-rewireable) please note:

1. The plug must be thrown away if it is cut from the electric cable. There is a danger of electric shock if it is subsequently inserted into a socket outlet.
2. Never use the plug without the fuse cover fitted.
3. Should you wish to replace a detachable fuse carrier, ensure that the correct replacement is used (as indicated by marking or colour code).
4. Replacement fuse covers can be obtained from your local Clarke dealer or most electrical stockists.

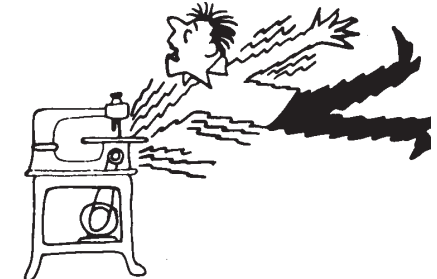

FUSE RATING

The fuse in the plug must be replaced with one of the same rating (**13amps**) and this replacement must be ASTA approved to BS1362.

We recommend that this machine is connected to the mains supply via a Residual Current Device (RCD)

If in doubt, consult a qualified electrician. Do not attempt any electrical repairs yourself.

CABLE EXTENSION.

Always use an approved cable extension suitable for the power rating of this tool (see specifications), the conductor size should also be at least the same size as that on the machine, or larger. When using a cable reel, always unwind the cable completely.

Operation

Before connecting your Bronco to the mains supply, check the following :-

1. Ensure the STOP/START switch is in the STOP position (UP for START and Down for STOP).
2. The pressure regulator should be set to its lowest setting e.g. turned fully anti clockwise.
3. Check that the air receiver drain valve is fully CLOSED, (finger tight only).

Now connect your air hose to the air outlet.

NOTE: A quick fit nut is supplied. Corresponding couplings are available from your CLARKE dealer. Alternatively, the quick fit nut may be unscrewed and replaced by a standard type straight hose connector. The hose may then be attached using a hose clip.

Attach the hose to the air tool...screwing it on directly. DO NOT use a quick fit coupling at the air tool.

Once the hose connections are complete, plug in and start the compressor by pulling the STOP/START switch upwards.

The compressor will start and pressure will build up in the receiver to a predetermined maximum 116 PSI/8bar, when it will then stop.

At this point, slowly turn the pressure regulator clockwise to reach the desired setting. Remember, the air gauge registers the receiver pressure, NOT the outlet pressure.

Checks should now be made to ensure there are no air leaks. Should leaks be apparent, they should be rectified before continuing.

Operate the spray gun or air tool in the normal way.

The air compressor will restart when the pressure has fallen by approximately 20 PSI and this automatic STOP/START process will then continue as necessary to replenish the receiver.

When you have finished the job in hand, always switch OFF at the STOP/START switch on the machine, NEVER by switching OFF at the mains.

ALWAYS turn the pressure regulator fully anticlockwise when you have finished with the compressor, and operate the trigger on the air tool BEFORE disconnecting the air hose.

NEVER attempt to disconnect the air hose before checking to ensure there is no air at the air tool.

To quickly drain the air receiver, pull and hold the ring pull on the Pressure Relief Valve

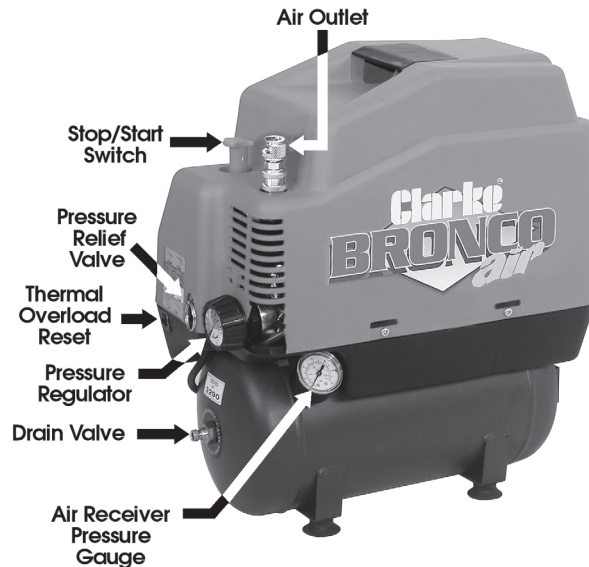

Technical Data

Model	Bronco
Maximum Air Pressure	8 BAR - 116 PSI
Air Displacement	7 CFM (200 lpm)
Motor	1½ HP (1.1kW)
Voltage	230 VAC 50Hz 1pH
Rotation	2850RPM
Sound Power Level	95dB _{LWA} (Guaranteed)
Gross Weight	15.5 kg
Receiver Capacity	6 Litre
Part Number	2220041
Dimensions (mm)	375 x 200 x 435mm

Please note that the details and specifications contained herein are correct at the time of going to print. However CLARKE International reserve the right to change specifications at any time without prior notice. Always consult the machines data plate

Accessories

Your Bronco Air Compressor can be used in conjunction with a range of optional accessories, for inflating tyres, air brushing, stapling blowing and many other uses, For further details, please contact your nearest dealer.

Clarke
INTERNATIONAL

Paint Spraying Hints

PAINT THINNING

For a professional looking finish paint must be thinned. If manufacturers recommendations on thinning are not available, the following can be used as a general guide.

Water based paints (emulsions) 10-20% water.
Oil based paints (gloss) up to 10% thinners.
Cellulose paints up to 50 % cellulose thinners.

HANDLING THE GUN

the first requirement for a good resultant finish is the proper handling of the gun. The gun should be perpendicular to the surface being covered and moved parallel with it. The stroke should be started before the trigger is pulled and likewise, released before the stroke is ended. This gives accurate control of the gun and material.

The distance between the gun and the surface to be covered should be 6 to 12 inches depending on the material and atomising pressure. The material deposited should always be even and wet. Lap each stroke over the preceding stroke to obtain a uniform finish.

NOTE: To reduce overspray and obtain maximum efficiency, always spray with the lowest possible atomising air pressure.

Best results are achieved by a good constant motion. Start motion before pressing trigger. Follow through motion before releasing trigger

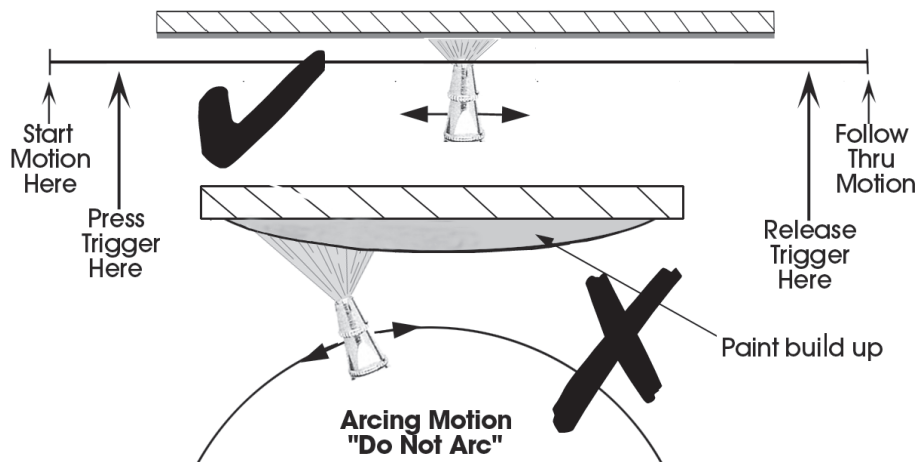

Drain Valve

After a period of use, especially if the weather has been warm and humid, it is quite possible that water (condensate), will have accumulated in the receiver.

To remove this condensate, first switch OFF the Bronco after ensuring that there is at least some compressed air in the receiver.

Hold the whole machine securely and raise one end so that the drain valve assumes the lowest position. Now simply loosen the drain valve for a few moments allowing the air and any water to escape.

Re-tighten the drain valve and return the Bronco to its normal position.

Thermal Overload

Should the machine overheat, the thermal overload will intervene. Wait for at least 5 minutes before pressing the reset button, indicated in the illustration opposite.

NOTE: The reset will not operate until the machine has cooled sufficiently

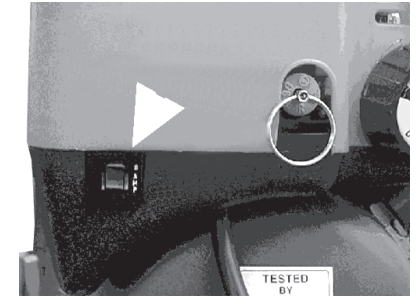

Maintenance

It is important to keep the Bronco Air Compressor clean, this can be carried out using a small soft brush and a vacuum cleaner.

In particular the air filter should be inspected periodically, so that it is always kept clean. If this instruction is not adhered to, a loss of performance could occur, even worse, any dirt passing through the filter could make its way into the cylinder head and adversely affect the valves. This could lead to more extensive damage necessitating its dismantling and replacement parts etc.

Before carrying out any service work, **ALWAYS** disconnect the Bronco from the mains supply. If necessary allow the machine to cool down first. When ready to start, proceed as follows:-

1. Release any air remaining in the tank by loosening the drain valve slightly.
2. Remove the six cover retaining screws, and lift off the cover to reveal the pump and motor.
3. Clean the air intake filter, to do this :-
 - a) Carefully prise off the plastic end cover and remove the sponge element from inside.
 - b) Clean the inner housing, using a soft brush.
 - c) The sponge may be gently washed in warm soapy water, rinsed and allowed to dry thoroughly before refitting.
 - d) Refit the plastic end cover, ensuring it is clipped back into its original position.
 - e) Carefully refit main cover and secure in place using the six screws removed previously.

Note : If any part of the filter is damaged, you should obtain replacement parts from your CLARKE dealer.

Caution

Do not attempt any repairs or adjustments if you are uncertain as how it should be done. If you have any queries, please contact your nearest CLARKE dealer, or otherwise telephone CLARKE International, Service Department, on: 020 8988 7400).

Shutting Down The Compressor

1. Ensure that the ON/OFF switch is in the off 'O' position.
NEVER USE THE MAINS SWITCH TO STOP THE MOTOR.
2. Depress equipment trigger (spray gun) to release air from the hose and compressor before disconnecting from the machine.
3. Switch off and remove mains.

Fault Finding

With considerate use, your CLARKE Air Compressor should provide you with long and trouble free service. Routine checks should be made on both the electrical supply as well as the compressed air lines and connections. If any fault appears, the reason for which is not immediately obvious, please contact your local CLARKE Dealer.

PROBLEM	PROBABLE CAUSE	REMEDY
The compressor stops and will not start again.	Bad connections.	Check electrical connections. Clean and tighten as necessary.
	Thermal Overload has intervened.	Switch off and wait at least 5 minutes before pressing the reset button.
	Motor windings burnt out.	Contact your local dealer for a replacement motor.
The compressor does not reach the set pressure and overheats easily.	Compressor head gasket blown or valve broken.	Contact your CLARKE dealer. Replace Piston (contact your CLARKE dealer)

Clarke[™]
INTERNATIONAL

Paint Spraying Hints

WARNING

NEVER attempt to spray unless you are wearing suitable, approved respiratory and eye protection.

REMEMBER that some modern paints require specialist respiratory protection...always consult the paint manufacturers instructions.

1. GENERAL PREPARATION

- a. Ensure that the area in which you will be spraying is clean and dust free.
- b. Connect spray gun to compressor via suitable flexible hose.
- c. With no paint in spray gun, test system for air leaks.
- d. Cover adjacent pieces of equipment to prevent overspray. Mask areas of the article not to be sprayed.
- e. Ensure surface to be painted is clean, dry and free from oil and dust. Check paint manufacturer's instructions for any special surface preparation required.

REMEMBER - TIME SPENT PREPARING SAVES TIME SPENT FINISHING

2. PAINT PREPARATION

- a. Achieve the correct paint viscosity. This should be done according to paint manufacturer's instructions, and will vary according to type of paint.
- b. Having mixed the paint thoroughly in a separate container, pour into the spray gun paint container through a fine filter.

DO NOT OVERFILL SPRAY GUN PAINT CONTAINER - three quarters full is maximum.

- c. It is usually best to experiment with a couple of practice spray coats on a piece of material with the same type of surface as the article you wish to spray, eg. metal for a car body panel, wood for a piece of furniture etc.
- d. Some common problems:

PROBLEM	CAUSE	CORRECTION
Paint does not atomise (comes out in blobs)	Paint is too thick, air pressure is too low.	Add thinners. Increase air press. (not above 50 psi, unless specified by paint manuf.)
Paint dries before hitting surface, leaving it dry with a rough texture	Paint is too thin. Air pressure is too high	Add more paint. Reduce air pressure
Finish is pitted like Orange peel to work	Air pressure too high or spraying too close gun and work.	Reduce air pressure, increase distance between