

Clarke[®] weld



CE

ARC WELDERS

1206

PARTS LISTS & DIAGRAMS



SPECIFICATIONS

Model No.	105N	115N	160N	190N
Min/Max (Amps)	40-100	30-110	40-150	50-185
Electrode Dia.	1.6-2.5mm	1.6-2.5mm	1.6-3.25mm	1.6-3.25mm
Open Circuit Volts	38-47	44.5-47	45-48	45-48
Volts/Phase	230V, 1Ph	230V, 1Ph	230V, 1Ph	230V, 1Ph
Max Input kW	2.5	2.5	2.8	4.0
Dimensions (mm)	440x232x300	440x235x300	440x235x300	440x235x300
Weight (kg)	12.5	14.5	15.6	18.5
Part No.	6010972	6010974	6010976	6010978

Model No.	145TN	165TN	190TE	145ND
Min/Max (Amps)	40-140	45-160	35-180	40-140
Electrode Dia.	1.6-3.25mm	1.6-4.0mm	1.6-4.00mm	1.6-3.25mm
Open Circuit Volts	45-48	45-48	48	45-48
Volts/Phase	230V, 1ph	230/400, 1Ph	230/400, 1Ph	230/115, 1Ph
Max Input kW	3.5	4.0	4.5	3.5
Dimensions (mm)	400x250x300	500x260x340	500x260x340	370x250x370
Weight (kg)	19	24	25	18
Part No.	6010605	6010610	6010740	6010600

Model No.	235TE	260TE	300TE	350TE	450TE
Min/Max (Amps)	40-210	50-240	55-270	55-330	40-400
Electrode Dia.	1.6-5mm	2.0-5mm	1.6-6mm	1.6-6mm	1.6-6mm
Open Circuit Volts	48	52	52	52	52
Volts/Phase	230/400V, 1ph	230/400V, 1ph	230/400V, 1ph	230/400V, 1ph	230/400V, 1ph
Max Input kW	5.0	6.5	7.0	10	17
Dimensions (mm)	440x280x320	360x310x600	800x400x500	800x400x500	1000x520x600
Weight (kg)	29	47	68	61	88
Part No.	6010235	6010780	6011000	6011010	6011020



Contents

Parts Lists & Diagrams		Page No.
Ideal for light fabrication work..body repairs and the like	105N	4-5
	115N	6-7
	160N	8-9
	190N	10-11
Professional welders with high efficiency turbo fans for tough daily use in automotive and maintenance workshops	145TN	12-13
	165TN	14-15
	190TE	16-17
As above with dual 230/110V input, ideal for the hire trade for use on building sites, shop fitting etc.	145ED	18-19
Professional welders for general fabrication work in workshops and manufacturing.	235TE	20-21
	260TE	22-23
	300TE	24-25
	350TE	26-27
	450TE	28-29
Wiring Diagrams		
	150N - 115N	30
	160N- 190N	31
	145TE- 165TE	32
	190TE - 145ED	33
	235TE - 260TE	34
	300TE - 350TE	35
	450TE	36

EASI ARC 105N

No.	Description	Qty	Part No.
01	Welding Current Switch 16A 250V	1	EM22200006
02	Yellow Pilot-light Switch 16A 250V	1	EM22200022
03	Rear Panel	1	EM33700160
04	Welding Cable 6mm ² Mt.2,4	1	EM43205075
05	Thermostat 16A	1	EM22210016
06	Transformer 230V 40x60	1	EM44110264
07	Handle	1	EM21600036
08	Upper Panel	1	EM33705290
09	Input Cable 2,5M 13A Fuse	1	EM20220068
10	Electrode Holder Clamp	1	EM22110029
11	Earth Cable 6mm ² 1,6M	1	EM43210001
12	Earth Clamp 120A	1	EM22110005
13	Plastic Mask 82x108 w/Handle	1	EM21905018
14	Transparent Glass 82x108	1	EM21905020
15	Dark Glass 82x108	1	EM21905021
16	Hammer/Brush	1	EM21905039
17	Cable Clamp	3	EM04600233

EASI ARC 105N

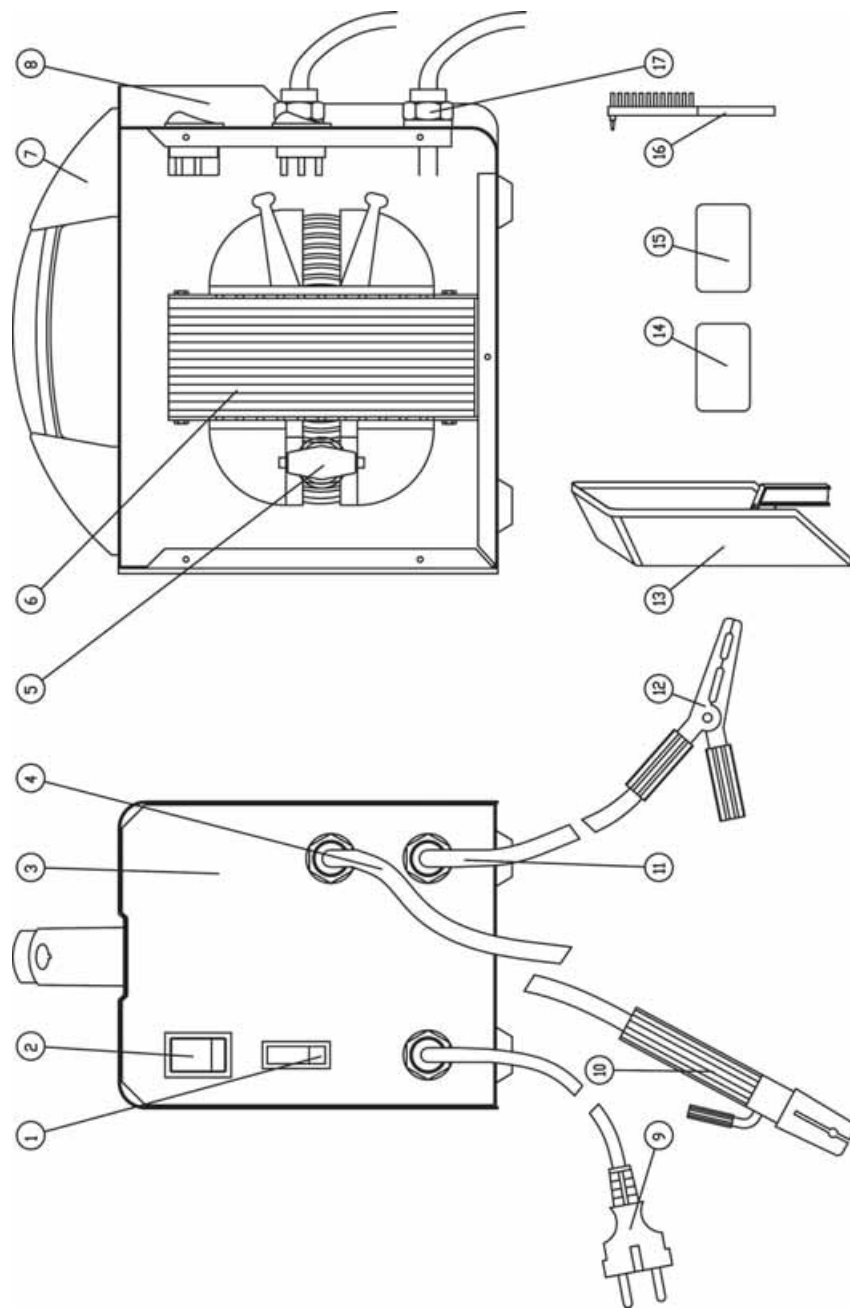

EASI ARC 115N

No.	Description	Qty	Part No.
01	Upper Panel	1	EM33705419
02	Yellow Pilot-light Switch 16A	1	EM22200022
03	Cable Clamp	3	EM04600233
04	Bent Handle	1	EM21600035
05	Transformer 230V	1	EM44110265
06	"C" Type Spring For Shunt	2	EM33800029
07	Indicator X Shunt	1	EM21690328
08	3 Lobe D.80 Hand-wheel	1	EM21800056
09	Input Cable 2,5M 13A fuse	1	EM20220068
10	Earth Cable 6 mm ² 1,6M	1	EM43210001
11	Earth Clamp 120A	1	EM22110005
12	Welding Cable 6mm ² 2.4M	1	EM43205075
13	Electrode Holder Clamp	1	EM22110029
14	Thermostat 16A	1	EM22210016
15	Lower Panel Shunt	1	EM33700232
16	Spring For Regulating Screw	1	EM33800028
17	Shunt	2	EM41415018
18	Shunt Yoke	1	EM33815010
19	Plastic Mask 82x108 W/Handle	1	EM21905018
20	Transparent Glass 82x108	1	EM21905020
21	Dark Glass 82x108	1	EM21905021
22	Hammer/Brush	1	EM21905039

EASI ARC 115N

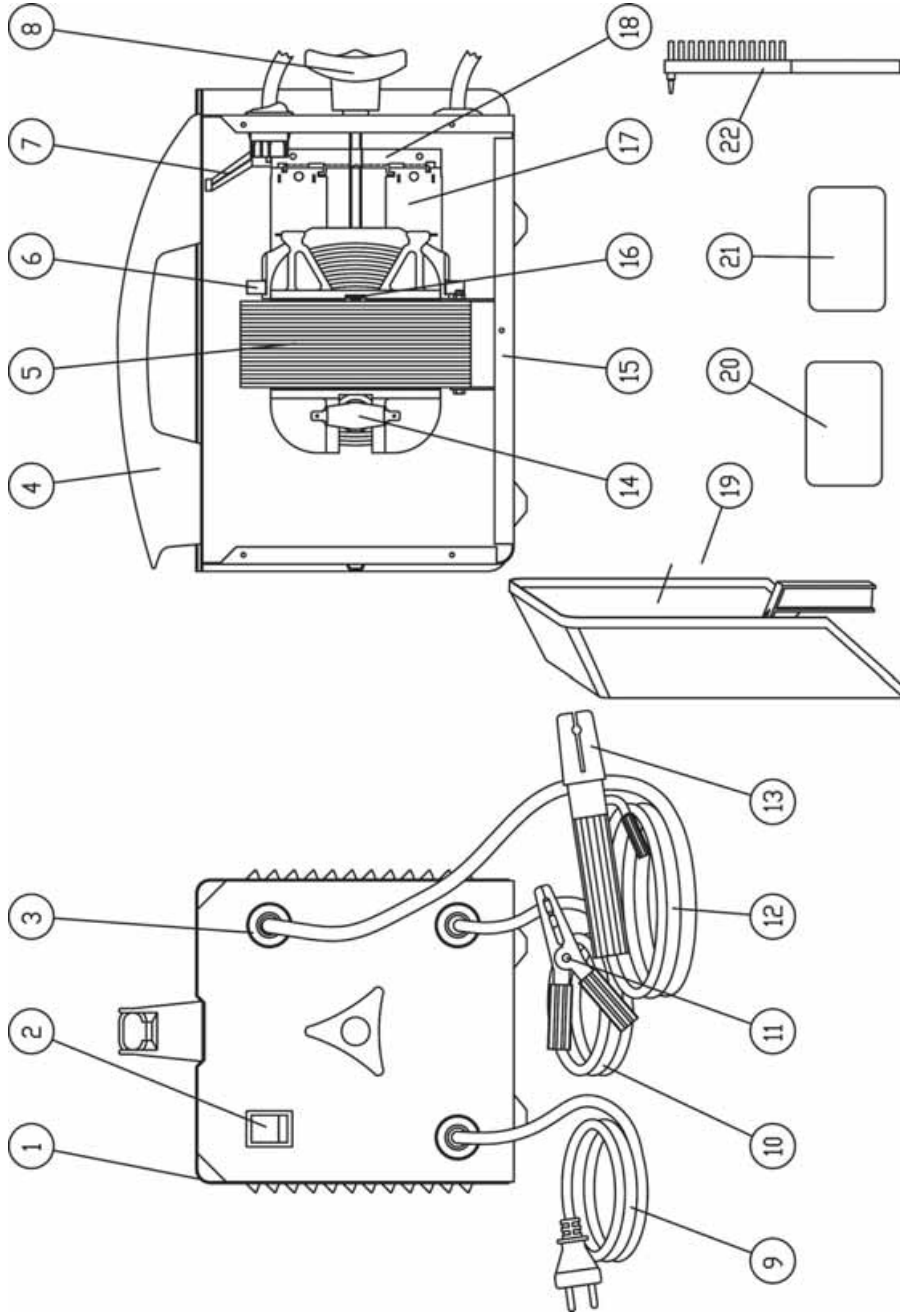

EASI ARC 160N

No.	Description	Qty	Part No.
01	Upper Panel	1	EM33705419
02	Yellow Pilot-light Switch 16A 250V	1	EM22200022
03	Cable Clamp	3	EM04600233
04	Handle	1	EM21600035
05	Transformer 230v 40x75	1	EM44110266
06	C" Type Spring For Shunt	2	EM33800029
07	Indicator Shunt	1	EM21690328
08	3 Lobe Hand-wheel	1	EM21800056
09	Input Cable 3x1,5 2,5 M	1	EM20220014
10	Earth Cable	1	EM43210021
11	Earth Clamp 120A	1	EM22110005
12	Welding Cable	1	EM43205069
13	Electrode Holder Clamp	1	EM22110029
14	Thermostat 16A	1	EM22210016
15	Lower Panel	1	EM33700232
16	Spring For Regulating Screw	1	EM33800028
17	Shunt 39x 93	2	EM41415018
18	Shunt Yoke	1	EM33815010
19	Plastic Mask 82x108 W/Handle	1	EM21905018
20	Transparent Glass 82x108	1	EM21905020
21	Dark Glass 82x108	1	EM21905021
22	Hammer/Brush	1	EM21905039

EASI ARC 160N

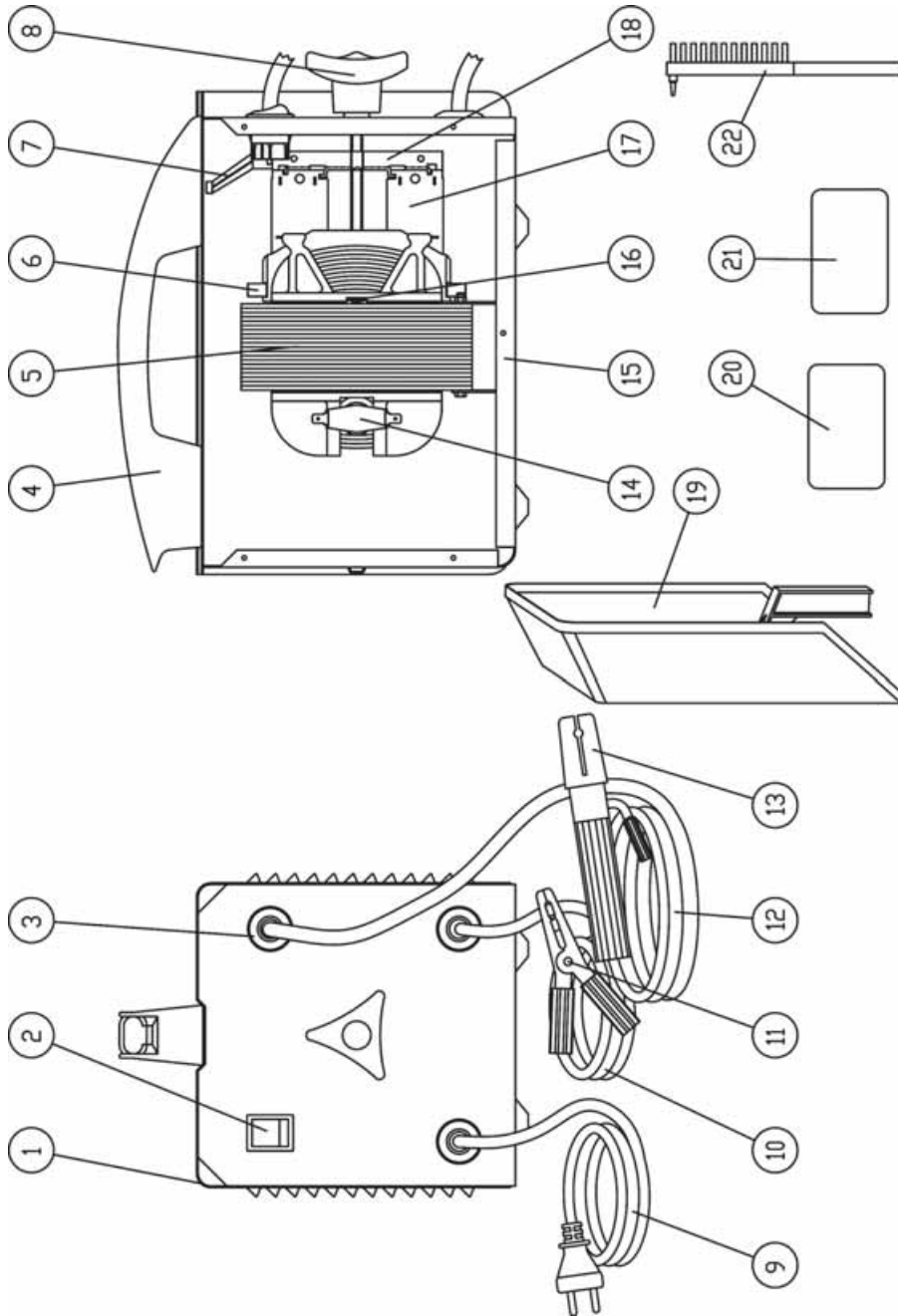

EASI ARC 190N

No.	Description	Qty	Part No.
01	Orange Pilot-lamp	1	EM 22610021
02	Switch Knob D.38	1	EM 21690179
03	Handle	1	EM 21600035
04	Upper Panel	1	EM 33705419
05	Thermostat 16A	1	EM 22210016
06	Spring For Regulating Screw	1	EM 33800028
07	"C Type Spring For Shunt	2	EM 33800029
08	Indicator Shunt	1	EM 21690328
09	Switch 12A On/Off	1	EM 22205009
10	Input Cable 3x2.5 2.5M	1	EM 20220020
11	Cable Clamp W/Self Tapping Screw	1	EM 04600234
12	Complete Black Connector	2	EM 04600022
13	Lower Panel Shunt	1	EM 33700232
14	Transformer 230v	1	EM44110268
15	Shunt	2	EM41415019
16	Shunt Yoke	1	EM33815010
17	3 Lobe Hand-wheel	1	EM 21800057
18	Earth Cable 16mm ² 2M	1	EM 43210136
19	Earth Clamp	1	EM22110007
20	Welding Cable 16mm ² 3M	1	EM 43205029
21	Electrode Holder	1	EM 22110011
22	Plastic Mask 82x108 W/handle	1	EM 21905018
23	Transparent Glass 82x108	1	EM 21905020
24	Dark Glass 82x108	1	EM 21905021
25	Hammer/Brush	1	EM 21905039

EASI ARC 190N

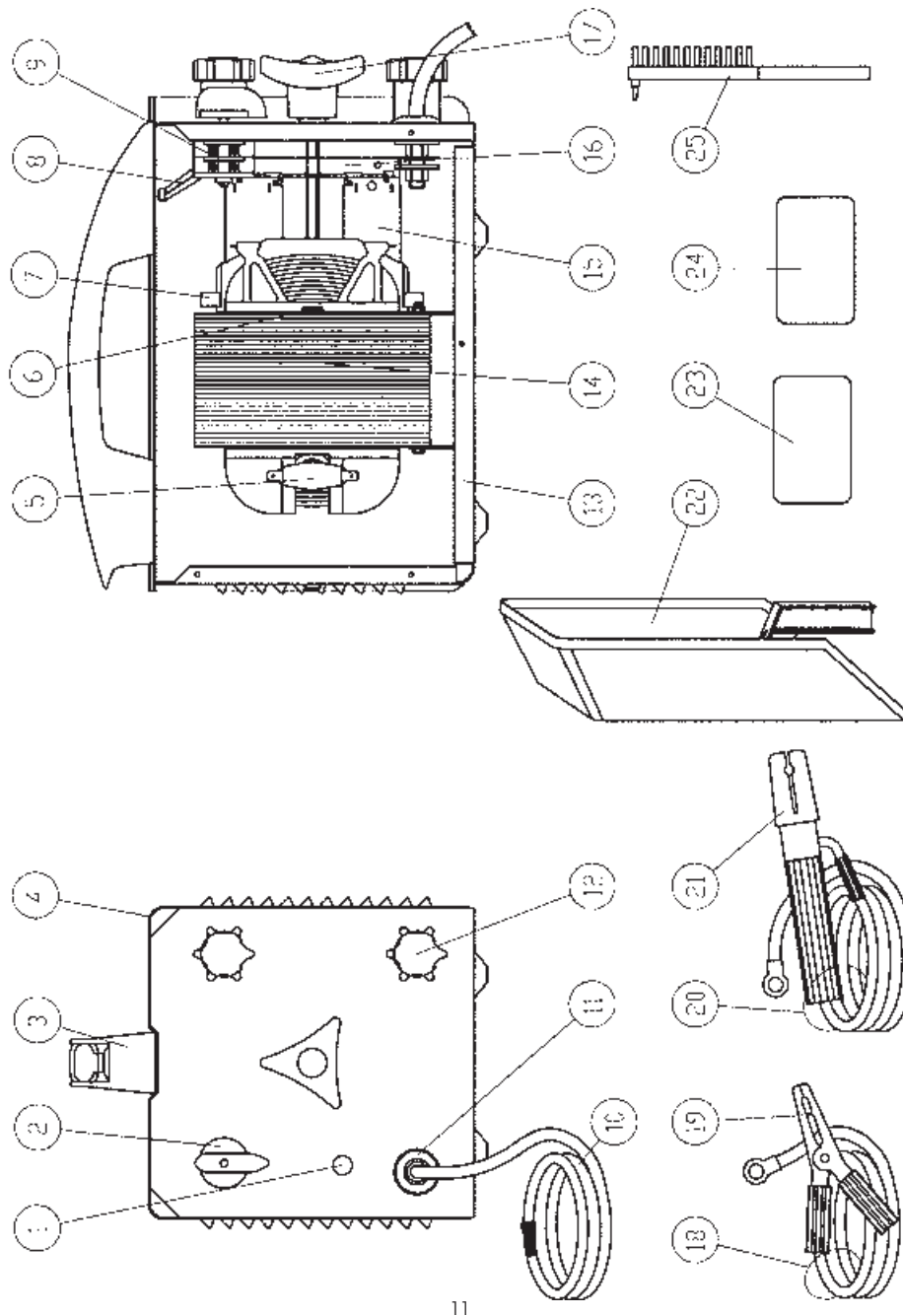

145TN

No.	Description	Qty	Part No.
01	Yellow Pilot-light Switch	1	EM22200022
02	Front Panel	1	EM33710059
03	Handle	1	EM21600035
04	Cover Panel	1	EM33705394
05	Complete Fan	1	EM04600055
06	Thermostat 16A	1	EM22210016
07	Transformer 230v 40x75	1	EM44110266
08	Spring For Shunt	2	EM33800029
09	Spring For Regulation Screw	1	EM33800028
10	Indicator X Shunt	1	EM21690384
11	Earth Cable 10mm ²	1	EM43210021
12	Earth Clamp 120A	1	EM22110005
13	Welding cable 10mm ² 2,4m	1	EM43205069
14	Electrode Holder	1	EM22110029
15	Input Cable 3x1,5 M 2,5	1	EM20220014
16	Cable Clamp Screw	3	EM04600233
17	Panel	1	EM33700033
18	Shunt	2	EM41415018
19	Shunt Yoke	1	EM33815010
20	3 Lobed Hand-wheel	1	EM21800056
21	Plastic Mask W/Handle	1	EM21905018
22	Transparent Glass 82x108	1	EM21905020
23	Dark Glass 82x108	1	EM21905021
24	Hammer-brush Mini	1	EM21905039

145TN

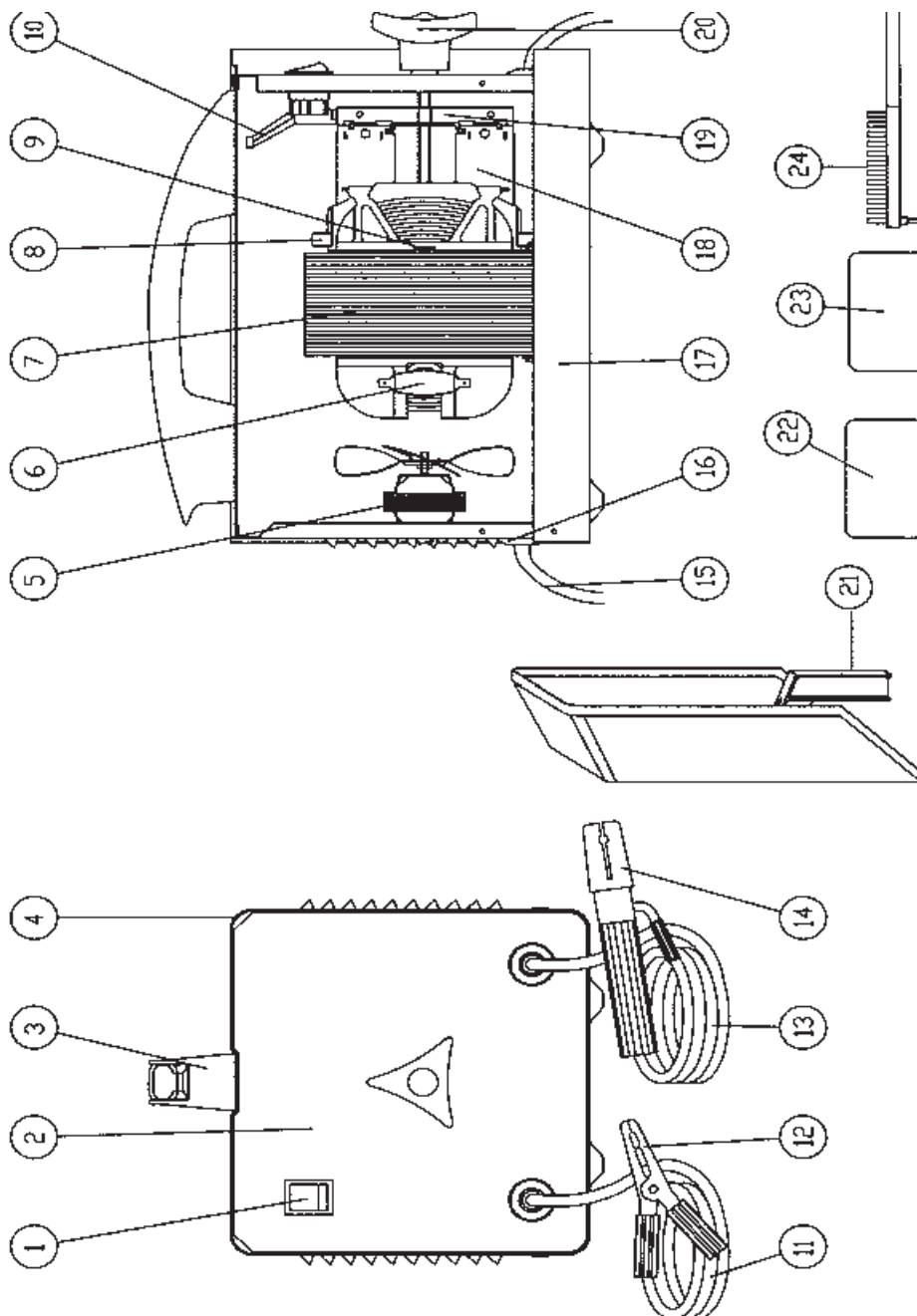

165TN

No.	Description		Part No.
01	Switch Knob D.34	7	EM21690015
02	Orange Pilot-lamp	1	EM22610012
03	Bent Handle	1	EM21600035
04	Cover Panel	1	EM33705393
05	Fan Kit 230V	1	EM04600056
06	Thermostat 16A	1	EM22210016
07	Transformer	2	EM44110269
08	"C" Type Spring For Shunt	2	EM33800029
09	Spring For Regulation Screw	1	EM33800028
10	Indicator Shunt	1	EM21690386
11	Connector	2	EM04600022
12	3 Lobed Hand-wheel	1	EM21800057
13	Front Panel	1	EM33710061
14	Input Cable 3x2,5 M.2,5	1	EM20220020
15	Cable Clamp + Screw	1	EM04600234
16	Lower Panel	1	EM33700035
17	Shunt 39x108	2	EM41415019
18	Shunt Yoke	1	EM33815010
19	Switch	1	EM22205026
20	Plastic Mask 82x108 W/handle	1	EM21905018
21	Transparent Glass 82x108	1	EM21905020
22	Dark Glass 82x108	1	EM21905021
23	Hammer-brush	1	EM21905011
24	Earth Clamp	1	EM22110007
25	Earth Cable 16mm ² 2M	1	EM43210136
26	Electrode Holder	1	EM22110011
27	Welding Cable 16mm ² 3M	1	EM43205029

165TN

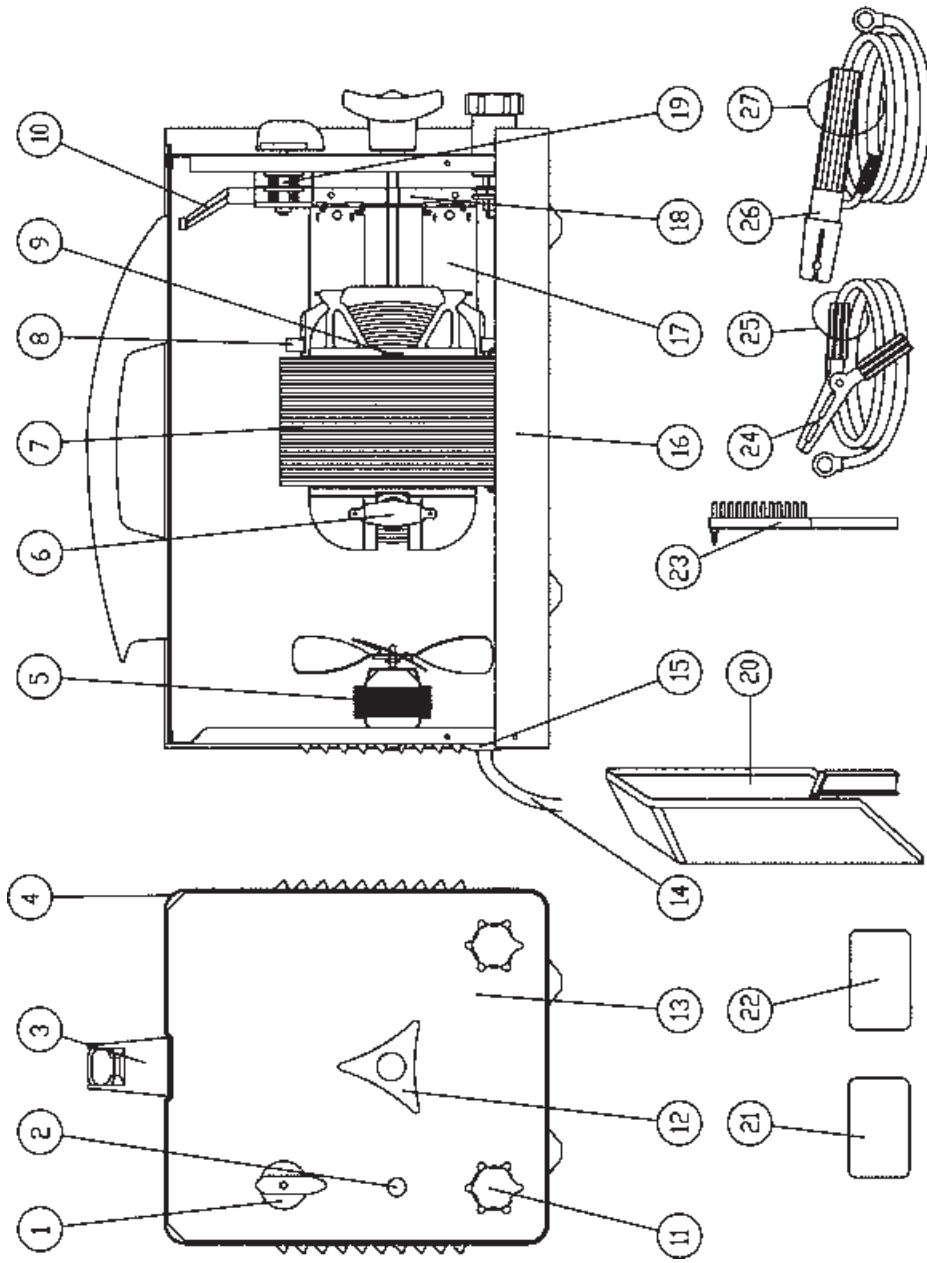

190TE

No.	Description	Part No.
01	Hand-wheel	EM21800015
02	Switch Knob	EM21690015
03	Switch	EM22205101
04	Shunt Yoke	EM33815002
05	Shunt	EM41415907
06	Handle	EM21600035
07	Transformer	EM44110011
08	Thermostat	EM22210016
09	Orange Pilot-lamp	EM22610012
10	Front Panel	EM33710061
11	Upper Panel	EM33705393
12	Hand-wheel	EM21800042
13	Transparent Glass	EM21905020
14	Insulating Washer	EM21615012
15	Dark Glass	EM21905021
16	Regulation Screw	EM33810032
17	Carton Mask	EM21905019
18	Hammer-brush	EM21905011
19	Fan Kit	EM04600056
20	Earth Clamp	EM22110007
21	Grommet	EM21605034
22	PVC Input Cable	EM20220020
23	Earth Cable	EM43210040
24	Electrode Holder	EM22110011
25	Lower Panel	EM33700035
26	Welding Cable	EM43205029

190TE

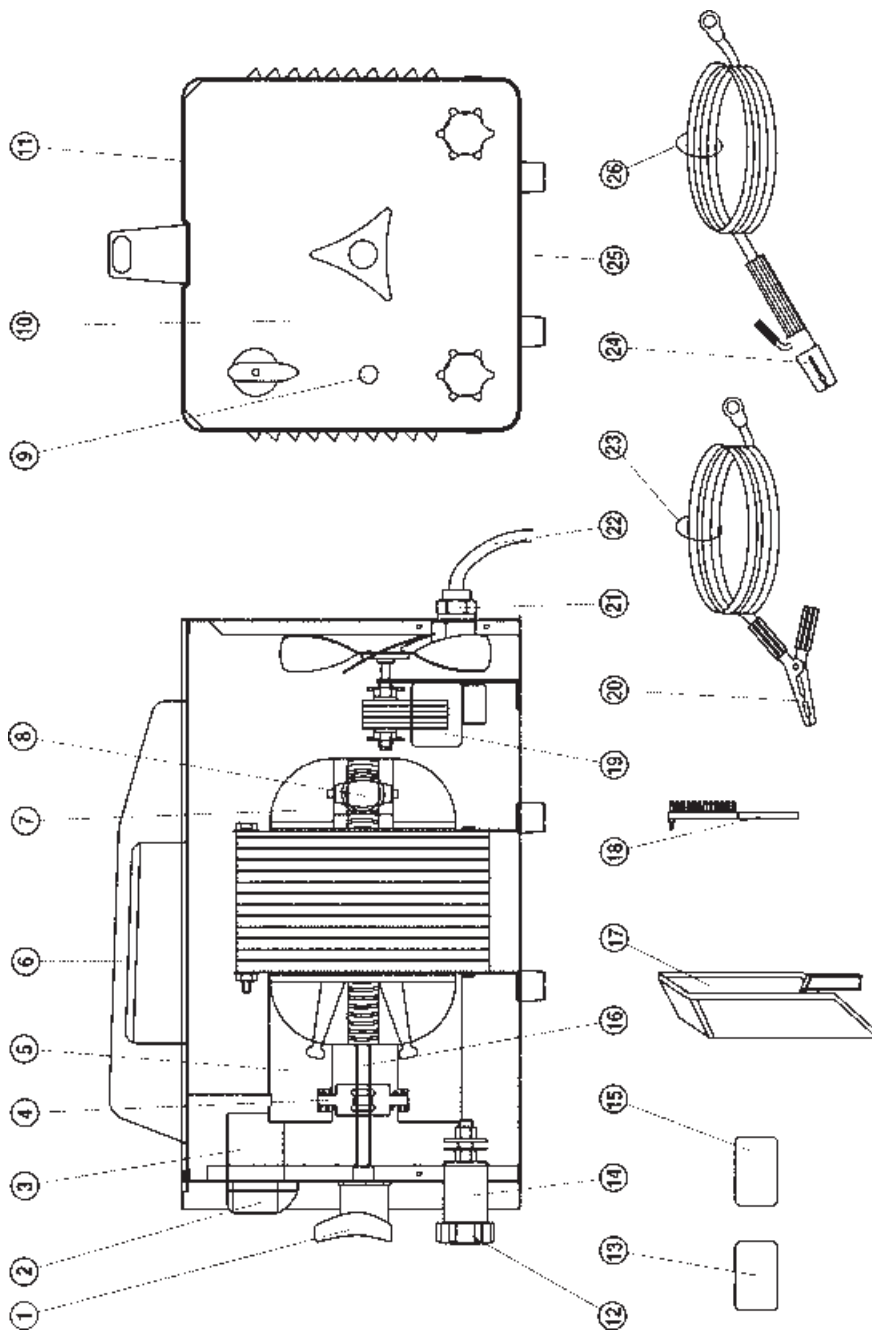

145ND

No.	Description		Part No.
01	Switch Knob	1	EM21690015
02	Orange Pilot-lamp	1	EM22610012
03	Handle	1	EM21600035
04	Front Panel	1	EM33710014
05	Cover Panel	1	EM33705394
06	PVC Input Cable M.2,5	1	EM20220020
07	Thermostat 25A	1	EM22210019
08	Spring For Regulation Screw	1	EM33800028
09	"C" Type Spring For Shunt	2	EM33800029
10	Indicator Shunt	1	EM21690384
11	Switch 17amp	1	EM22205101
12	Earth Cable 10mm ² M1.6	1	EM43210021
13	Earth Clamp	1	EM22110005
14	Welding Cable	1	EM43205069
15	Cable Clamp + Screw	2	EM04600233
16	Electrode Holder Clamp	1	EM22110029
17	Cable Clamp + Screw	1	EM04600234
18	Lower Panel	1	EM33700033
19	Transformer 110/230V	1	EM44110289
20	Shunt	2	EM41415018
21	Shunt Yoke	1	EM33815010
22	3 Lobe Hand-wheel	1	EM21800056
23	Plastic Mask W/handle	1	EM21905018
24	Transparent Glass 82x108	1	EM21905020
25	Dark Glass 82x108	1	EM21905021
26	Hammer/brush	1	EM21905039

145ND

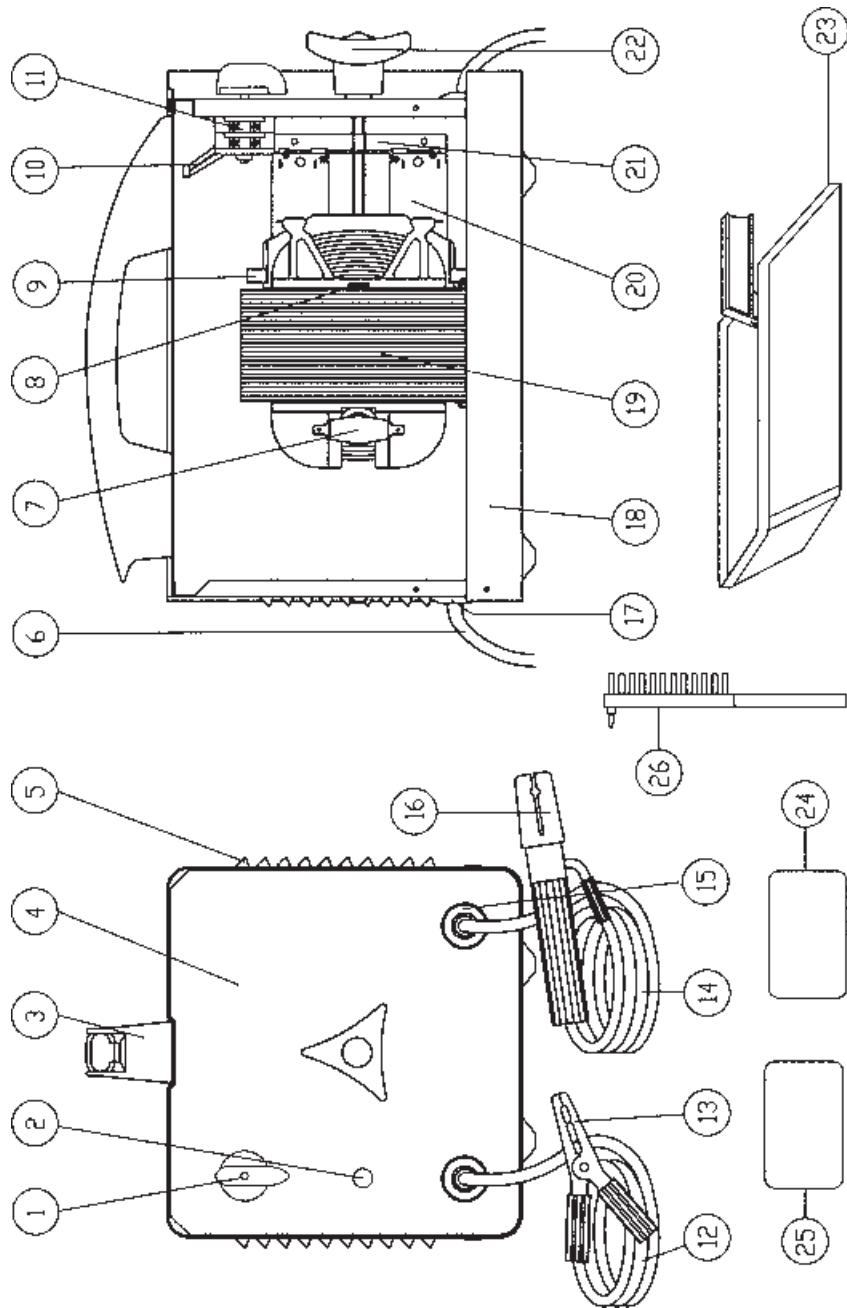

235TE

No.	Description	Part No.
01	Handle Extension Grip	EM21600006
02	Switch	EM22205101
03	Handle Extension	EM33725015
04	Handle	EM21600035
05	Transformer Shunt	EM44110015
06	Thermostat	EM22210019
07	Fan Kit	EM04600056
08	PVC Input Cable	EM20220022
09	Upper Panel	EM33705393
10	Switch Knob	EM21690015
11	Orange Pilot-lamp	EM22610012
12	Hand Wheel	EM21800015
13	Front Panel	EM33710061
14	Regulation Screw	EM33810032
15	Shunt Yolk	EM33815002
16	Magnetic Shunt	EM41415907
17	Lower Panel	EM33700035
18	Cable Clamp	EM21605034
19	Wheel Axle	EM55200037
20	Wheel	EM21605034
21	Plastic Foot Left	EM21610022
22	Connector Complete	EM04600022
23	Plastic Foot Right	EM21610021
24	Carton Mask	EM21905019
25	Transparent Glass	EM21905020
26	Dark Glass	EM21905021
27	Hammer Brush	EM21905011
28	Earth Clamp	EM22110007
29	Earth Cable	EM43210040
30	Electrode Holder	EM22110010
31	Welding Cable	EM43205004

235TE

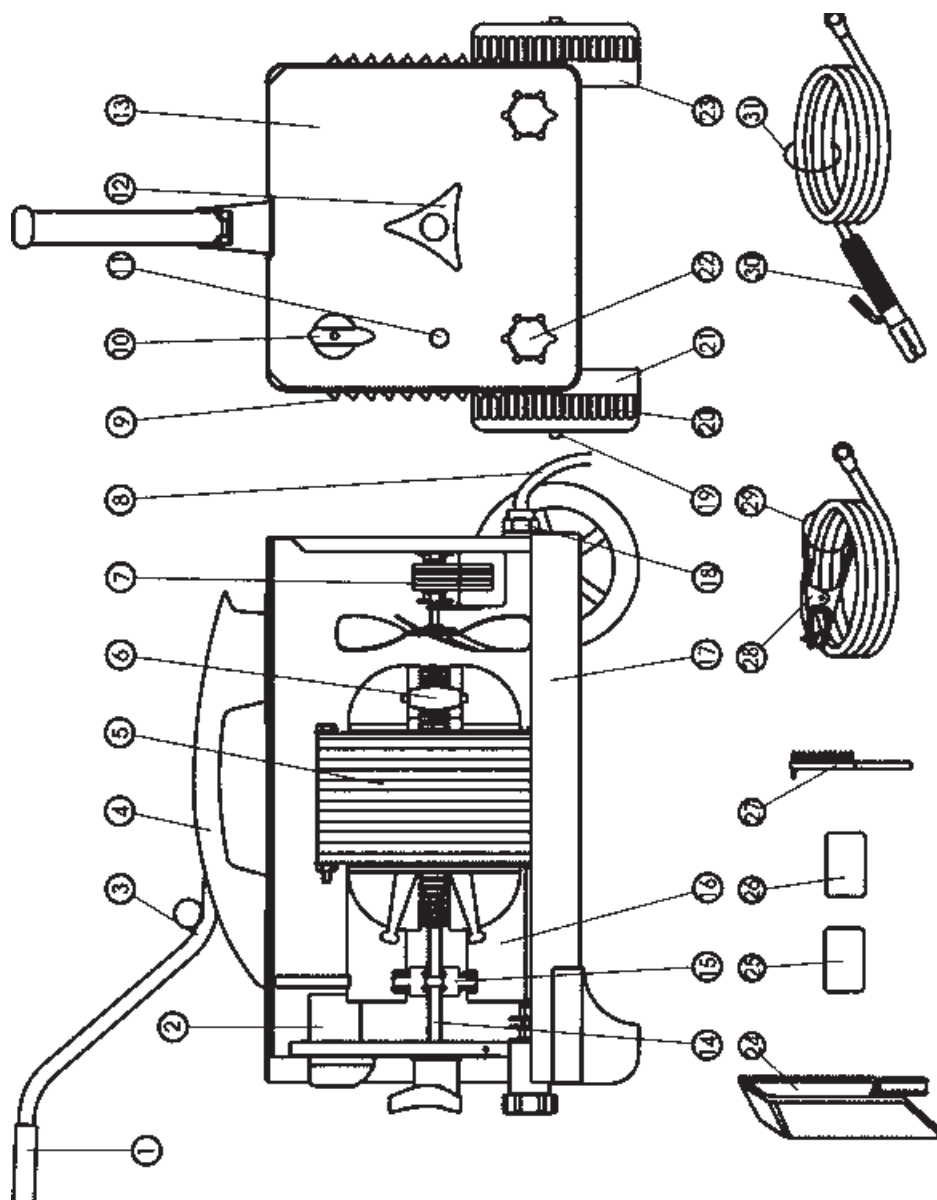

260TE

No.	Description	Part No.
01	Switch	EM22205045
02	Shunt Yoke	EM33815006
03	Shunt	EM41415906
04	Transformer	EM44110041
05	Handle	EM33725005
06	Secondary Winding	EM44010099
07	Primary Winding	EM44010098
08	Switch Knob	EM21690015
09	Front Panel	EM33710025
10	Hand-wheel W/Handle	EM21800017
11	Upper Panel	EM33705022
12	Back Panel	EM33715007
13	Orange Pilot-lamp	EM22610012
14	Cable Clamp	EM21605010
15	Insulating Washer	EM21615012
16	Transformer Holder	EM33640010
17	Regulation Screw	EM33810002
18	Thermostat	EM22210021
19	Fan	EM22800006
20	Input Cable	EM20220075
21	Wheels-axle	EM55200002
22	Wheel	EM21625007
23	Lower Panel	EM33700036
24	Foot	EM33740017
25	Hand-wheel	EM21800014
26	Carton Mask	EM21905019
27	Transparent Glass	EM21905020
28	Dark Glass	EM21905024
29	Hammer-brush	EM21905011
30	Earth Clamp	EM22110009
31	Earth Cable	EM43210012
32	Welding Cable	EM43205016
33	Electrode Holder	EM22110010

260TE

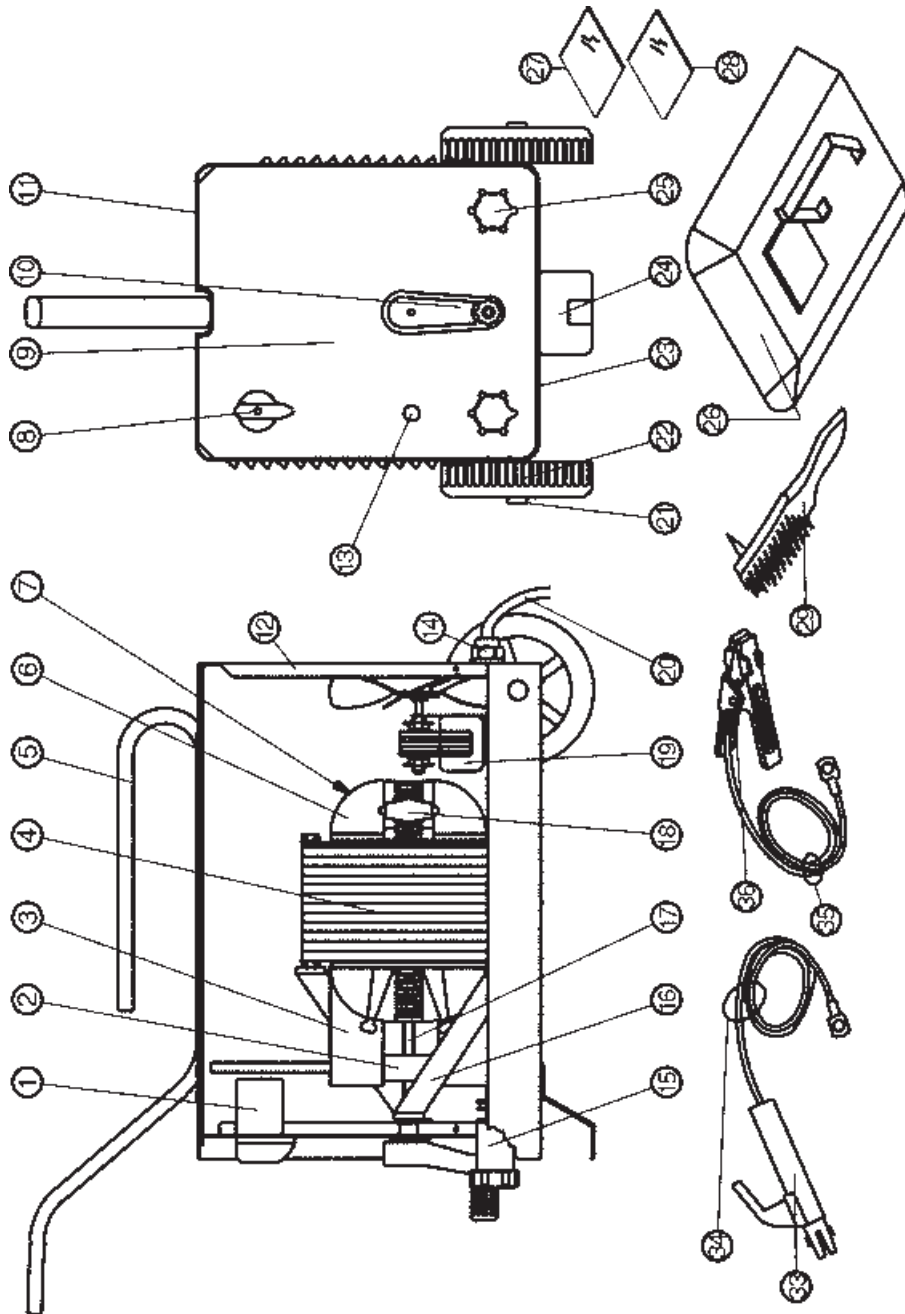

300TE

No.	Description	Qty	Part No.
01	Switch 25A Sch 5599	1	EM22205100
02	Shunt Yoke 0718 L=125	1	EM33815006
03	Shunt 28x44,5x190	2	EM41415906
04	Transformer 1Ph 230/400V	1	EM44110025
05	Secondary Winding70x1	1	EM44010045
06	Primary Winding 230/400V	1	EM44010044
07	Back Panel	1	EM33715074
08	Panel	1	EM33705483
09	Switch Knob	1	EM21690028
10	Handle	1	EM33725058
11	Green Pilot-lamp 220V	1	EM22610008
12	Hand Wheel Black+Knob	1	EM04600181
13	Transformer Holder	1	EM33640010
14	Regulation Screw	1	EM33810002
15	Panel	1	EM33700263
16	Fan 10W 230V	1	EM22800007
17	Cable Clamp Hole D.20	1	EM21605010
18	Input Cable	1	EM20220037
19	Wheels Axle D.20	1	EM 55200029
20	Wheel D.200	2	EM21625010
21	Dinse Socket 50sqmm	2	EM22100004
22	Front Panel	1	EM33710195
23	Face Mask 82x108	1	EM21905019
24	Transparent Glass 82x108	1	EM21905020
25	Dark Glass 82x108	1	EM21905024
26	Hammer-Brush	1	EM21905011
27	Earth Cable 25mm ² M.3	1	EM43210155
28	Earth Clamp 500A	1	EM22110026
29	Electrode Holder art202	1	EM22110010
30	Welding Cable 25 Sqmm M.5	1	EM43205015
31	Dinse Plug 50sqmm	2	EM22100003

300TE

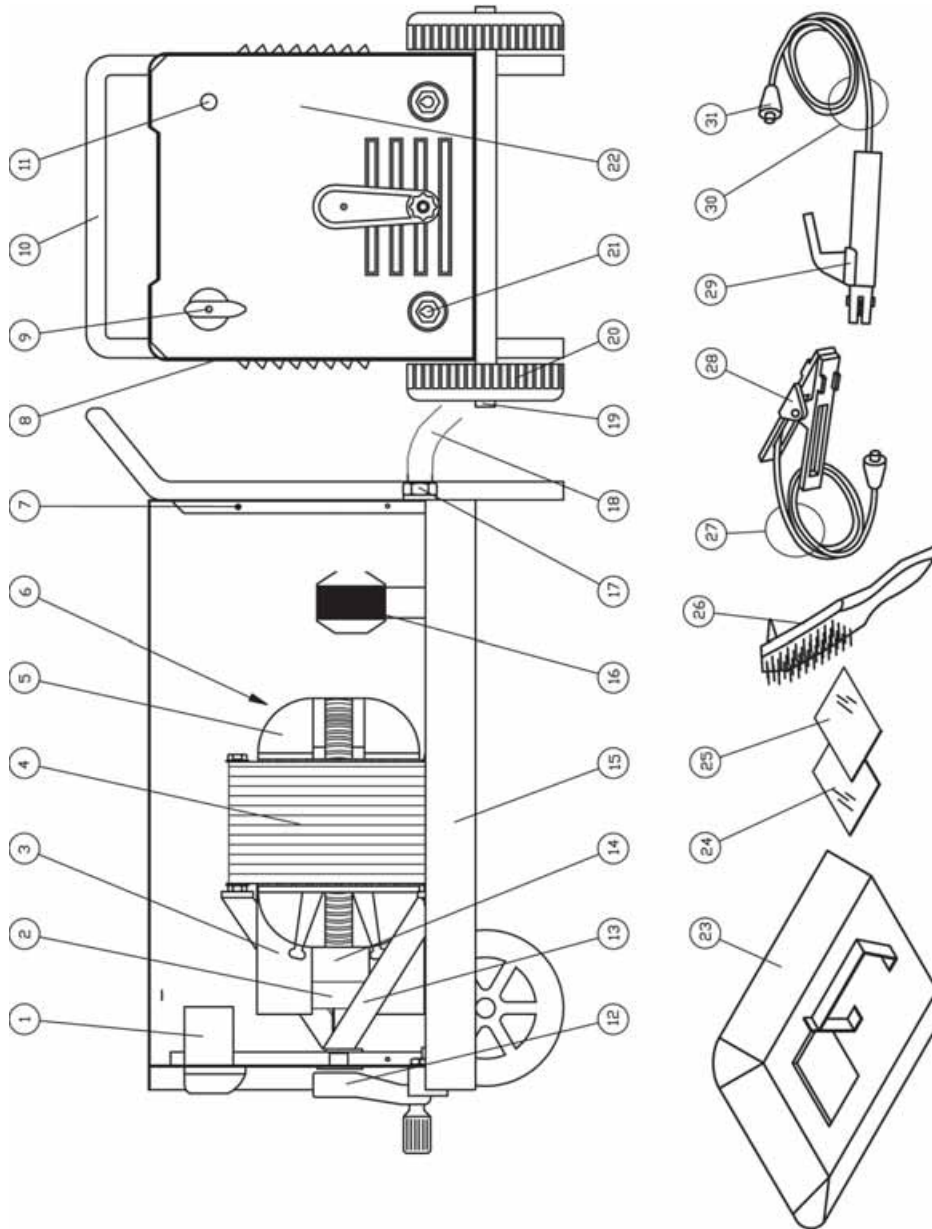

350TE

No.	Description	Qty	Part No.
01	Switch 25 A Sch 5599	1	EM22205100
02	Shunt Yoke 0.18	1	EM33815006
03	Shunt 28x44,5x190	2	EM41415906
04	Transformer 1Ph 230/400V	1	EM44110053
05	Secondary Winding	1	EM44010080
06	Primary Winding 230/400V	1	EM44010079
07	Back Panel	1	EM33715074
08	Panel	1	EM33705483
09	Switch Knob	1	EM21690028
10	Handle	1	EM33725058
11	Green Pilot-Lamp 220V	1	EM22610008
12	Hand Wheel Black+Knob	1	EM04600181
13	Transformer Holder	1	EM33640010
14	Regulation Screw 2x185 M8	1	EM33810002
15	Panel	1	EM33700263
16	Fan 10W 230V	1	EM22800007
17	Cable Clamp For Hole D.20	1	EM21605010
18	PVC Cable 3x6 M.4	1	EM20220129
19	Wheels Axle D.20	1	EM55200029
20	Wheel	2	EM21625010
21	Dinse Socket 50sqmm	3	EM22100004
22	Front Panel	1	EM33710195
23	Face Mask 82x108	1	EM21905019
24	Transparent Glass 82x108	1	EM21905020
25	Dark Glass 82x108	1	EM21905024
26	Hammer-Brush	1	EM21905011
27	Earth Cable 25Sqmm M.3	1	EM43210155
28	Dinse Plug 50sqmm	2	EM22100003
29	Earth Clamp 500A	1	EM22110026
30	Electrode Holder	1	EM22110010
31	Welding Cable 25 Sqmm M.5	1	EM43205015

350TE

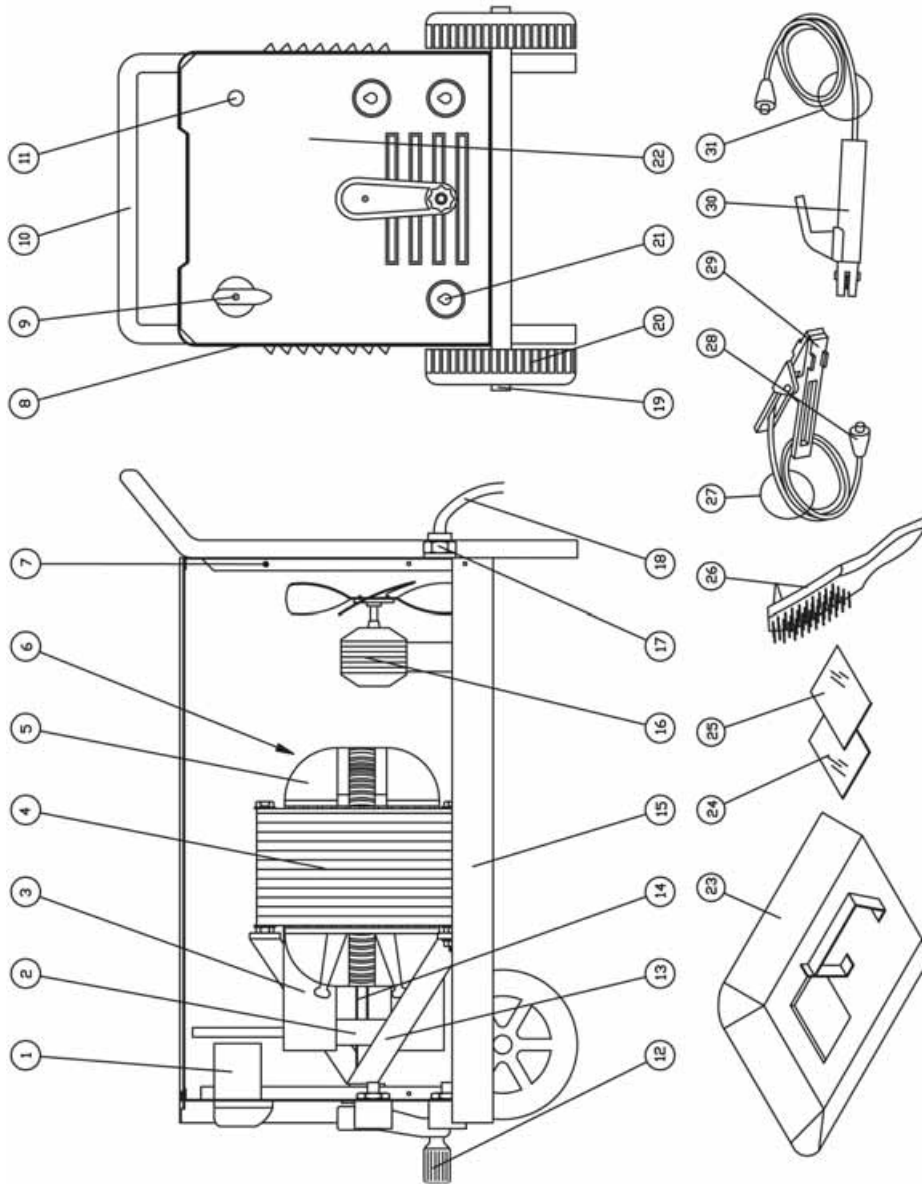

450TE

No.	Description		Part No.
01	PVC Input Cable 3x16 M4	1	EM20220101
02	Cable Clamp Hole D.30	1	EM21605011
03	Back Panel	1	EM33715033
04	Fan 25W 230V	1	EM22800009
05	Transformer 400V	1	EM44110177
06	Primary Winding 400V	2	EM44010302
07	Secondary Winding	2	EM44010290
08	Switch 63A	1	EM22205110
09	Switch Knob	1	EM21690016
10	Scale Holder	1	EM21690180
11	Regulation Index	1	EM21690255
12	Shunt Yoke	1	EM33815009
13	Regulation Screw M24	1	EM33810037
14	Hand-wheel W/Handle	1	EM21800018
15	Front Panel	1	EM33710196
16	Dinse Socket 50mm ²	3	EM22100004
17	Right Side Panel	1	EM33705350
17a	Left Side Panel	1	EM33705349
17b	Upper Panel	1	EM33705235
18	Shunt	1	EM41415908
19	Green Pilot-lamp 230V	1	EM22610015
20	Lamp Holder	1	EM22610018
21	Lower Panel	1	EM33700073
22	Wheel-axle	1	EM55200006
23	Rear Wheel	2	EM21625011
24	Caster	2	EM21625003
25	Handle	1	EM33725035
26	Lifting-eye	2	EM21070001
27	Carton Mask 82x108	1	EM21905019
28	Transparent Glass 82x108	1	EM21905020
29	Dark Glass 82x108	1	EM21905024
30	Hammer-brush	1	EM21905011
31	Earth Cable 50mm ² M3	1	EM43210110
32	Earth Clamp	1	EM22110014
33	Welding Cable 50mm ² .	1	EM43205037
34	Electrode Holder	1	EM22110016
35	Dinse Plug 50mm ²	2	EM22100003

450TE

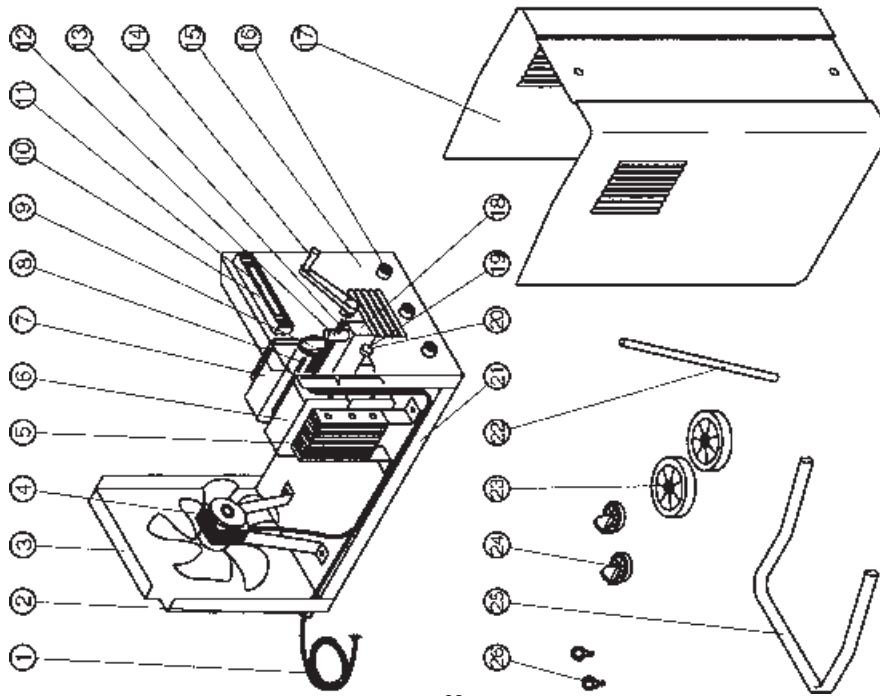
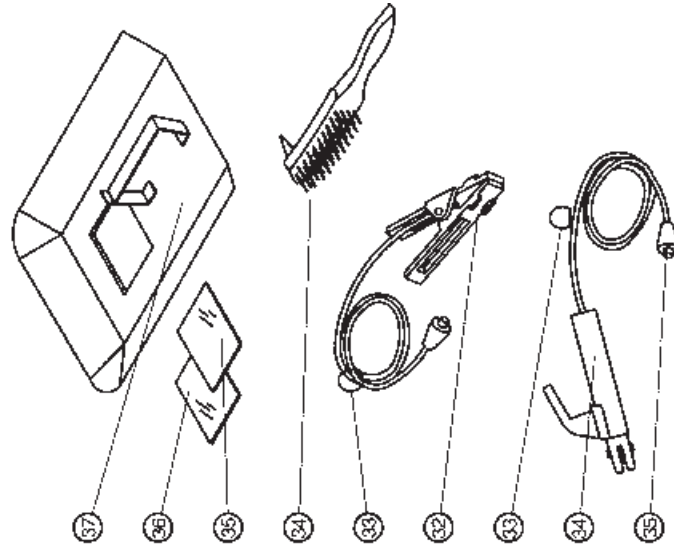

WIRING DIAGRAMS

105N

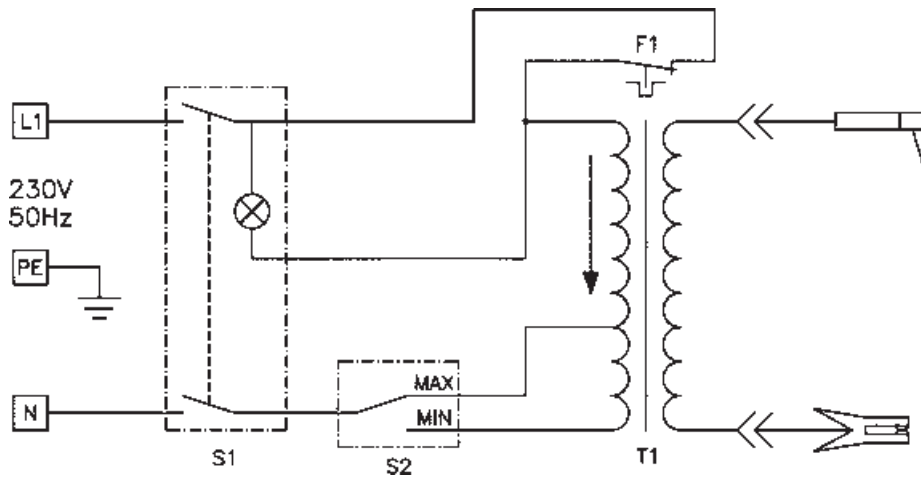

115N

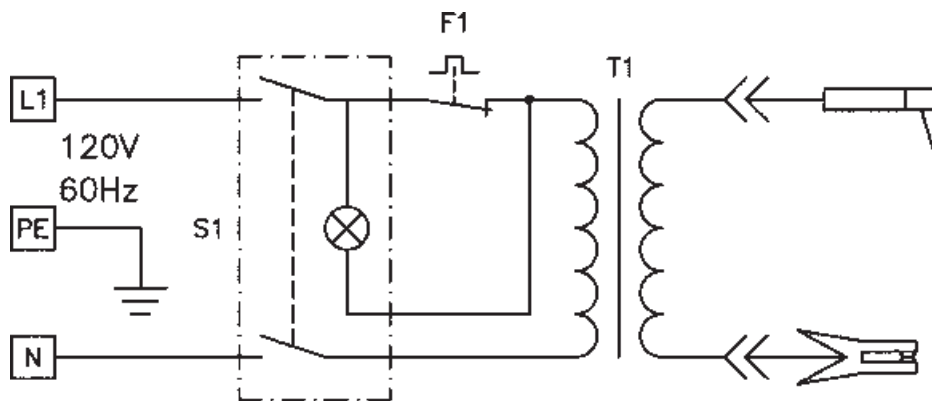

160N

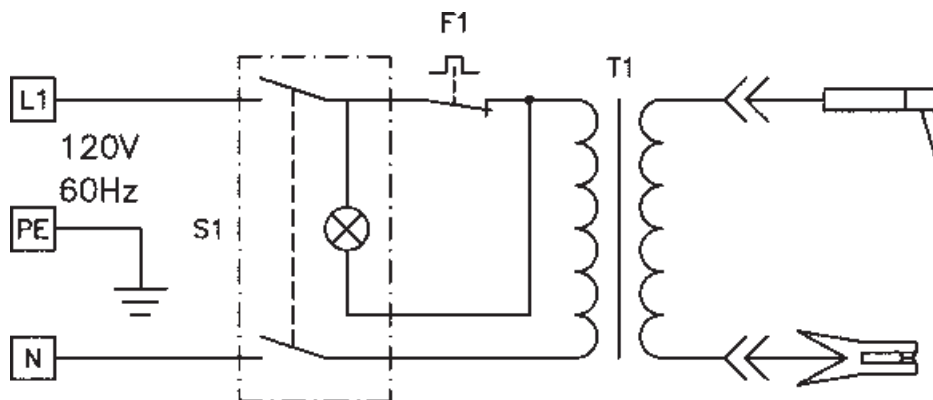

190N

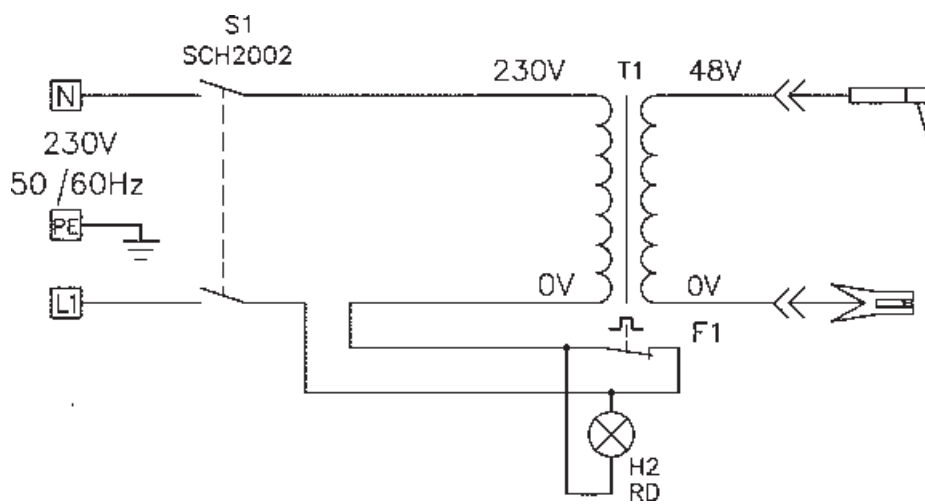

145TN

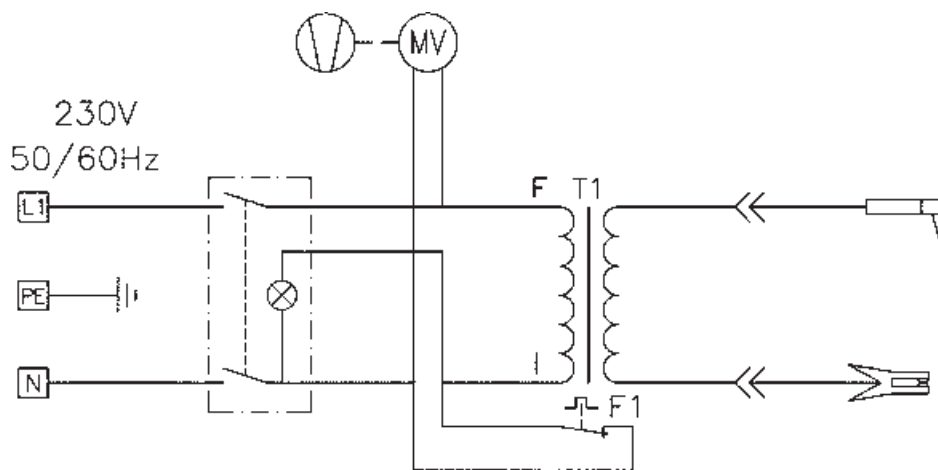

165TN

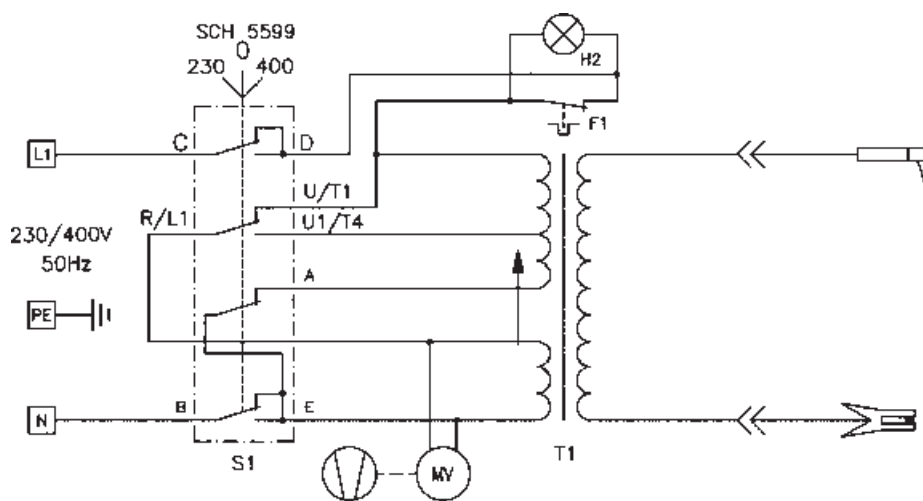

190TE

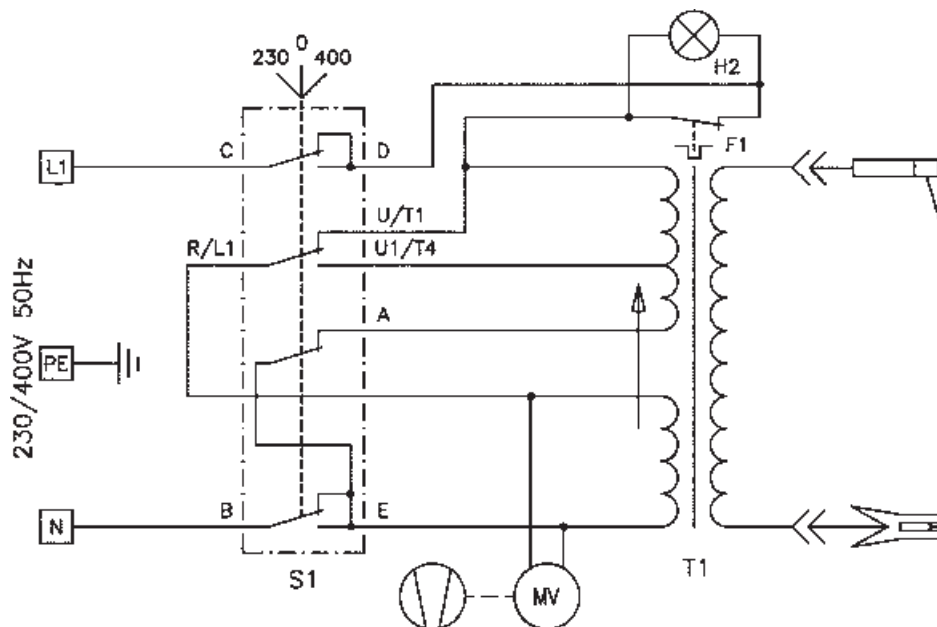

145ND

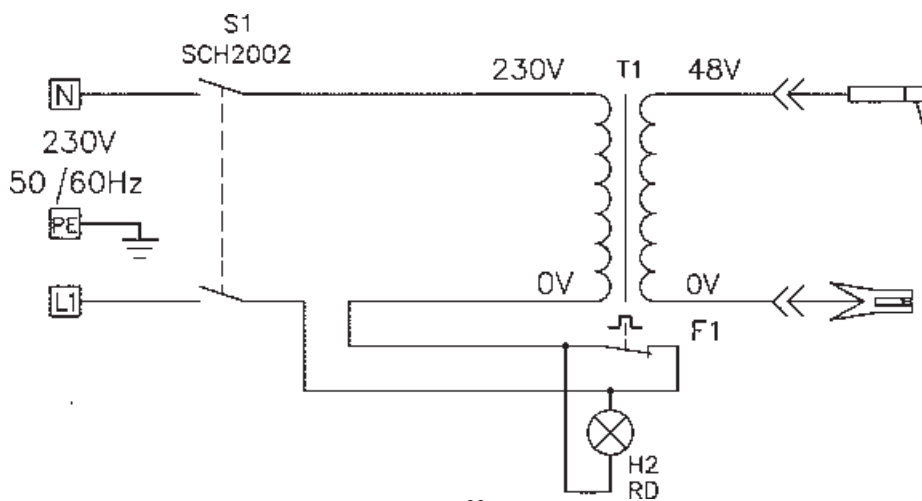

230TE

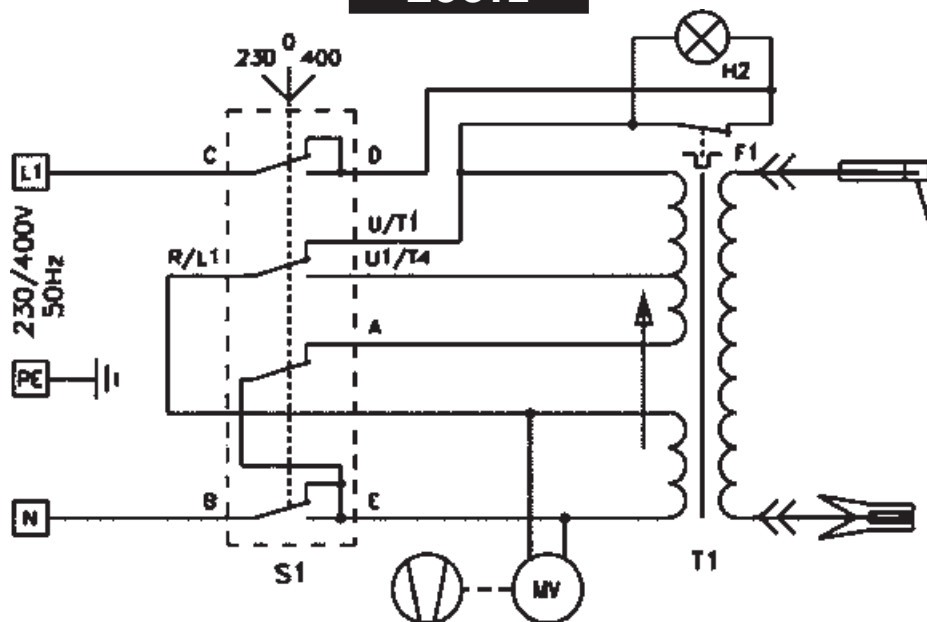

260TE

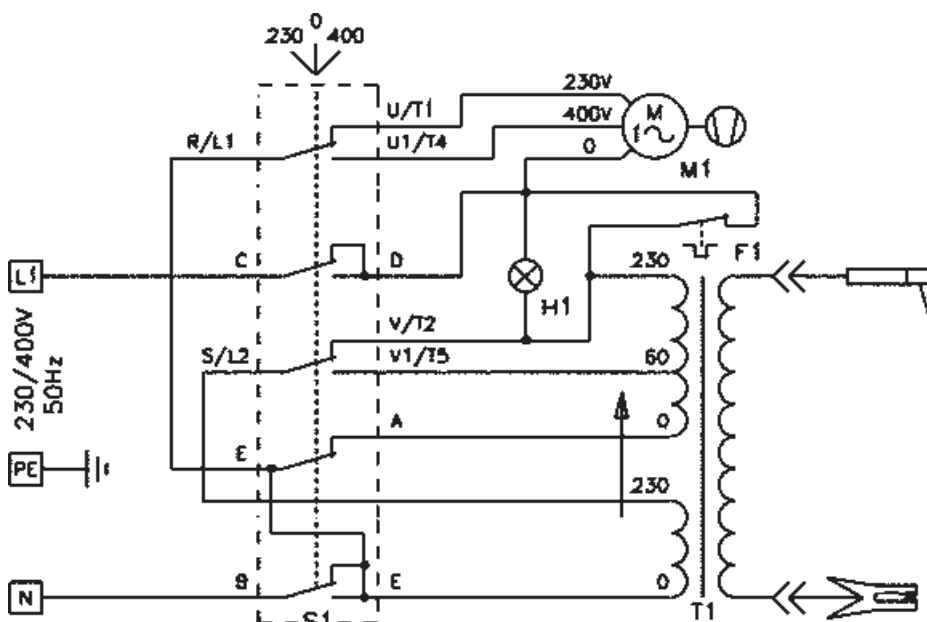

300TE

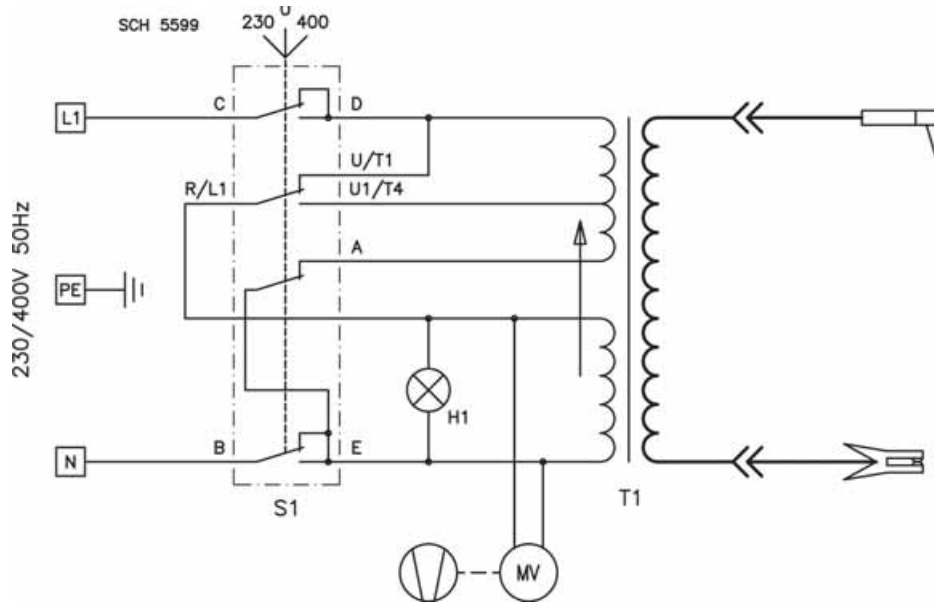

350TE

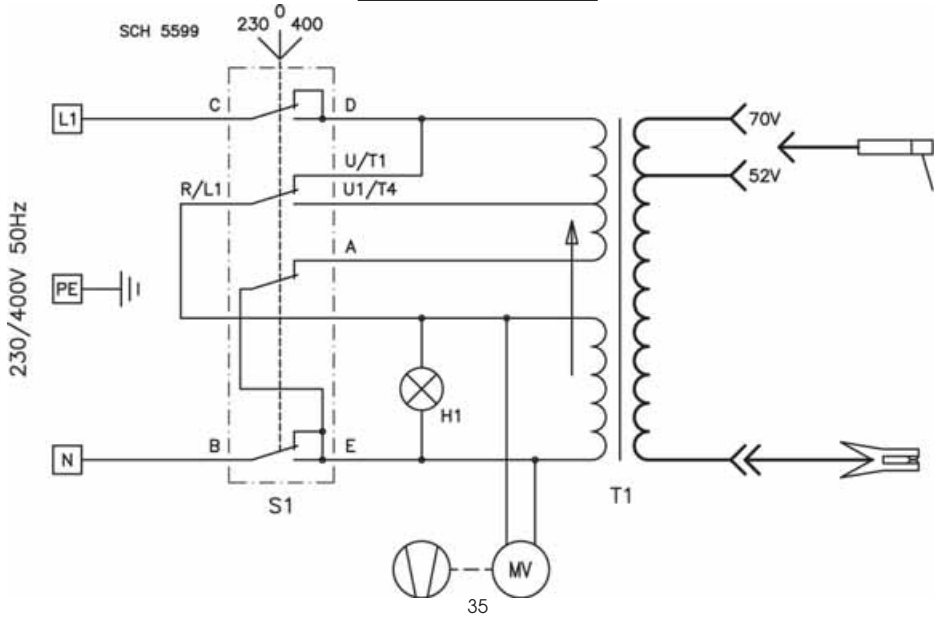

450TE

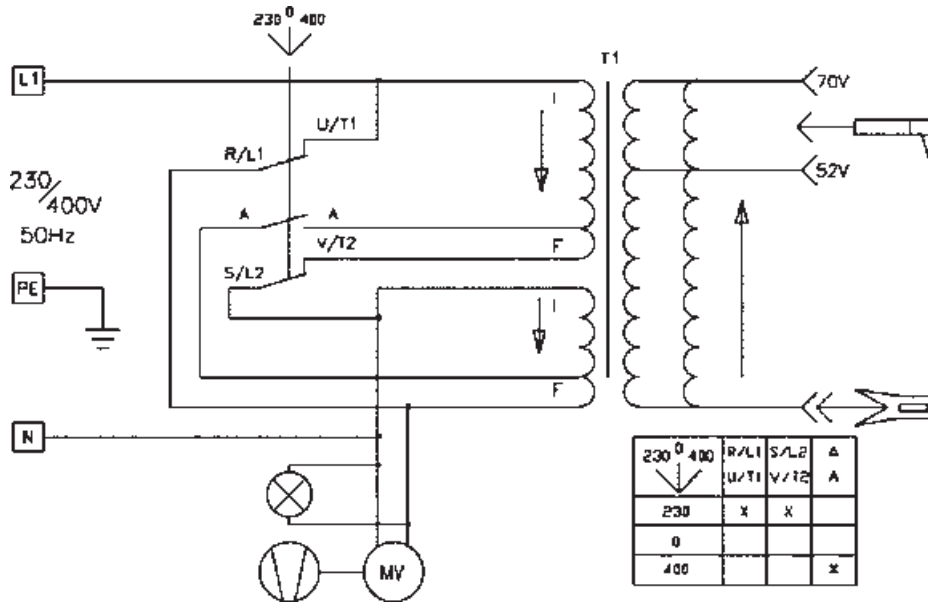

Parts & Service Contacts

For Spare Parts and Service, please contact your nearest dealer, or CLARKE International, on one of the following numbers.

PARTS & SERVICE TEL: 020 8988 7400

PARTS & SERVICE FAX: 020 8558 3622

or e-mail as follows:

PARTS: Parts@clarkeinternational.com

SERVICE: Service@clarkeinternational.com